

**TECHNICAL MANUAL**

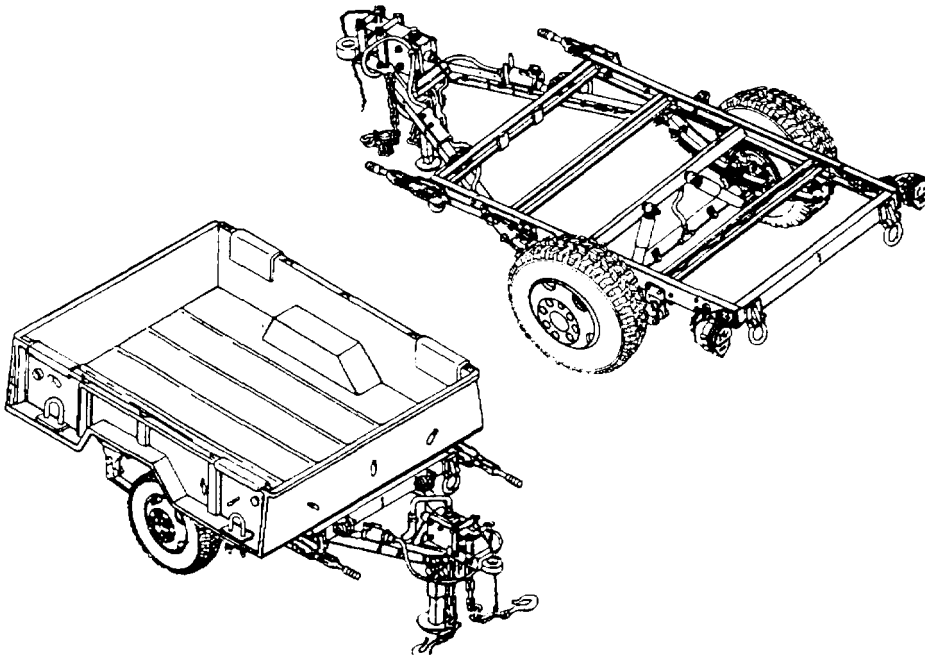
**OPERATOR'S, UNIT, DIRECT SUPPORT, AND  
GENERAL SUPPORT MAINTENANCE MANUAL (INCLUDING  
REPAIR PARTS AND SPECIAL TOOLS LIST)**

**FOR**

**TRAILER, CARGO, 3/4-TON, 2-WHEEL  
M101 A2 (2330-01-102-4697)  
M101 OIA3 (2330-01-372-5641)**

**TRAILER, CHASSIS, 3/4-TON, 2-WHEEL  
M116A2 (2330-01-101-8434)  
M116A2E1 (2330-01-333-9773)**

**TRAILER, CHASSIS, 1-TON, 2-WHEEL  
M116A3 (2330-01-359-0080)**



Approved for public release; distribution is unlimited.

<b>INTRODUCTION</b>	<b>1-1</b>
---------------------	------------

<b>OPERATING INSTRUCTIONS</b>	<b>2-1</b>
-----------------------------------	------------

<b>OPERATOR/CREW PMCS</b>	<b>2-3</b>
-------------------------------	------------

<b>OPERATOR/CREW TROUBLESHOOTING PROCEDURES</b>	<b>3-2</b>
---	------------

<b>UNIT PMCS</b>	<b>4-3</b>
----------------------	------------

<b>UNIT TROUBLESHOOTING PROCEDURES</b>	<b>4-7</b>
--	------------

<b>DIRECT SUPPORT AND GENERAL SUPPORT MAINTENANCE</b>	<b>5-1</b>
---	------------

<b>MAINTENANCE ALLOCATION CHART</b>	<b>B-1</b>
---	------------

<b>REPAIR PARTS AND SPECIAL TOOLS LIST</b>	<b>E-1</b>
--	------------

<b>LUBRICATION INSTRUCTIONS</b>	<b>I-1</b>
-------------------------------------	------------

<b>INDEX</b>	<b>INDEX-1</b>
--------------	----------------



FOR INFORMATION ON FIRST AID, REFER TO FM 21-11.

**WARNING**



**ASBESTOS**

DO NOT handle brakeshoes, brakedrums, or other brake components unless the area has been properly cleaned. Asbestos dust, which can be dangerous if you touch it or breathe it, may be on these components. Wear an approved filter mask and gloves. NEVER use compressed air or a dry brush to clean brake components. Dust may be removed using an industrial-type vacuum cleaner. Clean dust or mud away from brake components with water and a wet, soft brush or cloth. Failure to follow this warning may result in serious illness or death to personnel.

**WARNING**

**BRAKE SYSTEM**

- Do not allow grease to contact brakeshoe linings. Wipe excess lubricant from the area of brakeshoe linings to prevent grease from soaking the linings. Brakeshoe linings can absorb grease and oil, causing early glazing of linings and very poor braking action. If brakeshoe linings become soaked, Unit maintenance must replace them. Failure to follow this warning may cause brakes to malfunction, resulting in serious injury or death to personnel or damage to equipment.
- If a brakeshoe lining is replaced, replace all brakeshoe linings on axle. A combination of old brakeshoes with new brakeshoes will cause uneven braking. Accidents causing serious injury or death to personnel or damage to equipment may result.
- When performing maintenance on brake system, make sure wheels are chocked securely. Failure to follow this warning may cause trailer to roll, resulting in serious injury or death to personnel or damage to equipment.

**WARNING**

**COMPRESSED AIR**

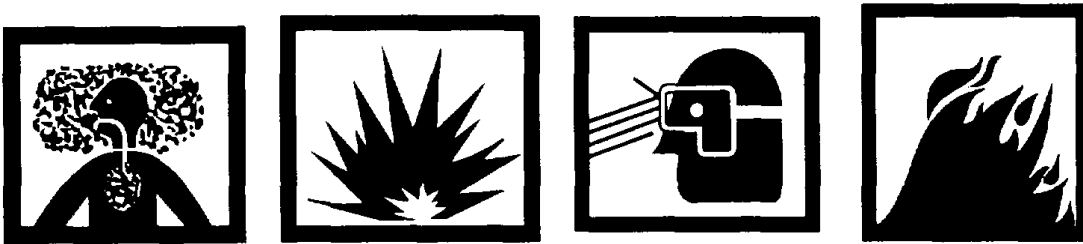
Compressed air used for cleaning or drying purposes, or for clearing restrictions, should never exceed 30 psi (207 kPa). Wear protective clothing (e.g., goggles/shield, gloves) and use caution, to avoid injury to personnel.

**WARNING****COUPLING AND UNCOUPLING**

- All personnel must stand clear of towing vehicle and trailer during coupling and uncoupling operations. Failure to follow this warning may result in serious injury or death to personnel.
- If trailer is not coupled to towing vehicle, make sure handbrakes are applied or wheels are securely chocked. Failure to follow this warning may cause trailer to roll, resulting in serious injury or death to personnel or damage to equipment.

**WARNING****DRAWBAR**

Drawbar is heavy (280 lb [127 kg] loaded tongue weight). Four or more persons are needed to lift drawbar. Failure to follow this warning may result in injury to personnel.

**WARNING****DRYCLEANING SOLVENT**

- Drycleaning solvent P-D-680 is TOXIC and flammable. Wear protective goggles and gloves; use only in a well-ventilated area; avoid contact with skin, eyes, and clothes; and DO NOT breathe vapors. Keep away from heat or flame. Never smoke when using drycleaning solvent; the flashpoint for type I drycleaning solvent is 100°F (38°C) and for type II it is 138°F (50°C). Failure to follow this warning may result in injury or death to personnel.
- If personnel become dizzy while using drycleaning solvent, immediately get fresh air and medical help. If solvent contacts skin or clothes, flush with cold water. If solvent contacts eyes, immediately flush them with water and get immediate medical attention.
- When drycleaning solvent is used, notify the local medical authority (preventive medicine) and environmental coordinator concerning medical surveillance, respiratory protection, and disposal requirements.

**WARNING****IMPROPER CLEANING AGENTS**

Improper cleaning methods and the use of unauthorized cleaning agents can injure personnel and damage equipment. To prevent this, refer to TM 9-247 for instructions.

**WARNING****STEAM**

Avoid contact with steam. Steam can cause burns, blindness, and other serious injuries. Be sure to wear protective apron, gloves, and safety goggles when using live steam.

**WARNING****RIVETS/DRIVE SCREWS**

Wear eye protection when driving heads off rivets or drive screws. Failure to follow this warning may result in eye injury or loss of vision.

**WARNING****HEAVY COMPONENTS**

Use extreme caution when handling heavy parts. A lifting device is required when parts weigh over 50 pounds (23 kg) for a single-person lift, over 100 pounds (45 kg) for a two-person lift, and over 150 pounds (68 kg) for a three-person or more lift. Keep clear of heavy parts supported only by lifting device. Failure to follow this warning may cause serious injury or death to personnel.

**WARNING****HOT COMPONENTS**

When checking for improperly adjusted brakes or dry wheel bearings, cautiously feel each wheel hub and brakedrum. Serious burns will result from touching an overheated wheel hub and brakedrum.

**WARNING****INTERVEHICULAR CABLE**

Make sure intervehicular cable is disconnected from towing vehicle before performing maintenance on electrical system. Failure to follow this warning may result in electric shock or burns.

**WARNING****REAR STABILIZER**

- Rear stabilizer must be used if trailer is carrying generator sets. Failure to follow this warning may cause trailer to tip, resulting in serious injury to personnel or damage to equipment.
- Make sure weight of trailer is on front support leg before raising rear stabilizer. Failure to follow this warning may cause trailer to tip, resulting in serious injury to personnel or damage to equipment.

**WARNING****TAILGATE (CARGO TRAILER)**

Hold tailgate in place before removing straight-headed pins. If tailgate is not properly supported it may fall, resulting in injury to personnel.

**WARNING****TIRES**

- **DO NOT** break tire bead and split lockring until certain that no air pressure remains in tire. Failure to follow this warning may cause lockring to fly off, resulting in serious injury or death to personnel.
- An improperly seated lockring may fly off, resulting in serious injury or death to any person in its path. A bent or twisted lockring may be difficult to install and, if used, is a safety hazard. Before applying any air pressure to tire, make sure lockring is seated against rim of wheel in its entirety. **DO NOT** inflate more than 3 psi (21 kPa). Tap lockring carefully with a mallet to check its seating.
- Inflate tire in an inflation safety cage using an extension hose of a least 10 feet (3 m) with an on/off pressure control valve and pressure gage. **DO NOT** stand on lockring side of wheel and tire assembly. Failure to follow this warning may result in severe injury or death to personnel.

TECHNICAL MANUAL  
NO. 9-2330-202-14&P

HEADQUARTERS  
DEPARTMENT OF THE ARMY  
Washington, D.C., 28 May 1999

**OPERATOR'S, UNIT, DIRECT SUPPORT, AND GENERAL SUPPORT  
MAINTENANCE MANUAL (INCLUDING REPAIR PARTS  
AND SPECIAL TOOLS LIST)  
FOR**

**TRAILER, CARGO, 3/4-TON, 2-WHEEL  
M101A2 (2330-01-102-4697)  
M101A3 (2330-01-372-5641)**

**TRAILER, CHASSIS, 3/4-TON, 2-WHEEL  
M116A2 (2330-01-101-8434)  
M116A2E1 (2330-01-333-9773)**

**TRAILER, CHASSIS, 1-TON, 2-WHEEL  
M116A3 (2330-01-359-0080)**

TM 9-2330-202-14&P, 12 May 1997, is changed as follows:

1. Remove old pages and insert new pages.
2. New or changed material is indicated by a vertical bar in the margin of the page.

**Remove Pages**

4-101 and 4-102  
4-119 and 4-120  
B-5 and B-6  
16-1 through Figure 18  
23-1 through BULK-1  
I-1 through I-10

**Insert Pages**

4-101 and 4-102  
4-119 and 4-120  
B-5 and B-6  
16-1 through Figure 18  
23-1 through BULK-1  
I-1 through I-10


3. File this change sheet in front of the publication for reference purpose.

**Approved for public release; distribution is unlimited**

By Order of the Secretary of the Army:

**DENNIS J. REIMER**  
*General, United States Army*  
*Chief of Staff*

Official:

  
JOEL B. HUDSON  
*Administrative Assistant to the*  
*Secretary of the Army*  
9911906

**DISTRIBUTION:**

To be distributed in accordance with the initial distribution number (IDN) 390560, requirements for TM 9-2330-202-14&P.



TECHNICAL MANUAL  
NO. 9-2330-202-14&P

HEADQUARTERS  
DEPARTMENT OF THE ARMY  
Washington D.C., 12 May 1997

**OPERATOR'S, UNIT, DIRECT SUPPORT, AND GENERAL SUPPORT  
MAINTENANCE MANUAL (INCLUDING REPAIR PARTS  
AND SPECIAL TOOLS LIST)**

**FOR**

**TRAILER, CARGO, 3/4-TON, 2-WHEEL  
M101A2 (2330-01-102-4697)  
M101 A3 (2330-01-372-5641)**

**TRAILER, CHASSIS, 3/4-TON, 2-WHEEL  
M116A2 (2330-01-101-8434)  
M116A2E1 (2330-01-333-9773)**

**TRAILER, CHASSIS, 1-TON, 2-WHEEL  
MI 116A3 (2330-01-359-0080)**

**REPORTING ERRORS AND RECOMMENDING IMPROVEMENTS**

You can help improve this manual. If you find any mistakes or if you know of a way to improve the procedures, please let us know. Mail your letter, DA Form 2028 (Recommended Changes to Publications and Blank Forms), or DA Form 2028-2, located in the back of this manual, directly to: Commander, U.S. Army Tank-automotive and Armaments Command, ATTN: AMSTA-IM-OPIT, Warren, MI 48397-5000. A reply will be furnished to you.

You may also provide DA Form 2028-2 information to TACOM via datafax or e-mail:

- TACOM's fax number is DSN 786-6323 or (810) 574-6323
- TACOM's e-mail address is amsta-mmaa@cc.tacom.army.mil

Approved for public release; distribution is unlimited.

**TABLE OF CONTENTS**

<b>HOW TO USE THIS MANUAL .....</b>	<b>Page vi</b>
<b>CHAPTER 1 INTRODUCTION</b>	
<b>Section I. General Information .....</b>	<b>1-1</b>

\*This publication supersedes TM 9-2330-202-14&P dated 7 October 1993.

**TABLE OF CONTENTS (continued)**

<b>CHAPTER</b>	<b>1</b>	<b>INTRODUCTION (continued)</b>	<b>Page</b>
	Section II.	Equipment Description and Data.....	1-4
	Section III.	Principles of Operation .....	1-17
<b>CHAPTER</b>	<b>2</b>	<b>OPERATING INSTRUCTIONS</b>	
	Section I.	Description and Use of Operator’s Controls and Indicators .....	2-1
	Section II.	Operator/Crew Preventive Maintenance Checks and Services (PMCS).....	2-3
	Section III.	Operation Under Usual Conditions.....	2-11
	Section IV.	Operation Under Unusual Conditions.....	2-26
<b>CHAPTER</b>	<b>3</b>	<b>OPERATOR/CREW MAINTENANCE INSTRUCTIONS</b>	
	Section I.	Lubrication Instructions.....	3-1
	Section II.	Operator/Crew Troubleshooting Procedures .....	3-2
<b>CHAPTER</b>	<b>4</b>	<b>UNIT MAINTENANCE</b>	
	Section I.	Repair Parts; Tools; Special Tools; Test, Measurement, and Diagnostic Equipment (TMDE); and Support Equipment.....	4-1
	Section II.	Service upon Receipt.....	4-2
	Section III.	Unit Preventive Maintenance Checks and Services (PMCS).....	4-3
	Section IV.	Unit Troubleshooting Procedures .....	4-7
	Section V.	General Maintenance Instructions.....	4-34
	Section VI.	Electrical System Maintenance .....	4-39
	Section VII.	Brake System Maintenance.....	4-49
	Section VIII.	Wheels, Hubs, and Brakedrums Maintenance .....	4-83
	Section IX.	Frame and Towing Attachments Maintenance.....	4-92
	Section X.	Springs and Shock Absorbers Maintenance .....	4-104
	Section XI.	Body Maintenance .....	4-110
	Section XII.	Accessory Items Maintenance .....	4-116
	Section XIII.	Special Purpose Kits Maintenance .....	4-119
	Section XIV.	Painting and Identification Marking .....	4-121
	Section XV.	Preparation for Storage and Shipment.....	4-122

**TABLE OF CONTENTS (continued)**

<b>CHAPTER</b>	<b>5</b>	<b>DIRECT SUPPORT AND GENERAL SUPPORT MAINTENANCE</b>	<b>Page</b>	
Section	I.	Axle Maintenance .....	5-1	
Section	II.	Brakedrum and Tire Maintenance .....	5-3	
Section	III.	Frame Assembly Maintenance .....	5-6	
Section	IV.	Accessory Items Maintenance.....	5-7	
<b>APPENDIX</b>	<b>A</b>	<b>REFERENCES</b> .....	A-1	
<b>APPENDIX</b>	<b>B</b>	<b>MAINTENANCE ALLOCATION CHART</b>		
Section	I.	Introduction .....	B-1	
Section	II.	Maintenance Allocation Chart for M101 and M116 Series Trailers .....	B-4	
Section	III.	Tool and Test Equipment Requirements .....	B-7	
Section	IV.	Remarks .....	B-7	
<b>APPENDIX</b>	<b>C</b>	<b>COMPONENTS OF END ITEM AND BASIC ISSUE ITEMS LISTS</b> .....	C-1	
<b>APPENDIX</b>	<b>D</b>	<b>ADDITIONAL AUTHORIZATION LIST</b>		
Section	I.	Introduction .....	D-1	
Section	II.	Additional Authorization List (AAL) .....	D-2	
<b>APPENDIX</b>	<b>E</b>	<b>REPAIR PARTS AND SPECIAL TOOLS LIST</b>		
Section	I.	Introduction .....	E-1	
Section	II.	Repair Parts List		
<b>GROUP</b>	<b>06</b>	<b>ELECTRICAL SYSTEM</b>	<b>Page</b>	<b>Illus/ Figure</b>
0609	-	LIGHTS.....	1-1	
		COMPOSITE STOPLIGHT-TAILLIGHT .....	1-1	1
0613	-	HULL OR CHASSIS WIRING HARNESS .....	2-1	
		CHASSIS WIRING HARNESS (COMPOSITE STOPLIGHT-TAILLIGHT) ...	2-1	2
		INTERVEHICULAR CABLE .....	3-1	3
		WIRING HARNESS AND INTERVEHICULAR CABLE ATTACHMENTS....	4-1	4

**TABLE OF CONTENTS (continued)**

			<b>Page</b>	<b>Illus/ Figure</b>
GROUP 11	REAR AXLE			
1100	- REAR AXLE ASSEMBLY .....		5-1	
	REAR AXLE ASSEMBLY .....		5-1	5
GROUP 12	BRAKES			
1201	- HANDBRAKES.....		6-1	
	CABLE AND CONDUIT ASSEMBLY.....		6-1	6
	HANDBRAKE LEVER.....		7-1	7
1202	- SERVICE BRAKES .....		8-1	
	BRAKE ASSEMBLY .....		8-1	8
1204	- HYDRAULIC BRAKE SYSTEM.....		9-1	
	WHEEL CYLINDER.....		9-1	9
	HYDRAULIC BRAKE ACTUATOR ASSEMBLY.....		10-1	10
	HYDRAULIC BRAKE LINES .....		11-1	11
GROUP 13	WHEELS AND TRACKS			
1311	- WHEEL ASSEMBLY .....		12-1	
	WHEEL AND HUB ASSEMBLY .....		12-1	12
	WHEEL AND RUNFLAT ASSEMBLY (M101A3 and M116A3).....		13-1	13
1313	- TIRES, TUBES, AND TIRE CHAINS.....		14-1	
	TIRE AND VALVE .....		14-1	14
GROUP 15	FRAME, TOWING ATTACHMENTS, DRAWBARS, AND ARTICULATION SYSTEMS			
1501	- FRAME ASSEMBLY.....		15-1	
	CHASSIS FRAME ASSEMBLY .....		15-1	15
1503	- PINTLES AND TOWING ATTACHMENTS .....		16-1	
	DRAWBAR ASSEMBLY AND SAFETY CHAINS.....		16-1	16
1507	- LANDING GEAR, LEVELING JACKS .....		17-1	
	FRONT SUPPORT LEG.....		17-1	17
GROUP 16	SPRINGS AND SHOCK ABSORBERS			
1601	- SPRINGS.....		18-1	
	SPRING ASSEMBLY.....		18-1	18
1604	- SHOCK ABSORBER EQUIPMENT .....		19-1	
	SHOCK ABSORBER.....		19-1	19
GROUP 18	BODY, CAB, HOOD, AND HULL			
1810	- CARGO BODY .....		20-1	
	CARGO BODY, RACK, AND TAILGATE ASSEMBLY (M101A2 and.....		20-1	20
	M101A3)			
GROUP 22	BODY, CHASSIS, AND HULL ACCESSORY ITEMS			
2201	- CANVAS, RUBBER, OR PLASTIC ITEMS .....		21-1	
	CANVAS COVER ASSEMBLY AND BOWS (M101A2 and M101A3).....		21-1	21

**TABLE OF CONTENTS (continued)**

			<b>Page</b>	<b>Illus/ Figure</b>
2202	-	ACCESSORY ITEMS .....	22-1	
		REFLECTOR (M101A2 and M101A3).....	22-1	22
2210	-	DATA PLATES AND INSTRUCTION HOLDERS .....	23-1	
		DATA PLATES .....	23-1	23
GROUP	33	SPECIAL PURPOSE KITS		
3307	-	SPECIAL PURPOSE KITS.....	24-1	
		REAR STABILIZER KIT .....	24-1	24
GROUP	95	GENERAL USE STANDARDIZED PARTS		
9501	-	BULK MATERIAL .....	BULK-1	
		BULK .....	BULK-1	BULK
Section	III	Special Tools List (If Applicable)		
Section	IV	Cross-Reference Indexes		
		PART NUMBER INDEX .....	I-1	
<b>APPENDIX</b>	<b>F</b>	<b>EXPENDABLE AND DURABLE ITEMS LIST</b>		
Section	I	Introduction.....	F-1	
Section	II	Expendable and Durable Items List.....	F-2	
<b>APPENDIX</b>	<b>G</b>	<b>ILLUSTRATED LIST OF MANUFACTURED ITEMS</b>		
Section	I	Introduction.....	G-1	
Section	II	Manufacturing Instructions .....	G-3	
<b>APPENDIX</b>	<b>H</b>	<b>TORQUE VALUES FOR THREADED FASTENERS .....</b>	H-1	
<b>APPENDIX</b>	<b>I</b>	<b>LUBRICATION INSTRUCTIONS.....</b>	I-1	
<b>INDEX</b>		.....	INDEX-1	

## HOW TO USE THIS MANUAL

---

### SCOPE.

---

This technical manual provides you with the information you will need to operate and maintain the M101 Series and M116 Series trailers.

The information contained in this manual is presented in five chapters and nine appendixes, one of which is a repair parts and special tools list (RPSTL). Each chapter is divided into sections covering operating procedures and/or other information for specific systems or components.

Note that Appendix A of this manual gives the full title of every manual, form, pamphlet, or other document referenced in this manual.

---

### INDEXING.

---

Four indexing procedures are used to help you locate information quickly:

- Cover index. Lists chapter titles and important parts of the manual, with corresponding page numbers. Each chapter or part listed is boxed in, with a black outer edge that is in line with the first page of that chapter or part.
- Table of contents. The table of contents, which follows the summary of warnings, lists all chapters and sections numerically, with corresponding page numbers.
- Section indexes. Each section starts with a numerical listing of all paragraphs in that section.
- Alphabetical index. The alphabetically arranged subject index starts on page Index-1.

---

### WARNINGS, CAUTIONS, AND NOTES.

---

You must read and understand this manual BEFORE operating the M101 Series and M116 Series trailers.

Throughout this manual you will see WARNING, CAUTION, and NOTE headings. There are good reasons for every one of these notices.

#### **WARNING**

A **WARNING** is used to alert the user to hazardous operating and maintenance procedures, practices, or conditions that could result in injury or death. **WARNINGS** must be strictly observed.

#### **CAUTION**

A **CAUTION** is used to alert the user to hazardous operating and maintenance procedures, practices, or conditions that could result in damage to, or destruction of, equipment or mission effectiveness. **CAUTIONS** must be strictly observed.

---

**WARNINGS, CAUTIONS, AND NOTES (continued).**

---

**NOTE**

A NOTE highlights an essential operating or maintenance procedure, condition, or statement.

WARNINGS and CAUTIONS appear immediately preceding the step to which they pertain. It is important to read and thoroughly understand the WARNINGS and/or CAUTIONS before beginning maintenance.

NOTES may precede or follow the steps to which they pertain, depending on what makes the most sense.

**vii/(viii blank)**





**CHAPTER 1  
INTRODUCTION**

**Section I. GENERAL INFORMATION**

<b>Paragraph Number</b>	<b>Paragraph Title</b>	<b>Page Number</b>
1-1	Scope .....	1-1
1-2	Maintenance Forms, Records, and Reports .....	1-1
1-3	Destruction of Army Materiel To Prevent Enemy Use .....	1-1
1-4	Preparation for Storage or Shipment .....	1-1
1-5	Quality Assurance .....	1-2
1-6	Reporting Equipment Improvement Recommendations (EIRs) .....	1-2
1-7	List of Abbreviations and Acronyms.....	1-2
1-8	Warranty Information .....	1-3
1-9	Safety, Care, and Handling.....	1-3
1-10	Corrosion Prevention and Control.....	1-3

**1-1. SCOPE.**

- a. This manual describes Operator's, Unit, Direct Support, and General Support maintenance and contains the repair parts and special tools list for the following:
- Trailer, Cargo: 3/4-Ton, 2-Wheel, M101A2 and M101A3;
  - Trailer, Chassis: 3/4-Ton, 2-Wheel, M116A2 and M116A2E1; and
  - Trailer, Chassis: 1-Ton, 2-Wheel, M116A3.
- b. All M101 Series cargo trailers use the M116 Series chassis.
- c. Throughout this manual, the terms "curb side" and "road side" are used to describe views of the trailer. As viewed from the rear, curb side is the right side and road side is the left side.
- d. The trailers are used to carry payloads over highway or cross-country.

**1-2. MAINTENANCE FORMS, RECORDS, AND REPORTS.**

Department of the Army forms and procedures used for equipment maintenance will be those prescribed by DA Pam 738-750, The Army Maintenance Management System (TAMMS).

**1-3. DESTRUCTION OF ARMY MATERIEL TO PREVENT ENEMY USE.**

Refer to TM 750-244-6 for procedures on the destruction of military vehicles to prevent enemy use.

**1-4. PREPARATION FOR STORAGE OR SHIPMENT.**

For information on preparing the trailers for storage or shipment, refer to Chapter 4, Section XV.

**1-5. QUALITY ASSURANCE.**

- a. No specific quality assurance manual pertains to the M101 or M116 Series of trailers.
- b. Defective material received through the supply system should be reported on an SF Form 368 (Product Quality Deficiency Report). Instructions for preparing the reports are provided in AR 702-7, Reporting of Product Quality Deficiencies Across Component Lines. Mail your completed form directly to:

Commander  
 U.S. Army Tank-automotive and Armaments Command  
 ATTN: AMSTA-TR-E/MPA  
 Warren, MI 48397-5000

**1-6. REPORTING EQUIPMENT IMPROVEMENT RECOMMENDATIONS (EIR'S).**

If your trailer needs improvement, let us know. Send us an EIR. You, the user, are the only one who can tell us what you don't like about the equipment. Let us know why you don't like the design or performance. Put it on an SF Form 368 and mail it to:

Commander  
 U.S. Army Tank-automotive and Armaments Command  
 ATTN: AMSTA-TR-E/MPA  
 Warren, MI 48397-5000

**1-7. LIST OF ABBREVIATIONS AND ACRONYMS.**

AAL	additional authorization list	NIIN	national item identification number
BII	basic issue items	N•m	newton meter
BOI	basic	NSN	national stock number
CAGEC	commercial and government entity code	OC	on condition
CARC	chemical agent resistant coating	p.	Page
COEI	components of end item	para	paragraph
CPC	corrosion prevent and control	PMCS	preventive maintenance checks and
services			
CTA	Common Table of Allowances	qty.	quantity
CUCV	commercial utility cargo vehicle	Qty. Recm.	quantity recommended
DA	Department of Army	Qty. Rqr.	quantity required
DoD	Department of Defense	RPSTL	repair parts and special tools list
E	empty	SMR	source, maintenance, and recoverability
EIR	equipment improvement recommendation	SN	serial number
GAA	grease, automotive and artillery	SOP	standard operating procedure
hr	hour	SRA	specialized repair activity
HMMWV	high-mobility multipurpose wheeled vehicle	TAMMS	The Army Maintenance Management
System			
IAW	in accordance with	TB	technical bulletin
JTA	Joint Table of Allowances	TDA	Table of Distribution and Allowances
kph	kilometers per hour	TM	technical manual
L	liter	TMDE	test, measurement, and diagnostic
equipment			
LED	light-emitting diode	TOE	Table of Organization and Equipment
MAC	maintenance allocation chart	U/M	unit of measure
MOS	military occupational specialty	UOC	usable-on code
MTOE	Modified Table of Organization and Equipment	V dc	volts, direct current
MWO	modification work order	W/	with
NBC	nuclear biological and chemical	W/O	without

---

**1-8. WARRANTY INFORMATION.**

---

The M101 and M1 6 Series trailers are not warranted.

---

**1-9. SAFETY, CARE, AND HANDLING.**

---

For information on general safety precautions and regulations, review the warning summary at the front of this manual preceding the table of contents. Observe all WARNINGS and CAUTIONS that appear in the maintenance procedures.

---

**1-10. CORROSION PREVENTION AND CONTROL.**

---

- a. Corrosion prevention and control (CPC) of Army materiel is a continuing concern. It is important that any corrosion problem with this item be reported so the problem can be corrected and improvements can be made to prevent the problem in future items.
- b. While corrosion is typically associated with the rusting of metals, it can also include deterioration of other materials, such as rubber and plastic. Unusual cracking, softening, swelling, or breaking of these materials may be a corrosion problem.
- c. If a corrosion problem is identified, it can be reported using an SF Form 368. The use of key words, such as "corrosion," "rust," "deterioration," and "cracking," will ensure that the information is identified as a CPC problem. The form should be submitted to the address specified in DA Pam 738-750.

**Section II. EQUIPMENT DESCRIPTION AND DATA**

<b>Paragraph Number</b>	<b>Paragraph Title</b>	<b>Page Number</b>
1-11	Equipment Characteristics, Capabilities, and Features .....	1-4
1-12	Location and Description of Major Components .....	1-5
1-13	Location and Contents of Data Plates .....	1-10
1-14	Differences Between Models .....	1-12
1-15	Equipment Data .....	1-14

**1-11. EQUIPMENT CHARACTERISTICS, CAPABILITIES, AND FEATURES.**

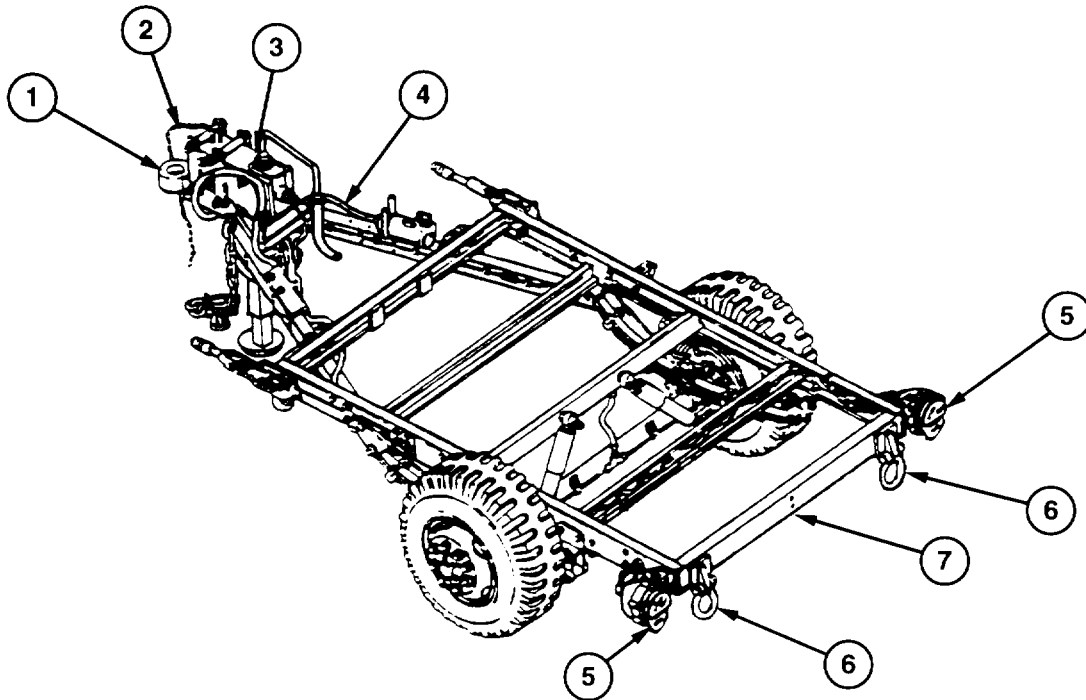
**a. CHARACTERISTICS**

1. All trailers are designed to be towed by a towing vehicle without airbrake connections. A handbrake lever and cable assembly located on each side of the trailer activates a handbrake at each wheel. Control of each handbrake is independent.
2. In addition to handbrake lever-activated handbrakes, the trailers are equipped with an inertia-actuated hydraulic brake system. For principles of operation of this system, refer to Section III of this chapter.
3. All trailers have a single axle with two wheels.
4. The trailer suspension consists of two leaf spring assemblies and shock absorbers.
5. The M116A2E1 and M1 16A3 are equipped with a dropped axle, frame, and spring assemblies that allow for a greater payload than the other models.
6. The cargo body, which is a feature of M101 Series trailers, can be easily removed. The old-style cargo body is being phased out. The new-style cargo body adds reinforcements and U-bolt lift points to ensure that the cargo body can be lifted without danger and without using spreader bars.
7. A rear stabilizer may be added to provide greater stability when the trailer is carrying generator sets. Use of the stabilizer is optional for all other applications.

**b. CAPABILITIES AND FEATURES**

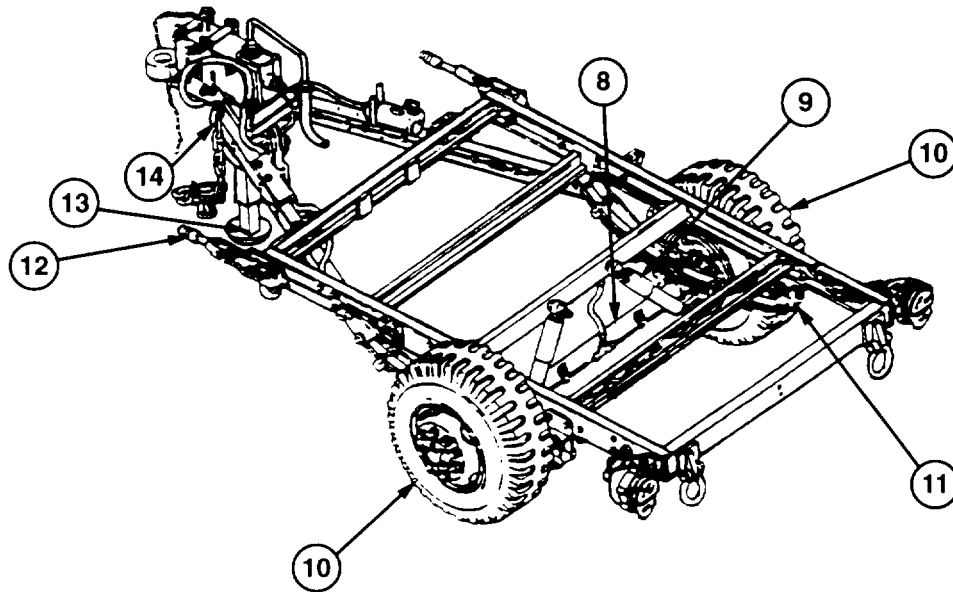
1. Maximum towing speeds with maximum payload evenly distributed are: highway, 50 miles per hour (80 kph); and cross-country, 6 miles per hour (10 kph).
2. Maximum payload varies with model designation. Refer to paragraph 1-15.
3. The cargo capacity of the M101 Series trailers may be increased by installing a rack and tailgate assembly. A canvas cover assembly may be used to protect cargo from the weather.

1-12. LOCATION AND DESCRIPTION OF MAJOR COMPONENTS.



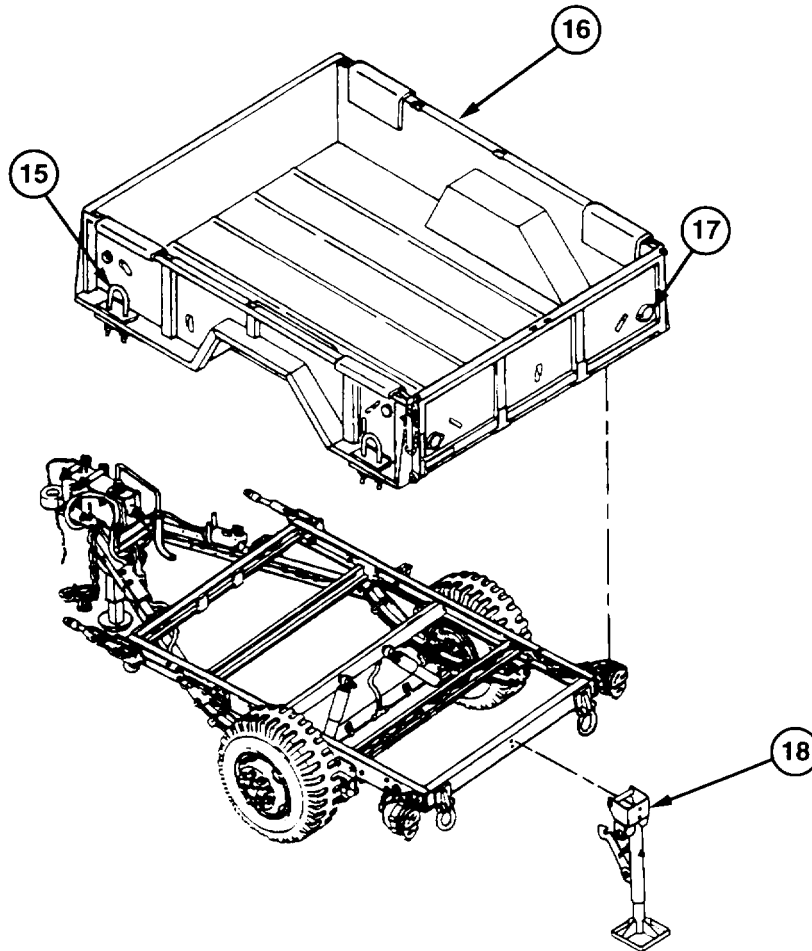
Key	Component	Description
1	Drawbar Coupler	Couples trailer to towing vehicle pintle.
2	Breakaway Chain	Provides for emergency braking of trailer. Attaches to towing vehicle and applies brakes in the event trailer breaks away from towing vehicle.
3	Hydraulic Brake Actuator Assembly	Transmits braking forces from towing vehicle to trailer and service brakes by means of a drawbar coupler, master cylinder, hydraulic brake tubes and hose, and wheel cylinders.
4	Intervehicular Cable	Provides electrical connection between trailer and towing vehicle.
5	Composite Light	Indicates trailer presence to vehicles traveling behind. Consists of blackout light, service light, turn signal, and stoplight. Located at each side of trailer rear.
6	Tiedown Shackles	Secures trailer during shipment. Located at each front and rear corner of chassis.
7	Chassis	Provides mounting for cargo body of M101 Series trailers. Frame assembly common to all models.

1-12. LOCATION AND DESCRIPTION OF MAJOR COMPONENTS (continued).



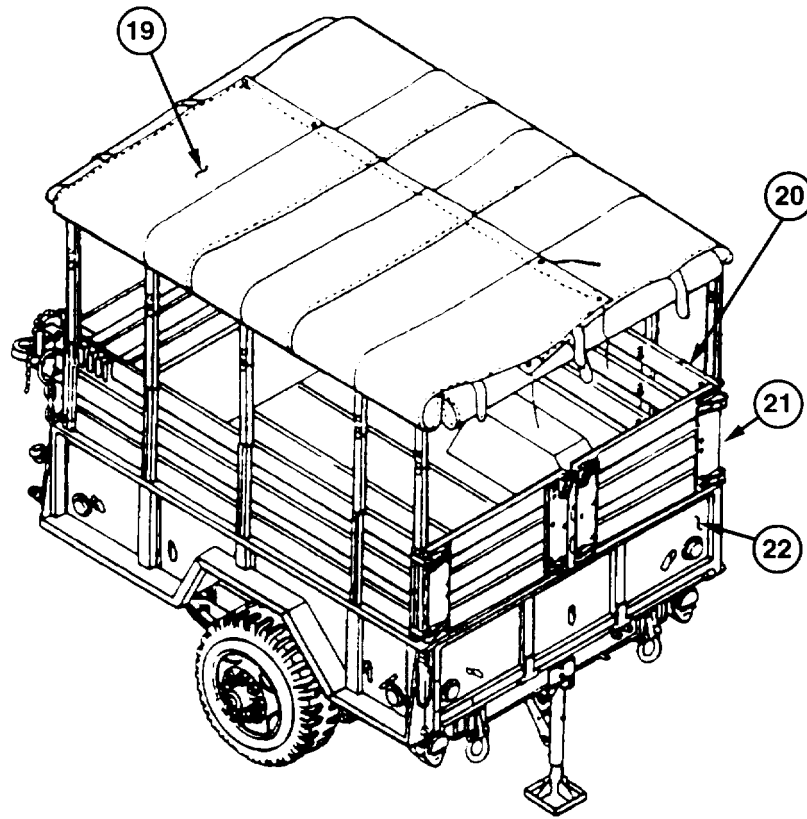
Key	Component	Description
8	Axle	Carries wheels and allows wheels to rotate. Tubular weldment on which trailer wheels and suspension components are mounted.
9	Shock Absorber	Dampens spring action. Located on each end of axle.
10	Wheel and Tire Assembly	Supports trailer load. Attached to each end of axle.
11	Spring Assembly	Supports trailer load and absorbs road shock. Located on each side of frame.
12	Handbrake Lever	Applies handbrake when trailer is stopped or parked. Located on each side of chassis.
13	Front Support Leg	Supports trailer when uncoupled from towing vehicle. All trailers have an adjustable front support leg.
14	Safety Chain	Prevents trailer from fully breaking away. Hooks to towing vehicle shackles. Located on each side of drawbar assembly.

1-12. LOCATION AND DESCRIPTION OF MAJOR COMPONENTS (continued).



Key	Component	Description
15	U-bolt (M101 A2 and M 101A3)	Provides lift points for new-style cargo body. Located at each of four lower corners of cargo body.
16	Cargo Body (M101A2 and M101A3)	Carries cargo. A welded box assembly attached to frame.
17	Reflector (M101A2 and M101A3)	Indicates trailer presence to vehicles traveling behind. Located at lower corners of all sides of cargo body.
18	Rear Stabilizer	Prevents trailer from tipping over when loading and unloading cargo. Required when trailer is carrying generator sets.

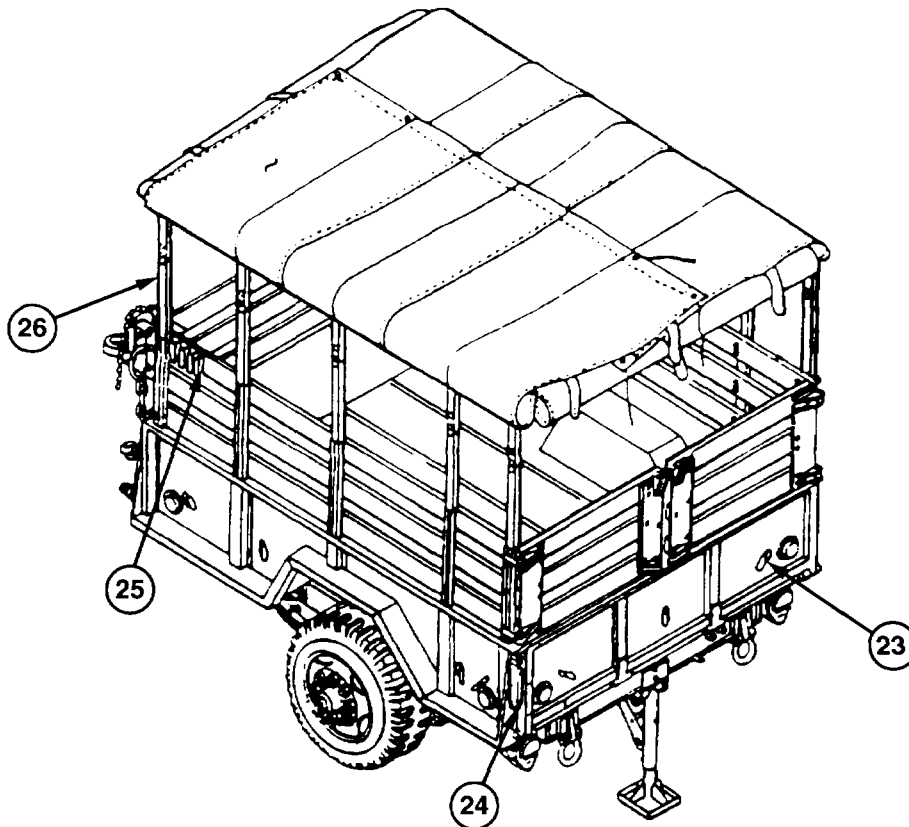
1-12. LOCATION AND DESCRIPTION OF MAJOR COMPONENTS (continued).



Key	Component	Description
19	Canvas Cover Assembly (M101A2 and M101A3)	Protects cargo from weather.
20	Rack Assembly (M101A2 and M101A3)	Increases cargo volume capacity. Consists of one front rack assembly, two side rack assemblies, and a two-section tailgate assembly. Earlier-model rack assemblies are wooden. Newer-model rack assemblies are made of composite material.
21	Tailgate Assembly (M101A2 and M101A3)	Opens outward from center for ease in loading and unloading cargo. This two-section hinged tailgate assembly is a component of the rack assembly. Earlier-model tailgate assemblies are wooden. Newer-model tailgate assemblies are made of composite material.
22	Tailgate (M101 A2 and M101 A3)	Swings down for ease in loading and unloading cargo. This one-piece tailgate is secured in position by two chain and pin assemblies.



1-12. LOCATION AND DESCRIPTION OF MAJOR COMPONENTS (continued).



Key	Component	Description
23	Cargo Hook (M101A2 and M101A3)	Secures canvas cover assembly to the cargo body. Located on all four sides of cargo body (six on front and rear, eight on left and right sides).
24	Chain and Pin Assembly (M101A2 and M101A3)	Secures cargo body tailgate in position. Located at both upper rear corners of cargo body.
25	Bow Clip (M101A2 and M101A3)	Stows bow assemblies. Located on front corner of each side rack assembly.
26	Bow Assembly (M101A2 and M101A3)	Supports canvas cover assembly. Five bow assemblies fit across rack assembly. Earlier-model bow assemblies are wooden. Newer-model bow assemblies are made of steel.

1-13. LOCATION AND CONTENTS OF DATA PLATES.

M101A2 and M101A3 Cargo Trailers

**TIE DOWN DATA**  
DIMENSIONS ARE SYM ABOUT  $\phi$  OF TRAILER

PROVIDE SUPPORT BLOCKS BETWEEN TRAILER AND DECK AS SHOWN (4) LOCATIONS. MIN. CAPACITY OF ALL TIE DOWN CHAINS IS 10,000 LBS

**LIFT DATA**

FRONT EYE    REAR EYE  
CAPACITY/EYE    2765    2765  
CABLE SIZE    .38 DIA MIN    .38 DIA MIN  
CABLE LENGTH    144.0 MIN    144.0 MIN  
\* TYPE I OR II PER: FED. SPEC. RR-W-410



TRAILER - CARGO - 3/4 TON - 2W - M101 - A2

NATIONAL STOCK NUMBER

MANUFACTURED BY  
GARWOOD INDUSTRIES, INC    WAYNE, MICH    USA

MFR SER NO     YR MFD

MFR PART NO 7339495    MODEL M101-A2

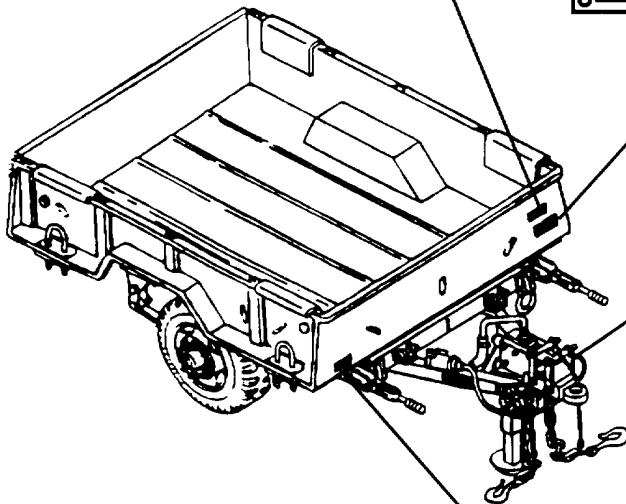
CONTRACT NO DA-20-113-ORD-27978

PUBLICATIONS  
PARTS LIST  
TECH MANUAL

DELIVERY DATE     INSPECTED

**WEIGHT AND DIMENSION DATA**

WEIGHTS	EMPTY	CROSS COUNTRY	HIGHWAY	SHIPPING CUBAGE 520 CU. FT.
PAYLOAD		1500	2250	
WHEELS	1225	2640	3380	
LOG LEG	115	200	230	
TOTAL	1340	2640	3580	



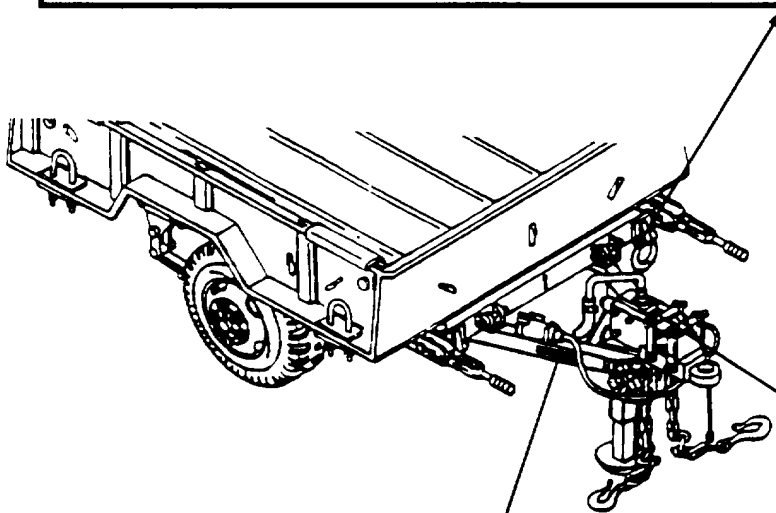
**CAUTION**  
ADD SILICONE BRAKE  
FLUID ONLY  
MIL-B-46176

RESPONSIBLE AGENCY	PROCUREMENT	DEPOT MAINTENANCE
CHASSIS	ORDNANCE CORPS	ORDNANCE CORPS
BODY	ORDNANCE CORPS	ORDNANCE CORPS
MTD. EQUIP.		

1-13. LOCATION AND CONTENTS OF DATA PLATES (continued).

M116A2, M116A2E1, and M116A3 Chassis Trailers

CHASSIS TRAILER CARGO, 3/4 TON, 2W, M116A2E2 NATIONAL STOCK NO. MFD BY VEH IDENT NO. CONTRACT NO.		DELIVERY DATE <input style="width: 100%; height: 20px;" type="text"/>															
PUBLICATIONS TECH MANUAL	<table border="1" style="width: 100%; border-collapse: collapse;"> <thead> <tr> <th style="text-align: left;">WEIGHT</th> <th style="text-align: center;">EMPTY</th> <th style="text-align: center;">LOADED</th> </tr> </thead> <tbody> <tr> <td>PAYLOAD</td> <td style="text-align: center;">—</td> <td style="text-align: center;">2500</td> </tr> <tr> <td>WHEELS</td> <td style="text-align: center;">675</td> <td style="text-align: center;">3035</td> </tr> <tr> <td>LUNETTE</td> <td style="text-align: center;">125</td> <td style="text-align: center;">265</td> </tr> <tr> <td>TOTAL</td> <td style="text-align: center;">800</td> <td style="text-align: center;">3300</td> </tr> </tbody> </table>	WEIGHT	EMPTY	LOADED	PAYLOAD	—	2500	WHEELS	675	3035	LUNETTE	125	265	TOTAL	800	3300	SHIPPING CUBAGE 189 CU. FT. INSPECTED <input style="width: 100%; height: 20px;" type="text"/>
WEIGHT	EMPTY	LOADED															
PAYLOAD	—	2500															
WHEELS	675	3035															
LUNETTE	125	265															
TOTAL	800	3300															



CAUTION  
 ADD SILICONE BRAKE  
 FLUID ONLY  
 MIL-B-46176

<h3 style="text-align: center;">TIE DOWN DATA</h3> <p style="text-align: center; border: 1px solid black; padding: 2px;">DIMENSIONS ARE SYM ABOUT Q OF TRAILER</p> <p style="font-size: small;">PROVIDE SUPPORT BLOCKS BETWEEN TRAILER AND DECK AS SHOWN * (4) LOCATIONS. MIN. CAPACITY OF ALL TIE DOWN CHAINS IS 10,000 LBS</p>	<h3 style="text-align: center;">LIFT DATA</h3> <table border="1" style="width: 100%; border-collapse: collapse; font-size: small;"> <thead> <tr> <th></th> <th style="text-align: center;">FRONT EYE</th> <th style="text-align: center;">REAR EYE</th> </tr> </thead> <tbody> <tr> <td>CAPACITY/EYE</td> <td style="text-align: center;">2760 LBS.</td> <td style="text-align: center;">2520 LBS.</td> </tr> <tr> <td>CABLE SIZE *</td> <td style="text-align: center;">.38 DIA. MIN.</td> <td style="text-align: center;">.38 DIA. MIN.</td> </tr> <tr> <td>CABLE LENGTH</td> <td style="text-align: center;">74. MIN</td> <td style="text-align: center;">74. MIN</td> </tr> </tbody> </table> <p style="font-size: x-small; text-align: center;">* TYPE I OR II PER: FED. SPEC. RR-W-410</p>		FRONT EYE	REAR EYE	CAPACITY/EYE	2760 LBS.	2520 LBS.	CABLE SIZE *	.38 DIA. MIN.	.38 DIA. MIN.	CABLE LENGTH	74. MIN	74. MIN
	FRONT EYE	REAR EYE											
CAPACITY/EYE	2760 LBS.	2520 LBS.											
CABLE SIZE *	.38 DIA. MIN.	.38 DIA. MIN.											
CABLE LENGTH	74. MIN	74. MIN											

**1-14. DIFFERENCES BETWEEN MODELS.**

**a. GENERAL**

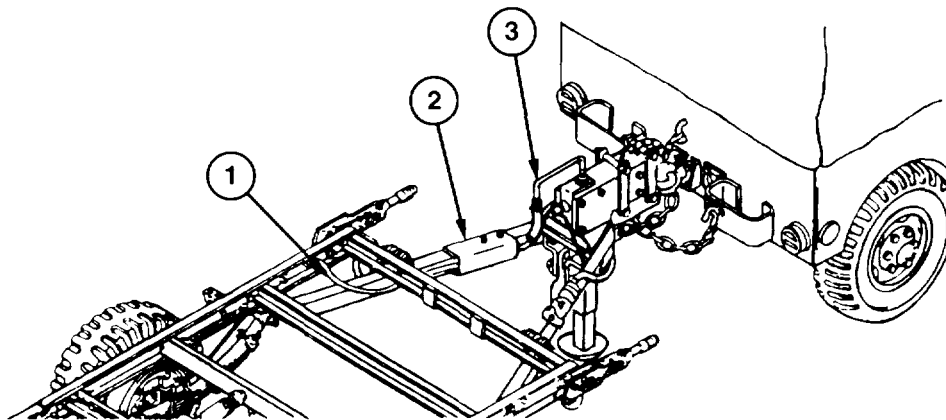
1. Differences between trailers consist of configuration variations in the electrical system, axle, brakes, wheels, frame, and suspension.
2. The major trailer differences are summarized In Table 1-1.

**Table 1-1. Differences Between Models**

Model	Axle	Inertia Brake System	Wheels/Tires	Frame	Spring Leaves
M101A2	Straight	Yes	Tubeless/Bias	3 in. (7.62 cm)	5
M101A3	Offset	Yes	Tubeless/Bias and Runflat/Radial	4 in. (10.16 cm)	6
M116A2	Straight	Yes	Tubeless/Bias	3 in. (7.62 cm)	5
M116A2E1	Straight	Yes	Tubeless/Bias	4 in. (10.16 cm)	6
M116A3	Offset	Yes	Tubeless/Bias and Runflat/Radial	4 in. (10.16 cm)	6

**b. ELECTRICAL SYSTEM**

1. Trailers are equipped with a chassis wiring harness (1) that terminates at a covered junction box (2) on the road-side drawbar. The intervehicular cable (3) is fixed to the trailer.
2. Trailers are equipped with a two-light composite stoplight-tailight configuration that may have standard lamps or LEDs.



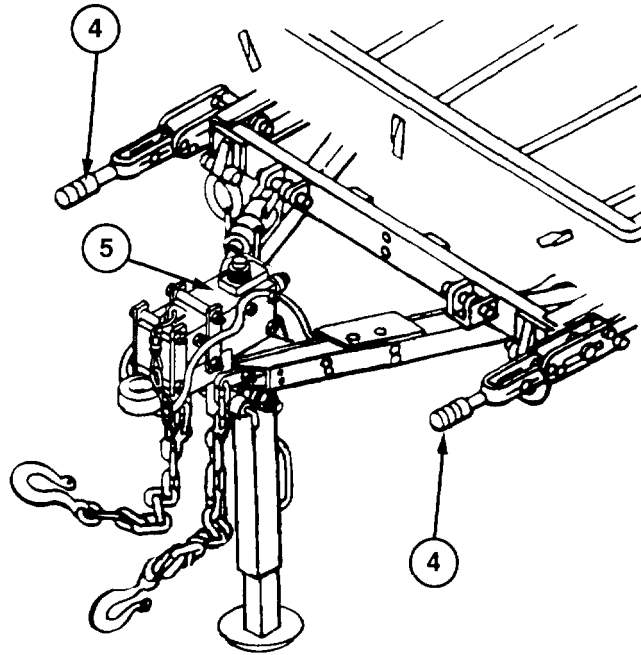
---

**1-14. DIFFERENCES BETWEEN MODELS (continued).**

---

**c. BRAKE SYSTEM**

1. The handbrake levers (4) are located at the front corners of the frame. Adjustment of one of these levers is made at the lever itself.
2. The trailers have both handbrakes and an inertia-actuated hydraulic brake system (5) (para 1-16).

**d. AXLE, FRAME, AND SUSPENSION**

The MI 16A2E1 and MI 16A3 are variants of the MI 16A2. Heavy-duty axles, four-inch frames, and spring assemblies allow for a greater payload than the M116A2 (para 1-15). In addition, the M116A3 uses the HMMWV radial runflat wheel and tire assemblies.

**1-15. EQUIPMENT DATA.**

**Components Common to All Models**

ELECTRICAL SYSTEM .....24 V dc

AXLE .....Tubular Weldment

**TIRES**

Quantity .....2

Ply .....8

Size .....9 x 16 in. (23 x 41 cm)

Inflation Pressure:

M101A3 and M116A3 (Runflat/Radial).....30 psi (207 kPa)

Bias (All Except M101A3 and M116A3)

Highway .....35 psi (241 kPa)

Sand .....30 psi (207 kPa)

**WHEELS**

Rim Size .....16 x 6.5 in. (43 x 16 cm)

**SUSPENSION**

Spring Assemblies.....Semielliptical

Shock Absorbers .....Hydraulic, Double-acting

**HANDBRAKES**

Actuation.....Mechanical

Location .....Front of Frame

Quantity .....2

**TOWING SPEEDS**

Highway .....50 mph (80 kph)

Cross-country .....6 mph (10 kph)

**M101A2, M101A3, AND M116A2**

**GENERAL**

Angle of Departure .....30°

Center of Gravity (Measured from Center of Rear Axle):

Empty.....45 3/4 in. (116.21 cm)

Loaded.....36 1/4 in. (92.08 cm)

Shipping Volume of Chassis Trailer .....213 cu ft (5.96 cu m)

Shipping Volume of Cargo Trailer .....520 cu ft (14.56 cu m)

**DIMENSIONS**

Overall:

Length .....147 in. (373.38 cm)

Width .....73.5 In. (186.69 cm)

Height of Chassis .....35 in. (88.9 cm)

Height of Cargo Trailer (M101A2 and M101A3):

Empty.....83 in. (210.82 cm)

Loaded.....79 In. (200.66 cm)

**1-15. EQUIPMENT DATA (continued).**

Cargo Body (Old Style):

Length.....	76 in. (193.04 cm)
Width .....	65.5 in. (166.37 cm)
Height .....	18 in. (45.72 cm)
Tread .....	72 in. (182.88 cm)

Cargo Body (New Style) (M101A2 and M101A3):

Length.....	100 in. (254 cm)
Width .....	73.5 in. (186.69 cm)
Height .....	19.84 in. (50.39 cm)

**TOWING INFORMATION**

Towing Attachment .....	Drawbar Coupler
Towing Vehicle .....	CUCV Series, HMMWV
Series, 2-1/2 Ton series,	
5 Ton series	

**WEIGHTS**

Payload (Maximum):

Cross-country .....	1500 lb (681 kg)
Highway .....	2250 lb (1021.5 kg)

Empty:

Wheels .....	1225 lb (556.15 kg)
Front Support Leg.....	115 lb (52.21 kg)
Total	1340 lb (608.36 kg)

With Payload:

Wheels	
Cross-country.....	2640 lb (1198.56 kg)
Highway .....	3360 lb (1525.44 kg)
Front Support Leg	
Cross-country.....	200 lb (90.8 kg)
Highway .....	230 lb (104.42 kg)
Total	
Cross-country.....	2840 lb (1289.36 kg)
Highway .....	3590 lb (1629.86 kg)

**M116A2E1**

**GENERAL**

Angle of Departure .....	30°
Center of Gravity:	
Empty .....	15.3 in. (38.86 cm)
Loaded.....	8.3 in. (21.08 cm)
Shipping Volume of Chassis Trailer .....	189 cu ft (5.29 cu m)

**DIMENSIONS**

Length .....	145.7 in. (370.08 cm)
Width .....	71.3 in. (181.1 cm)
Height of Chassis .....	30 in. (76.2 cm)
Tread .....	71.3 in. (181.1 cm)

1-15. EQUIPMENT DATA (continued).

**TOWING INFORMATION**

Towing Attachment ..... Drawbar Coupler  
 Towing Vehicle ..... CUCV Series, HMMWV  
 Series, 2-1/2 Ton series,  
 5 Ton series

**WEIGHTS**

Payload (Maximum) ..... 2380 lb (1080.52 kg)  
 Empty:  
     Wheels ..... 661 lb (300.09 kg)  
     Lunette ..... 119 lb (54.03 kg)  
     Total ..... 780 lb (354.12 kg)  
 Loaded:  
     Wheels ..... 2899 lb (1316.15 kg)  
     Lunette ..... 261 lb (118.49 kg)  
     Total ..... 3160 lb (1434.64 kg)

**M116A3**

**GENERAL**

Angle of Departure ..... 30  
 Center of Gravity:  
     Empty ..... 16 in. (40.64 cm)  
     Loaded ..... 8.2 in. (20.83 cm)  
 Shipping Volume of Chassis Trailer ..... 189 cu ft (5.29 cu m)

**DIMENSIONS**

Length ..... 145.7 in. (370.08 cm)  
 Width ..... 81.5 in. (207.01 cm)  
 Height of Chassis ..... 36 in. (91.44 cm)  
 Tread ..... 81.5 in. (207.01 cm)

**TOWING INFORMATION**

Towing Attachment ..... Drawbar Coupler  
 Towing Vehicle ..... CUCV Series, HMMWV  
 Series, 2 1/2 ton series,  
 5 ton series

**WEIGHTS**

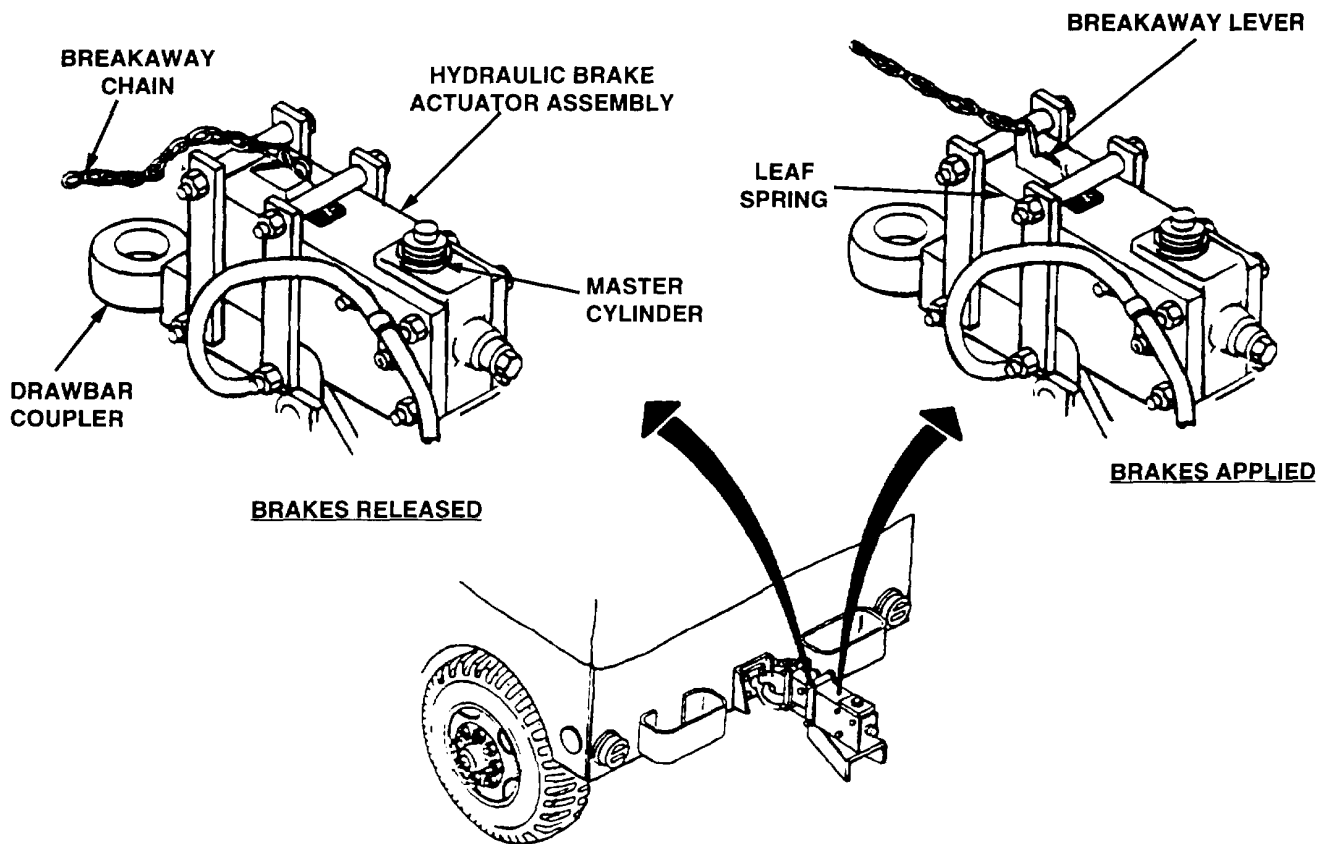
Payload (Maximum) ..... 2360 lb (1071.44 kg)  
 Empty:  
     Wheels ..... 675 lb (306.45 kg)  
     Lunette ..... 125 lb (56.75 kg)  
     Total 800 lb (363.2 kg)  
 Loaded:  
     Wheels ..... 2905 lb (1 318.87 kg)  
     Lunette ..... 255 lb (115.77 kg)  
     Total ..... 3160 lb (1434.64 kg)



## Section III. PRINCIPLES OF OPERATION

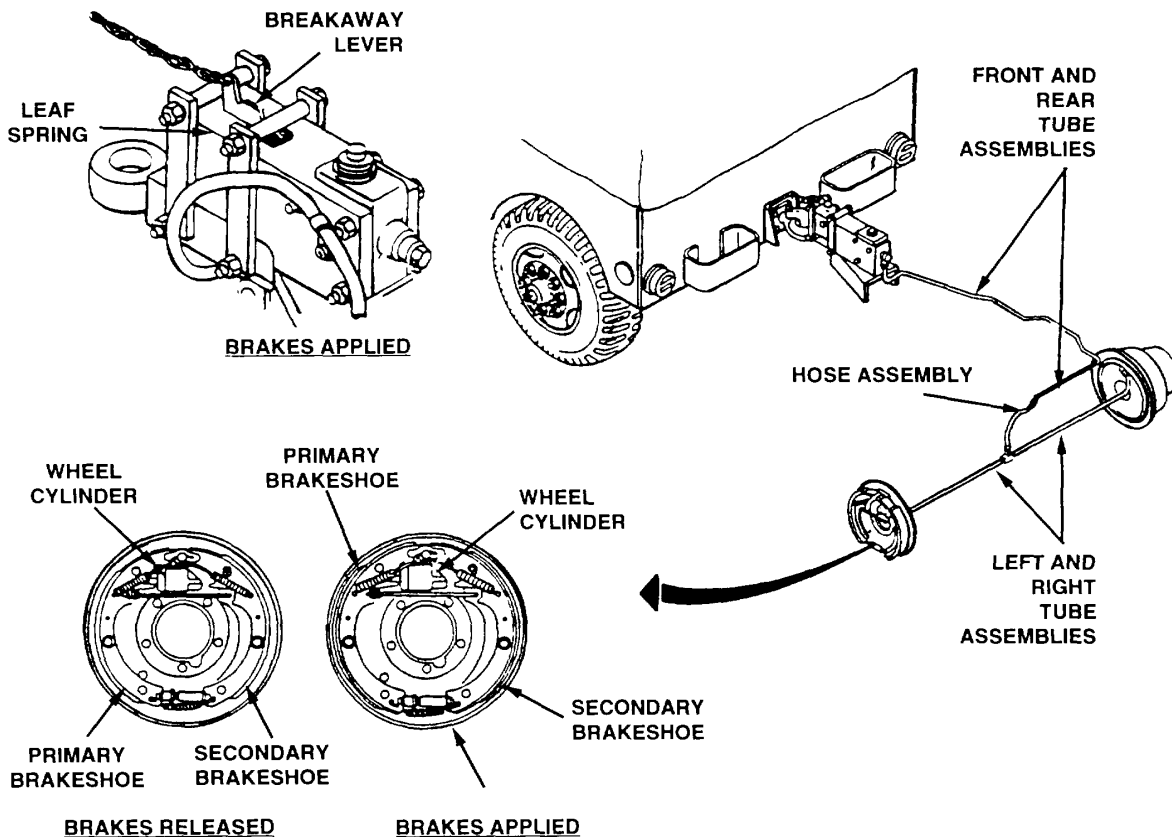
**1-16. HYDRAULIC BRAKE SYSTEM.**

- a. Brakes are applied automatically by the hydraulic brake system when the towing vehicle slows or stops, or when the trailer breaks away from the towing vehicle.
- b. The major components of the hydraulic brake system and their functions are as follows:
  1. Hydraulic Brake Actuator Assembly. This assembly transmits the braking forces of the towing vehicle to the trailer by inertia. It consists of a drawbar coupler, master cylinder, breakaway chain and lever, and leaf spring.
  2. Drawbar Coupler. The drawbar coupler attaches to the towing vehicle and controls the master cylinder. When the towing vehicle goes forward, the drawbar coupler is pulled and the brakes are released. When the towing vehicle slows down, the trailer pushes the drawbar ring into the towing vehicle and applies the brakes.
  3. Master Cylinder. The master cylinder changes the mechanical motion of the drawbar coupler and breakaway lever into hydraulic pressure. It has a built-in shock absorber to prevent jerky drawbar coupler movement. The shock absorber prevents hydraulic pressure from building up when the towing vehicle backs up.
  4. Breakaway Chain. The breakaway chain is attached to the towing vehicle. If the trailer breaks away from the towing vehicle, the breakaway chain will pull up on the breakaway lever and apply the brakes.



**1-16. HYDRAULIC BRAKE SYSTEM (continued).**

5. Breakaway Lever. The breakaway lever is activated by the breakaway chain and controls the master cylinder. When the breakaway lever is up, the brakes are applied. When the breakaway lever is down, the drawbar coupler movement controls the master cylinder.
6. Leaf Spring. The leaf spring holds the breakaway lever up. The breakaway lever must be reset any time it has been pulled up.
7. Hydraulic Brake Tube Assemblies and Hose Assembly. These components transfer hydraulic pressure from the master cylinder to the wheel cylinders.
8. Wheel Cylinders. One wheel cylinder is located at each wheel. The wheel cylinder changes hydraulic pressure into mechanical motion. When the wheel cylinder is pressurized, it pushes the primary and secondary brakeshoes against the brakedrum.
9. Primary Brakeshoe. The primary brakeshoe is pushed against the brakedrum by the wheel cylinder. The brakedrum pushes the primary brakeshoe down and into the secondary brakeshoe.
10. Secondary Brakeshoe. The secondary brakeshoe provides braking action. It is pushed into the brakedrum by the primary brakeshoe.



**CHAPTER 2  
OPERATING INSTRUCTIONS**

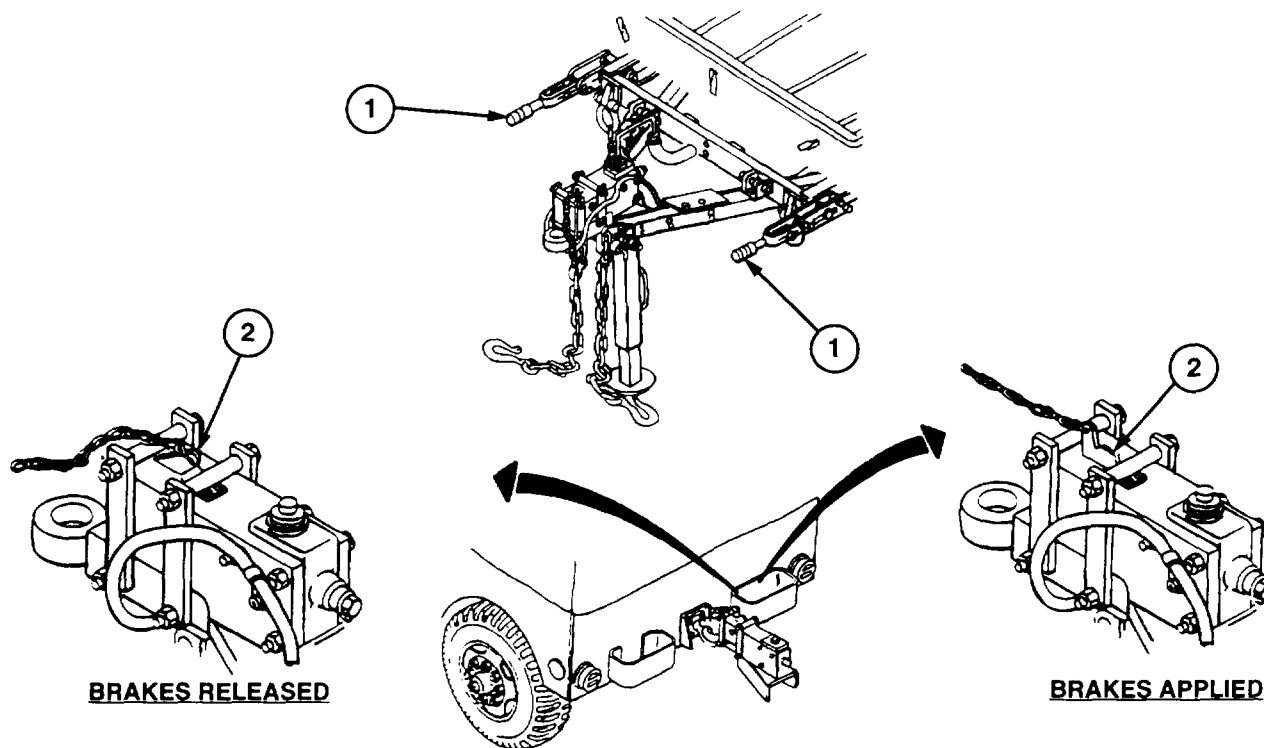
**Section I. DESCRIPTION AND USE OF OPERATOR'S CONTROLS AND INDICATORS**

Paragraph Number	Paragraph Title	Page Number
2-1	General .....	2-1
2-2	Controls and Indicators .....	2-1

**2-1. GENERAL.**

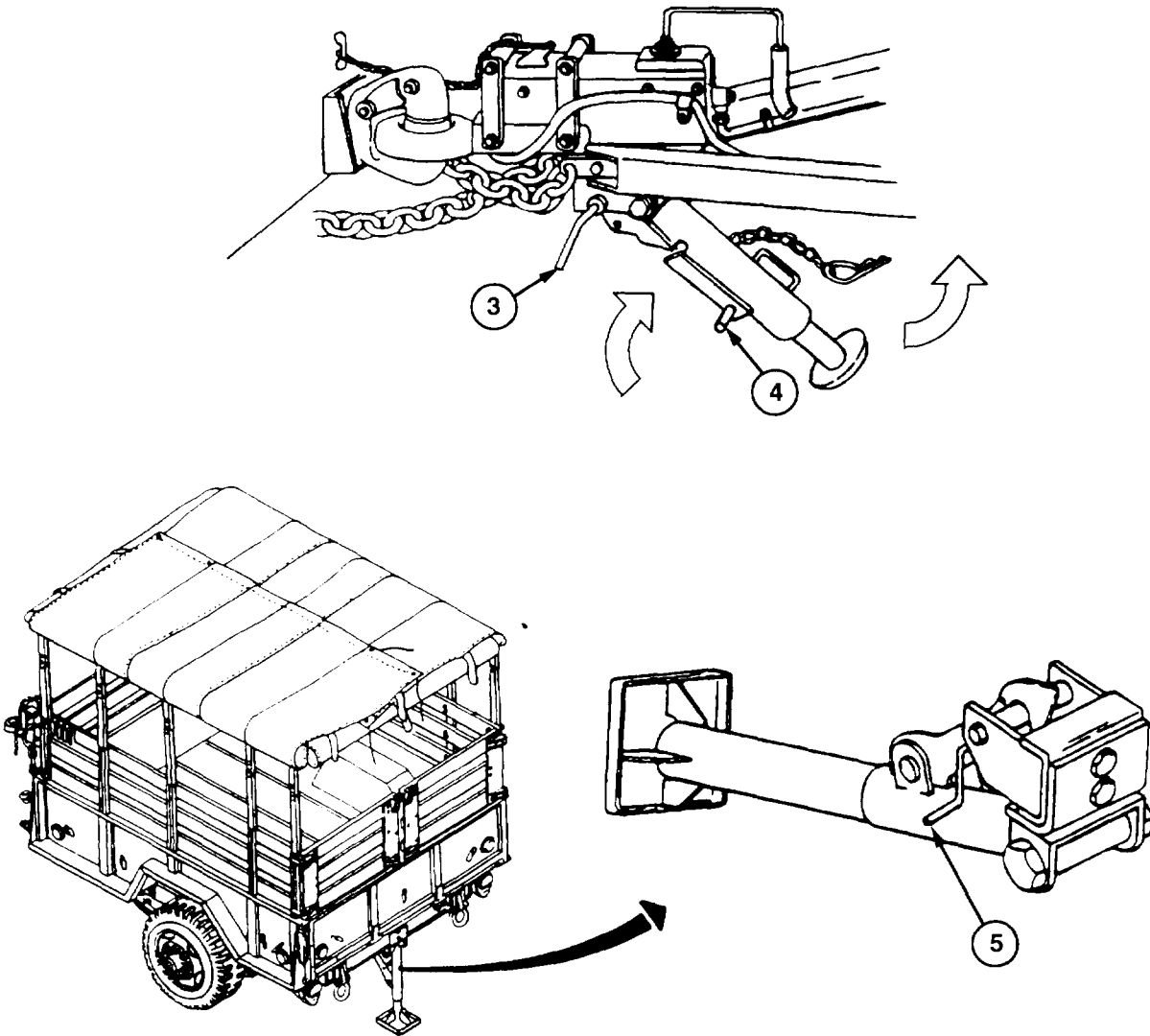
This section shows the location and describes the function of all controls and indicators. Review this section thoroughly before operating the trailer.

**2-2. CONTROLS AND INDICATORS.**



KEY	CONTROL or INDICATOR	FUNCTION
1	Handbrake Levers	Apply and release handbrakes
2	Breakaway Lever	Applies brakes in emergency situations. May be reset to release brakes

2-2. CONTROLS AND INDICATORS (continued).



KEY	CONTROL or INDICATOR	FUNCTION
3	Plunger	Holds or locks adjustable front support leg in raised or lowered position.
4	Handcrank	Rotates to adjust height of adjustable front support leg.
5	Release Handle	Holds or locks rear stabilizer in raised or lowered position.

**Section II. OPERATOR/CREW PREVENTIVE MAINTENANCE  
CHECKS AND SERVICES (PMCS)**

<b>Paragraph Number</b>	<b>Paragraph Title</b>	<b>Page Number</b>
2-3	General .....	2-3
2-4	Service Intervals .....	2-3
2-5	Reporting Repairs.....	2-3
2-6	General PMCS Procedures .....	2-4
2-7	Specific PMCS Procedures .....	2-4
2-8	Leakage Definitions .....	2-5
Table 2-1 Operator/Crew Preventive Maintenance Checks and Services (PMCS) for the M101 and M116 Series Trailers .....		2-6

---

**2-3. GENERAL.**

---

- a. To ensure that the M 101 and M116 Series trailers are ready for operation at all times, they must be inspected on a regular basis so that defects may be found before they result in serious damage, equipment failure, or injury to personnel. This section contains systematic instructions on inspections, adjustments, and corrections to be performed by the operator/crew.
- b. While performing preventive maintenance checks and services (PMCS), read and follow all safety instructions found in the warning summary at the beginning of this manual. Keep in mind all WARNINGS and CAUTIONS.

---

**2-4. SERVICE INTERVALS.**

---

Perform the PMCS procedures listed in Table 2-1 at the following intervals:

- Perform *Before* PMCS just before operating the trailer.
- Perform *During* PMCS while operating the trailer.
- Perform *Weekly* PMCS once each week.
- Perform *Monthly* PMCS once each month.

---

**2-5. REPORTING REPAIRS.**

---

All defects that the operator cannot fix must be reported on a DA Form 2404, *Equipment Inspection and Maintenance Worksheet*, immediately after completing PMCS. If a serious problem is found, IMMEDIATELY report it to your supervisor.

---

**2-6. GENERAL PMCS PROCEDURES.**


---

**WARNING**

**Drycleaning solvent P-D-680 is toxic and flammable. Always wear protective goggles and gloves, and use only in a well-ventilated area. Avoid contact with skin, eyes, and clothes, and DO NOT breathe vapors. DO NOT use near open flame or excessive heat.**

a. Keep equipment clean. Dirt, oil, and debris may cover up a serious problem. Clean as you work and as needed. Use drycleaning solvent (Item 15, Appendix F) on all metal surfaces. Use detergent (Item 5, Appendix F) and water on rubber, plastic, and painted surfaces.

b. While performing specific PMCS procedures, inspect the following components:

**Bolts, Nuts, and Screws.** Make sure they are not loose, missing, bent, or broken. Report loose or missing bolts, nuts, and screws to Unit maintenance.

**Welds.** Inspect for gaps where parts are welded together. Check for loose or chipped paint, rust, and cracks. Report bad welds to Unit maintenance.

**Wiring Harness, Wires, and Connectors.** Inspect for cracked or broken wiring harness insulation, bare wires, and loose or broken connectors. Report loose connections and faulty wiring to Unit maintenance.

**Hydraulic Brake Lines and Fittings.** Inspect for wear, damage, and leaks. Make sure fittings are tight. Report any damage, leaks, or loose fittings to Unit maintenance.

c. Check to see that components are adequately lubricated in accordance with Appendix I.

---

**2-7. SPECIFIC PMCS PROCEDURES.**


---

a. Operator/Crew PMCS procedures are provided in Table 2-1. Always perform PMCS procedures in the order listed. Once the procedures become routine, problems can be easily recognized.

b. Before performing PMCS, read all the checks required for the applicable interval and prepare all the tools needed for the task. Have several clean rags (Item 13, Appendix F) ready for use. Perform ALL inspections at the applicable intervals.

c. If any problems are discovered through PMCS, perform the appropriate troubleshooting task as described in Chapter 3. If any component or system is not serviceable, or if a given service does not correct the problem, notify your supervisor.

d. Explanations of the column headings in Table 2-1 are as follows:

**Item No.** The item number column of your PMCS table is to be used for reference. When completing DA Form 2404, include the item number for the check/service indicating a fault. Item numbers also appear in the order that you must do checks and services for the interval listed.

**Interval** This column of your PMCS table tells you when to do a certain check or service.

**Item To Be Inspected** This column names the item to be checked or serviced.

---

**2-7. SPECIFIC PMCS PROCEDURES (continued).**

---

**Procedure** This column tells you how to do the required checks and services. Follow these instructions carefully. If tools are not available or if the procedure says to, have Unit maintenance do the work.

**NOTE**

The term "mission capable" refers to equipment being on hand and able to perform its combat mission (refer to AR 700-138).

**Not Fully Mission Capable If:** This column explains when and why your equipment cannot be used.

---

**2-8. LEAKAGE DEFINITIONS.**

---

- a. It is important to know how fluid leakage affects the status of the trailer. The following are types/classes of leakage an operator must know to determine if the trailer is mission capable. Learn these leakage definitions. When in doubt, notify your supervisor.

Class I Seepage of fluid (as indicated by wetness or discoloration) not great enough to form drops.

Class II Leakage of fluid great enough to form drops, but not great enough to cause drops to drip from item being inspected.

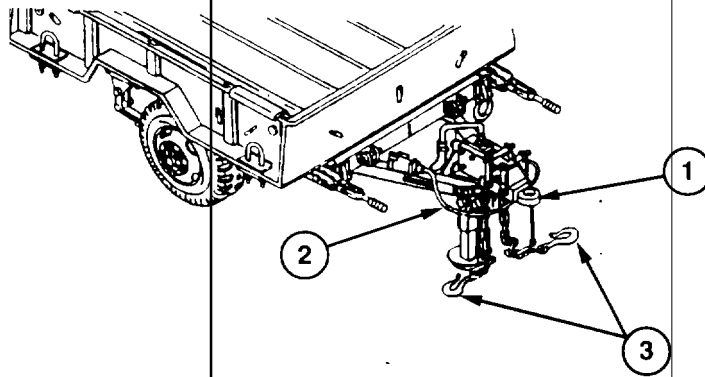
Class III Leakage of fluid great enough to form drops that fall from the item being inspected.

**CAUTION**

- Equipment operation is allowable with minor leakages (Class I or II). Of course, you must consider the fluid capacity in the item/system being checked/inspected. When in doubt, notify your supervisor. When operating with Class I or Class II leaks, continue to check fluid levels as required in your PMCS.
  - Class III leaks should be reported immediately to your supervisor or Unit maintenance.
- b. Equipment operation is allowed with minor (Class I or II) leakage. Fluid levels in an item/system affected with such leakage must be checked more frequently than required in PMCS. When in doubt, notify your supervisor.
- c. Report Class III leaks IMMEDIATELY to your supervisor or Unit maintenance.

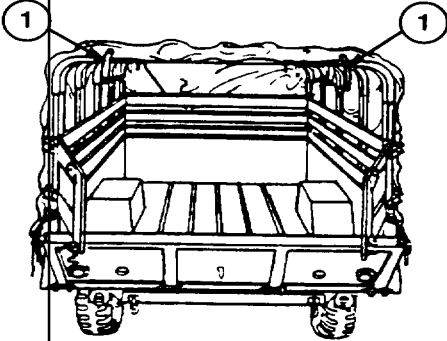
**Table 2-1. OPERATOR/CREW PREVENTIVE MAINTENANCE CHECKS AND SERVICES (PMCS)  
FOR THE M101 AND M116 SERIES TRAILERS**

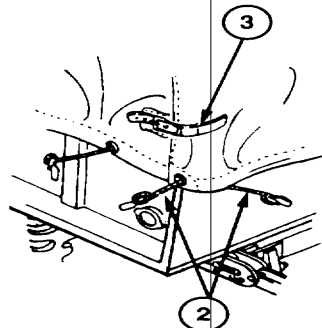
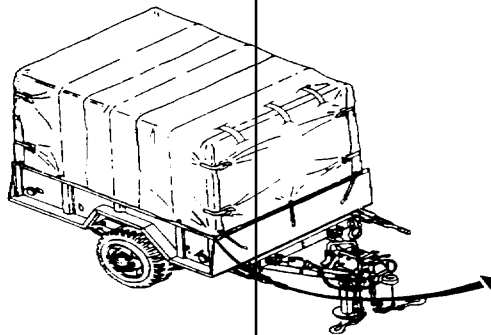
Item No.	Interval	Item to be inspected	Procedure	Not Fully Mission Capable If:
1	Before	Wheel and Tire Assembly	<p><b>NOTE</b></p> <p>Perform <i>Weekly</i> as well as <i>Before</i> PMCS if you are the assigned operator but have not operated the trailer since the last <i>Weekly</i> PMCS, or if you are operating the trailer for the first time.</p> <p><b>NOTE</b></p> <p>Lug nuts are turned clockwise to tighten and counterclockwise to loosen.</p> <p>a. Check wheels for damage and loose or missing lug nuts.</p> <p>b. Check tires for cuts, foreign objects, or unusual tread wear. Remove any stones from between treads.</p>	<p>a. One wheel is damaged. One lug nut is loose or missing.</p> <p>b. One tire is flat, missing, or unserviceable.</p>
2	Before	Drawbar Coupler, Intervehicular Cable, and Safety Chains	<p>a. Check drawbar coupler (1) for secure mounting and obvious damage.</p> <p>b. Check intervehicular cable (2) for cuts and breaks.</p> <p>c. Check safety chains (3) for secure mounting and obvious damage.</p>	<p>a. Drawbar coupler is loose or bent.</p> <p>c. Safety chains are missing or unsecured.</p>





**Table 2-1. OPERATOR/CREW PREVENTIVE MAINTENANCE CHECKS AND SERVICES (PMCS)  
FOR THE M101 AND M116 SERIES TRAILERS (continued)**

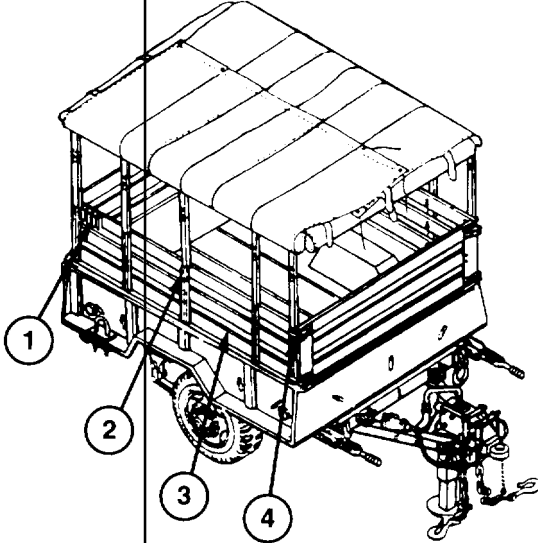
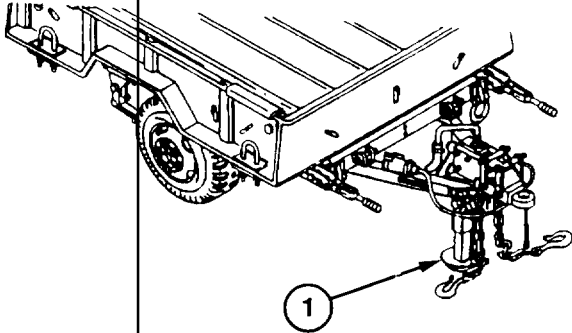
Item No.	Interval	Item to be inspected	Procedure	Not Fully Mission Capable If:
3	Before	Brake System	a. Test brake system by coupling trailer to towing vehicle (para 2-13).  b. Check for brake fluid leakage from master cylinder, hydraulic brake tube assemblies, hydraulic brake hose, and fittings.	a. Service brakes fail to operate.  b. Any leaks are found.
4	Before	Handbrakes	With trailer coupled to towing vehicle, apply handbrakes (para 2-10). Move trailer slightly to see if handbrakes hold the wheels.	
5	Before	Canvas Cover Assembly (M101A2 and M101A3)	a. Check for missing or unserviceable tiedown straps and snap fasteners (1).    b. Check for missing or unserviceable ropes (2).  c. Check for missing or unserviceable straps and buckles (3).  d. Check for ripped seams and tears.	



**Table 2-1. OPERATOR/CREW PREVENTIVE MAINTENANCE CHECKS AND SERVICES (PMCS)  
FOR THE M101 AND M116 SERIES TRAILERS (continued)**

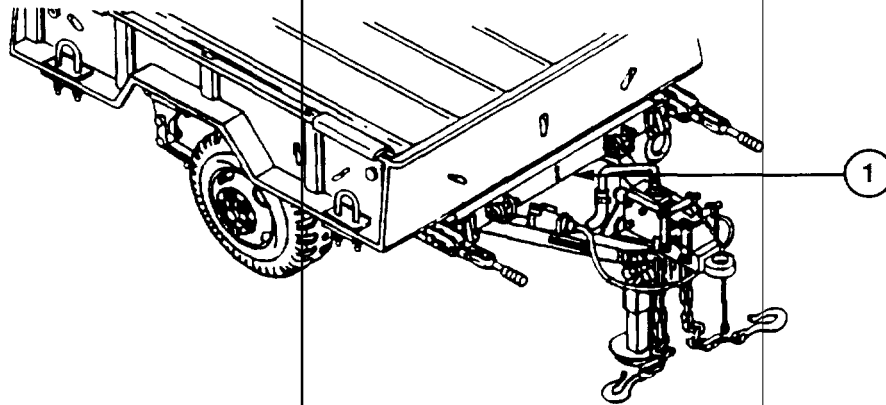
Item No.	Interval	Item to be inspected	Procedure	Not Fully Mission Capable If:
6	Before	Tailgate Assembly (M101A2 and M101A3)	a. Check for unserviceable slats (1). b. Check for missing or unserviceable strap hinge assemblies (2). c. Check for missing or unserviceable strap latch assemblies (3).	
7	Before	Front Rack Assembly (M101A2 and M101A3)	a. Check for unserviceable slats (1). b. Check for missing or unserviceable strap hinge assemblies (2).	
8	Before	Bow Assembly (M101A2 and M101A3)	Inspect for unserviceable bow assemblies (4)	

**Table 2-1. OPERATOR/CREW PREVENTIVE MAINTENANCE CHECKS AND SERVICES (PMCS)  
FOR THE M101 AND M116 SERIES TRAILERS (continued)**

Item No.	Interval	Item to be inspected	Procedure	Not Fully Mission Capable If:
9	Before	Side Rack Assembly (M101A2 and M101A3)	<p>a. Check for missing or unserviceable bow clips (1).</p> <p>b. Check for unserviceable stakes (2).</p> <p>c. Check for unserviceable slats (3).</p> <p>d. Check for missing or unserviceable strap hinge assemblies (4).</p> 	
10	During Leg	Front Support	<p>With trailer coupled to towing vehicle, check front support leg (1) for ease of operation.</p>  <p>2-9</p>	Front support leg will not secure in stowed position or will not support trailer.

**Table 2-1. OPERATOR/CREW PREVENTIVE MAINTENANCE CHECKS AND SERVICES (PMCS)  
FOR THE M101 AND M116 SERIES TRAILERS (continued)**

Item No.	Interval	Item to be inspected	Procedure	Not Fully Mission Capable If:
11	During	Stoplight-Taillights	<p>NOTE</p> <p>An assistant is required while checking stoplight-taillights.</p> <p>a. Connect intervehicular cable to towing vehicle (para 2-13).</p> <p>b. Operate towing vehicle light switch through all settings and check stoplight-taillights.</p>	
12	During	Trailer Operation	<p>a. Be alert for any unusual noise while towing trailer. Stop and investigate any unusual noises.</p> <p>b. Make sure trailer is tracking correctly behind towing vehicle, with no side pull.</p>	
13	Weekly	Wheel and Tire Assembly	Check for proper tire pressure when tires are cool (para 1-15).	One tire is flat, missing, or unserviceable.
14	Weekly	Reflectors	On cargo trailers, check for damage and presence of reflectors.	
15	Monthly	Frame	When trailer is loaded, inspect entire Chassis frame (1) for damage, cracks, and broken welds.	Frame is broken or cracked.



**Section III. OPERATION UNDER USUAL CONDITIONS**

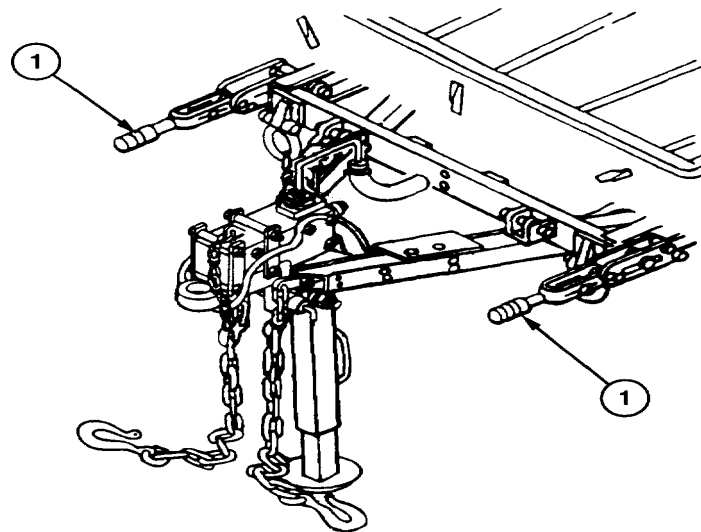
Paragraph Number		Page Paragraph
2-9	General .....	2-11
2-10	Operating Handbrakes .....	2-11
2-11	Installing Rack, Tailgate, and Canvas Cover Assemblies (M101A2 and M101A3) .....	2-12
2-12	Loading the Trailer.....	2-15
2-13	Coupling Trailer to Towing Vehicle .....	2-16
2-14	Towing Instructions .....	2-19
2-15	Uncoupling Trailer from Towing Vehicle .....	2-21
2-16	Removing Canvas Cover, Tailgate, and Rack Assemblies (M101A2 and M101A3) .....	2-23

**2-9. GENERAL.**

- a. This section contains instructions for safely operating the M101 and M116 Series trailers under usual conditions. Unusual operating conditions are defined and described in Section IV of this chapter.
- b. Before operating a trailer, make sure Unit maintenance services the vehicle.
- c. Perform all *Before* PMCS listed in Table 2-1 before operating the trailer.
- d. Before coupling and uncoupling the trailer, review all towing instructions in the operator's manual for the towing vehicle.

**2-10. OPERATING HANDBRAKES.**

- a. Pull handbrake levers (1) forward and down to apply handbrakes.
- b. Push handbrake levers (1) to an upright position to release handbrakes.



2-11

**2-11. INSTALLING RACK, TAILGATE, AND CANVAS COVER ASSEMBLIES (M101A2 AND M101A3).**

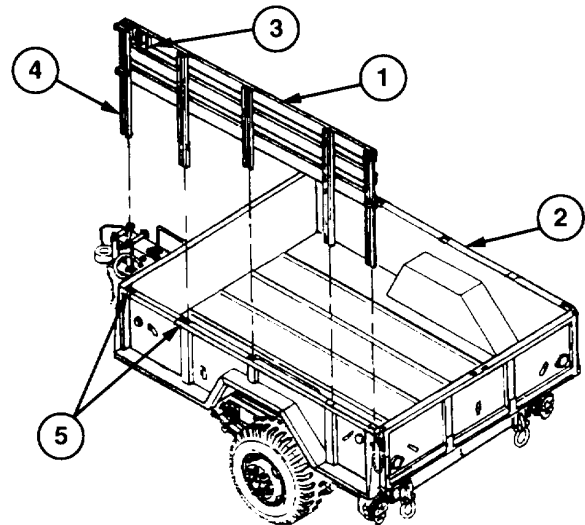
**WARNING**

Side rack assembly is heavy and awkward to handle. To prevent injury to personnel, use extreme caution and get assistance when handling.

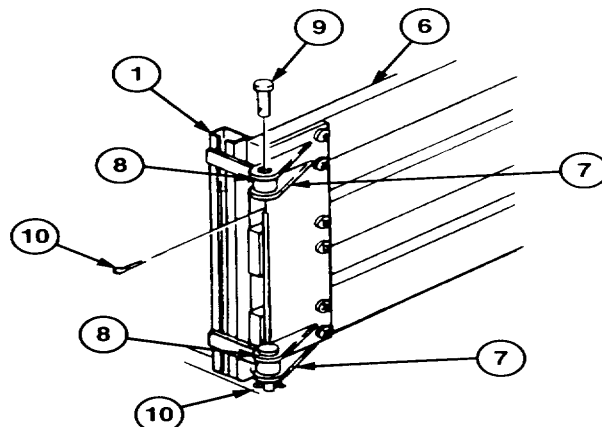
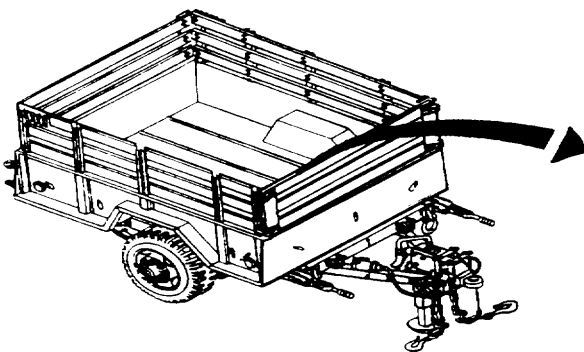
**NOTE**

Two persons are required when performing this task.

- a. Apply handbrakes (para 2-10).
- b. Lift road-side side rack assembly (1) into position above cargo body (2), with bow clips (3) toward front of trailer.
- c. Align five stakes (4) with five stake pockets (5) in cargo body (2). Push stakes (4) evenly into stake pockets (5) until road-side side rack assembly (1) is fully installed in cargo body (2).
- d. Repeat steps b and c to install curb-side side rack assembly (1).
- e. Position front rack assembly (6) between road-side and curb-side side rack assemblies (1).

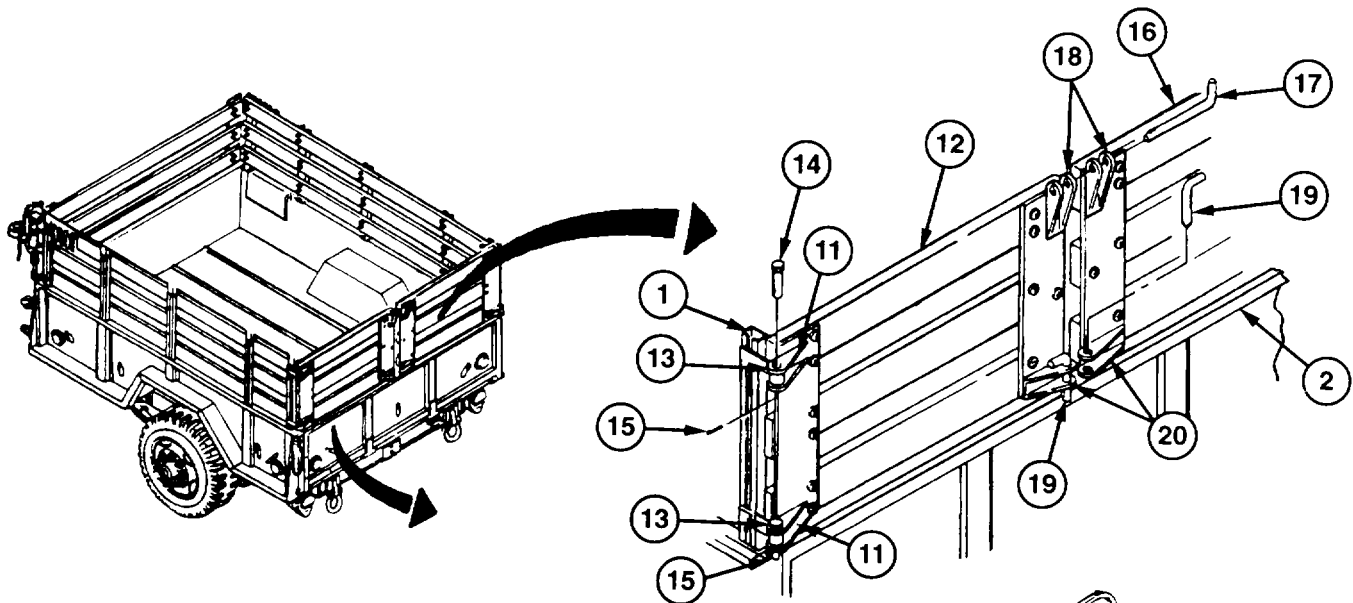


- f. At road-side corner, align two strap hinge assemblies (7) on front rack assembly (6) with two hinges (8) on road-side side rack assembly (1).
- g. Install two straight headed pins (9), with heads facing up, in two strap hinge assemblies (7) and hinges (8). Install two cotter pins (10) in straight headed pins (9).
- h. At curb-side corner, repeat steps f and g to install front rack assembly (6) on curb-side side rack assembly (1).

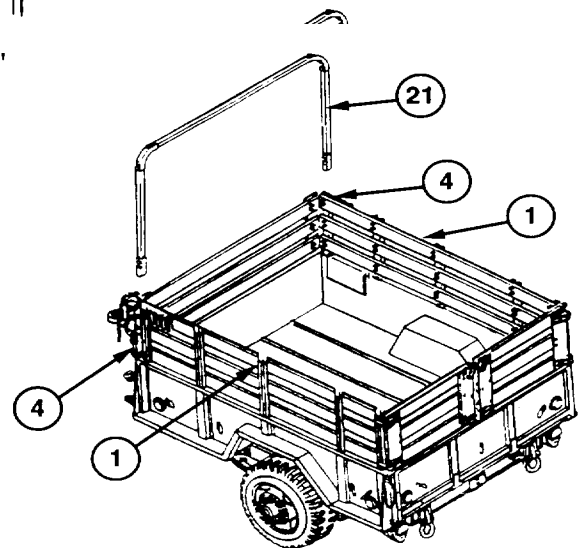


**2-11. INSTALLING RACK, TAILGATE, AND CANVAS COVER ASSEMBLIES (M101 A2 AND M101A3) (continued).**

- i. At rear of trailer, align two strap hinge assemblies (11) on tailgate assembly (12) with two hinges (13) on road-side side rack assembly (1).
- j. Install two straight headed pins (14), with heads facing up, in two strap hinge assemblies (11) and hinges (13). Install two cotter pins (15) in two straight-headed pins (14).
- k. At curb side, repeat steps i and j to install curb-side tailgate assembly (16) on curb-side side rack assembly (1).
- l. Close both tailgate assemblies (12 and 16).
- m. Install connecting link (17) in two top strap latch assemblies (18) of both tailgate assemblies (12 and 16).
- n. Install two connecting links (19) in two bottom strap latch assemblies (20) on both tailgate assemblies (12 and 16) and two holes in cargo body (2).



- o. Align one of five bow assemblies (21) with two stakes (4) in both side rack assemblies (1). Push bow assembly (21) evenly into stakes (4) until fully installed in side rack assemblies (1).
- p. Repeat step o to install remaining four bow assemblies (21).

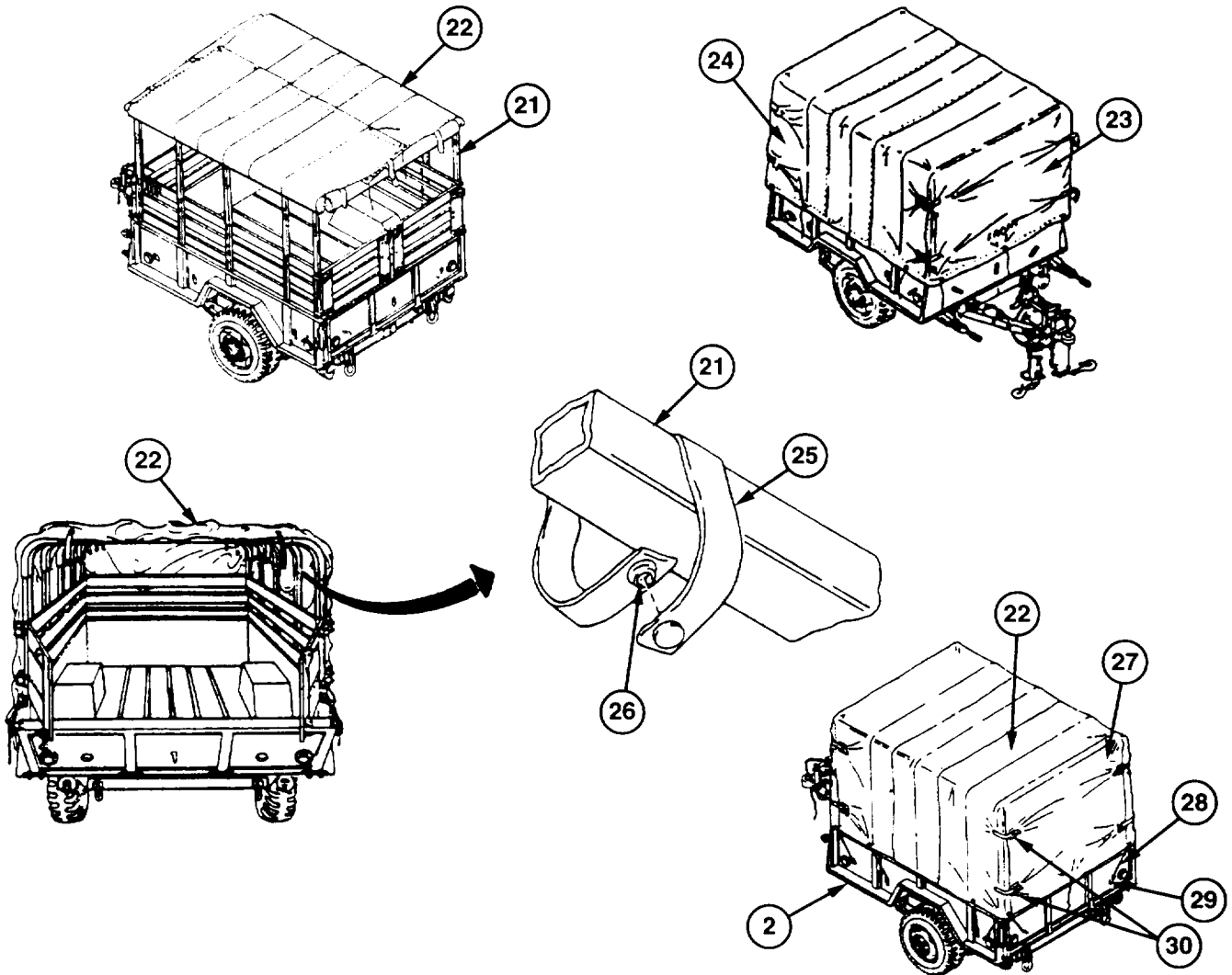


**2-11. INSTALLING RACK, TAILGATE, AND CANVAS COVER ASSEMBLIES (M101A2 AND M101A3) (continued).**

**NOTE**

Canvas cover assembly should be positioned so that the side marked "FRONT" faces the front of the trailer.

- q. Spread canvas cover assembly (22) over five bow assemblies (21).
- r. Unfold front curtain (23) and two side curtains (24).
- s. From inside, attach top of canvas cover assembly (22) to five bow assemblies (21) by securing 10 tiedown straps (25) using 10 snap fasteners (26).
- t. Unfold back curtain (27).
- u. Attach 14 ropes (28) to 14 cargo hooks (29) on cargo body (2). Fasten eight straps (30) on canvas cover assembly (22).





**2-12. LOADING THE TRAILER.****WARNING**

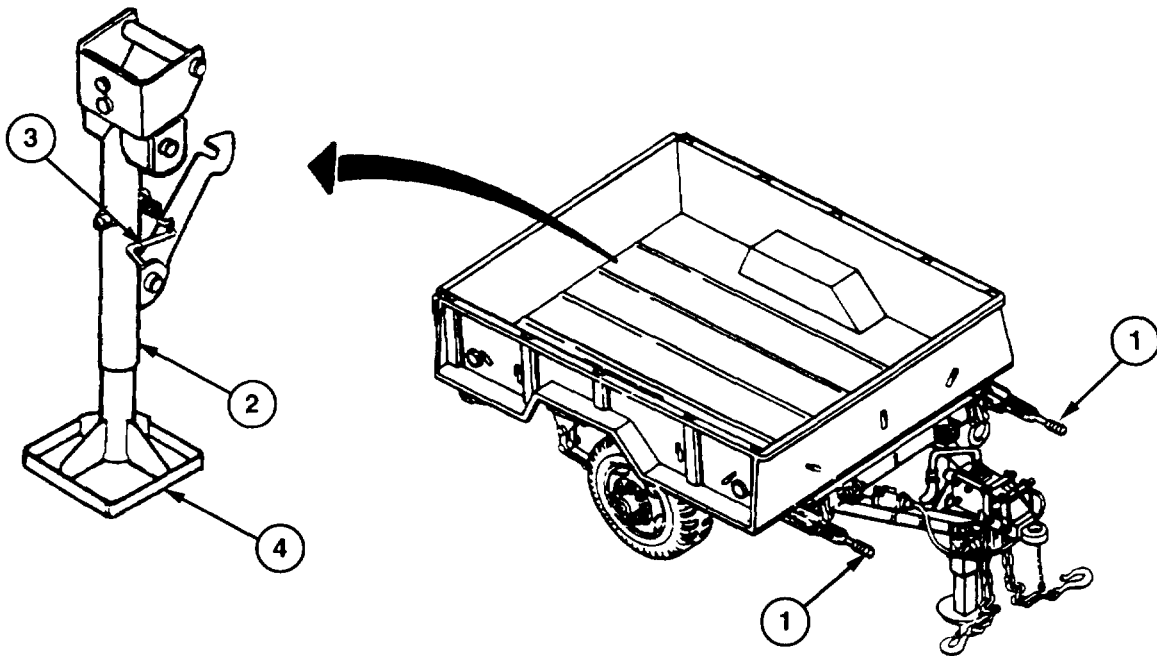
If trailer is not coupled to towing vehicle, make sure handbrakes are applied and wheels are chocked securely. Failure to follow this warning may cause trailer to roll, resulting in serious injury or death to personnel or damage to equipment.

- a. Operate handbrake levers (1) to apply handbrakes (para 2-10).

**WARNING**

Rear stabilizer must be used if trailer is carrying generator sets. Failure to follow this warning may cause trailer to tip, resulting in serious injury to personnel or damage to equipment.

- b. If equipped with rear stabilizer (2), pull out on release handle (3) and lower rear stabilizer (2). Turn foot assembly (4) until it firmly contacts ground.

**WARNING**

Make sure weight of load is evenly distributed. Too much weight at the front will make trailer difficult to lift. Too much weight at the rear will cause trailer to tip backward. Serious injury to personnel or damage to equipment may result.

- c. Distribute load evenly over trailer. Do not exceed maximum allowable payload (para 1-15).

**2-13. COUPLING TRAILER TO TOWING VEHICLE.****NOTE**

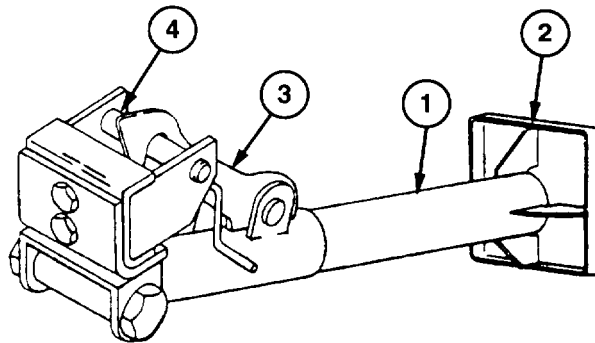
Make sure towing vehicle and trailer are on level ground before coupling.

- a. Apply handbrakes (para 2-10).

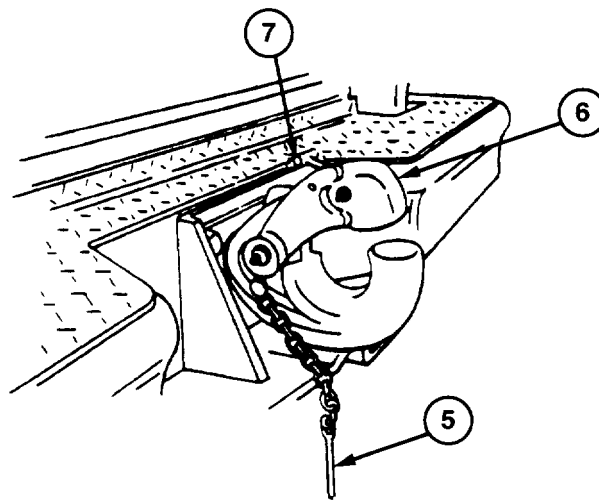
**WARNING**

Make sure weight of trailer is on front support leg before raising rear stabilizer. Failure to follow this warning may cause trailer to tip, resulting in serious injury to personnel or damage to equipment.

- b. If equipped with rear stabilizer (1), turn foot assembly (2) as far as it will go into rear stabilizer (1). Swing rear stabilizer (1) up until latch hook (3) hooks onto up-latch pin (4).



- c. Remove safety pin (5) from pintle hook (6) of towing vehicle.
- d. Pull up on locking latch (7) to open pintle hook (6).



**2-13. COUPLING TRAILER TO TOWING VEHICLE (continued).****WARNING**

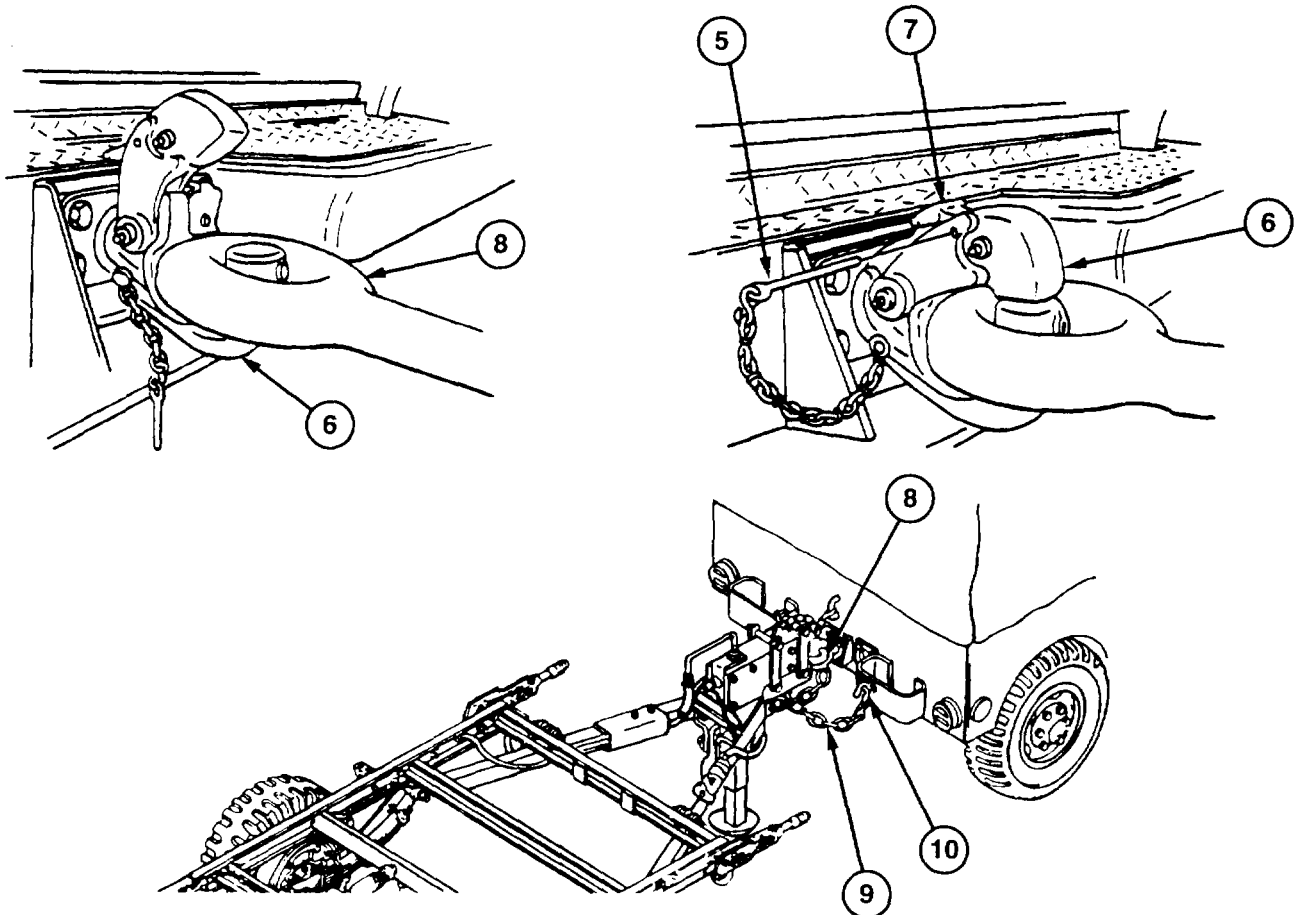
All personnel must stand clear of towing vehicle and trailer during coupling operation. Failure to follow this warning may result in serious injury or death to personnel.

- e. Back towing vehicle in front of drawbar coupler (8).

**WARNING**

Drawbar is heavy (280 lb [127 kg] loaded tongue weight). Four or more persons are needed to lift drawbar. Failure to follow this warning may result in injury to personnel.

- f. Use handcrank to adjust height of drawbar coupler (8). Place drawbar coupler (8) in pintle hook (6).
- g. Close pintle hook (6). Check to see that locking latch (7) is locked by pulling up on pintle hook (6). Pintle hook (6) should not come up. Install safety pin (5) in pintle hook (6).
- h. Cross two safety chains (9) under drawbar coupler (8) and hook to two towing vehicle eyebolts (10).



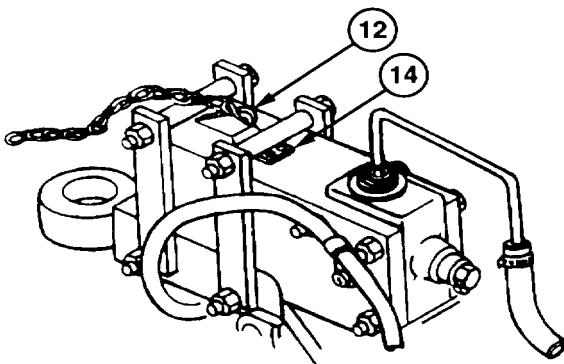
**2-13. COUPLING TRAILER TO TOWING VEHICLE (continued).**

- i. Attach breakaway chain (11) to towing vehicle. Make sure there is enough slack in breakaway chain (11) to allow trailer to make full turns.

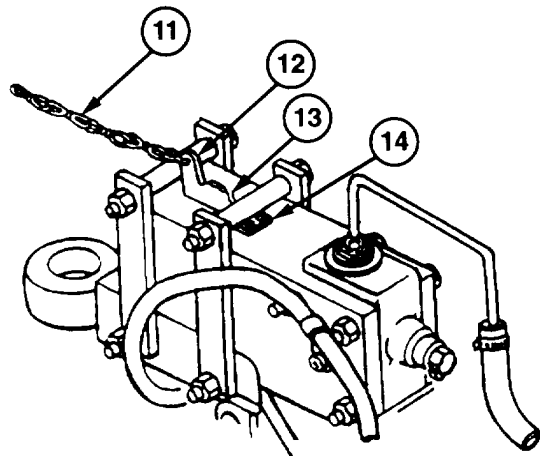
**CAUTION**

Make sure breakaway lever (12) is fully released. If breakaway lever is not fully released trailer brakes will drag, heat up, and burn out.

- j. Make sure breakaway lever (12) is pushed all the way back toward trailer and that ratchet teeth (13) are not engaged in leaf spring (14). If ratchet teeth (13) are engaged in leaf spring (14), lift leaf spring (14) and push breakaway lever (12) all the way back toward trailer.

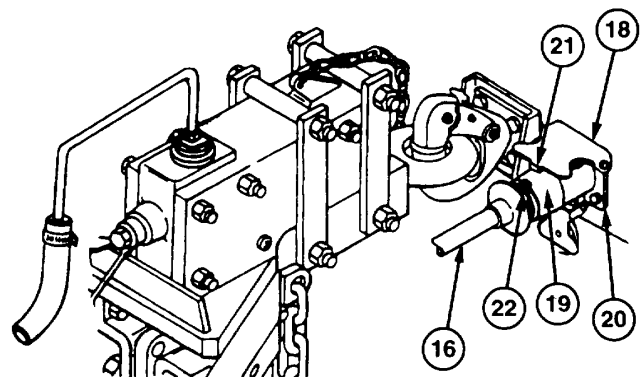
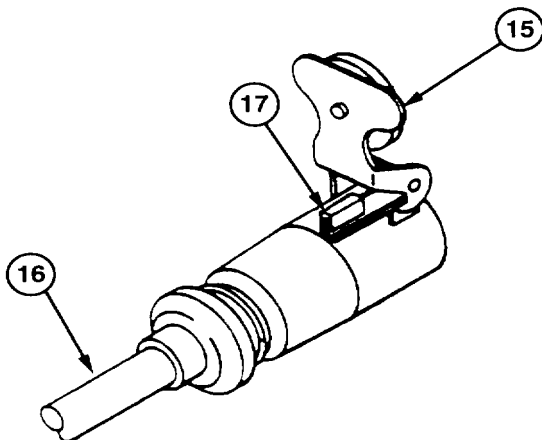


**BRAKES RELEASED**



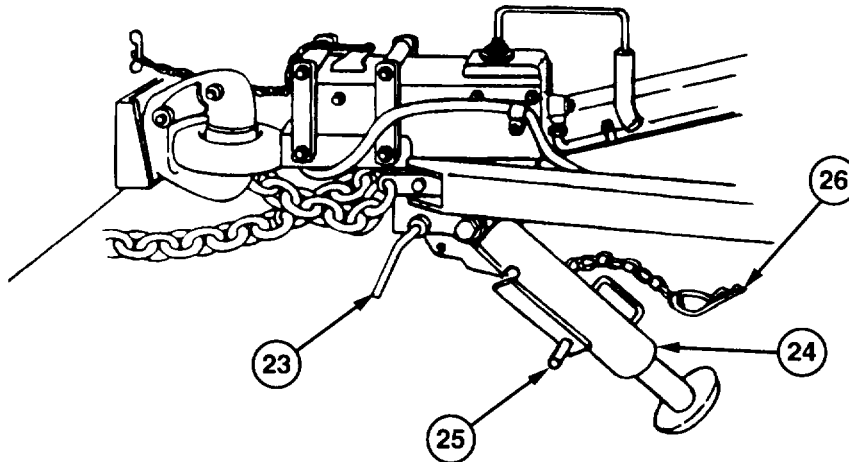
**BRAKES APPLIED**

- k. Open latch cover (15) of intervehicular cable (16) and push latch (17) to hold latch cover (15) open.
- l. Lift receptacle cover (18) of towing vehicle. Push plug (19) of intervehicular cable (16) all the way into towing vehicle receptacle (20). Release receptacle cover (18). Make sure tab (21) rests in slot (22).



**2-13. COUPLING TRAILER TO TOWING VEHICLE (continued).**

- m. Pull out on plunger (23) and raise front support leg (24). Lock front support leg (24) in raised position by pushing in plunger (23) all the way.
- n. Stow handcrank (25) on front support leg (24) with chain and cotter pin (26).
- o. Release handbrakes (para 2-10).

**2-14. TOWING INSTRUCTIONS.****WARNING**

Do not stand between towing vehicle and trailer when backing towing vehicle. Serious injury can result if personnel are caught between vehicles.

**NOTE**

Refer to FM 21-305 for further information on proper towing practices.

- a. DRIVING

**CAUTION**

Sudden stops may cause drawbar to bend or buckle and may cause damage to hydraulic brake actuator assembly.

1. When trailer is coupled, always start and stop towing vehicle slowly and gradually. Do this whether or not trailer is loaded.
2. Sudden and fast acceleration will cause hydraulic brakes to apply.
3. Never exceed maximum speed of 50 miles per hour (80 kph) highway and 6 miles per hour (10 kph) cross-country.

---

**2-14. TOWING INSTRUCTIONS (continued).**

---

4. When driving towing vehicle and trailer, overall length of unit must be kept in mind when turning and passing other vehicles. Because unit is hinged in the middle, turning and backing are also affected. Heavier payloads will increase stopping distance and decrease off-road maneuverability.

**b. TURNING****CAUTION**

Tight turns may cause damage to hydraulic brake actuator assembly.

1. When turning corners, allow for the fact that trailer wheels turn inside the turning radius of towing vehicle.
2. To make a right turn at an intersection, drive towing vehicle partway into intersection, then cut sharply to the right. This will allow for turning radius of trailer keep trailer wheels off the curb.

**c. BACKING****CAUTION**

**Jackknifing when backing may cause damage to hydraulic brake actuator assembly.**

1. Always back towing vehicle slowly and gradually.
2. Whenever possible, have an assistant driver or another person act as a ground guide.
3. Adjust all towing vehicle rearview mirrors before backing.
4. When backing, rear of trailer will move in opposite direction in which towing vehicle is turned. When towing vehicle is turned to the right, rear of trailer will go left. When towing vehicle has turned and backing in a straight line is required, turn towing vehicle in direction trailer is moving. This will slowly bring towing vehicle and trailer into a straight line.

**CAUTION**

**Sudden stops may cause drawbar to bend or buckle and may cause damage to hydraulic brake actuator assembly.**

**d. STOPPING**

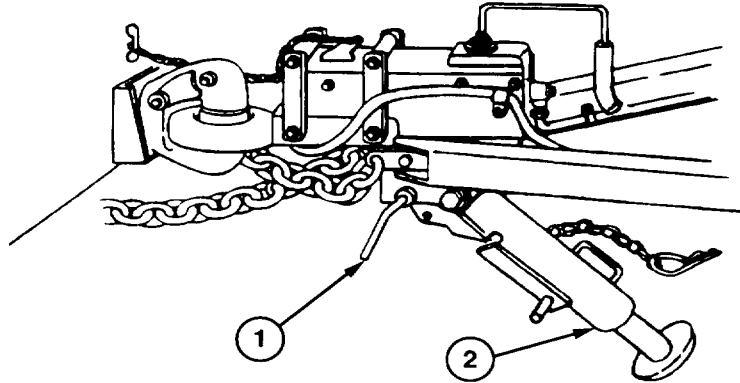
Always stop towing vehicle by applying brakes gradually and smoothly. Do this whether or not trailer is loaded.

**e. PARKING**

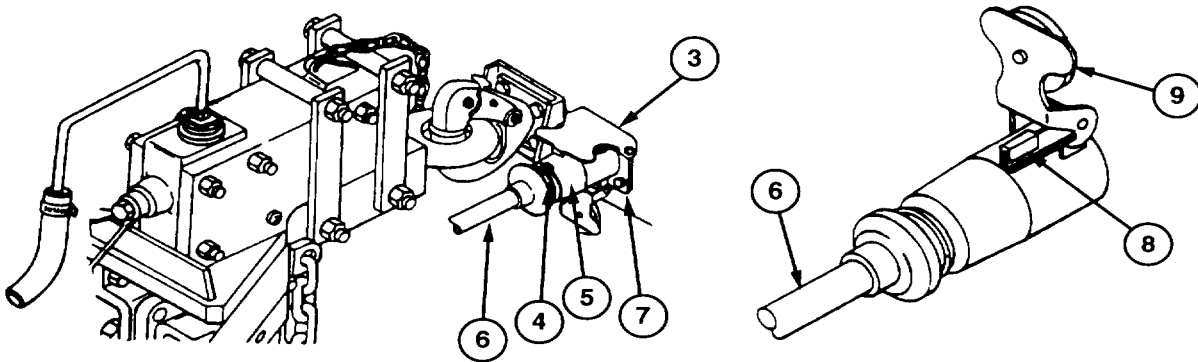
1. When towing vehicle and trailer are to be left unattended, set towing vehicle parking brakes, turn off engine, and set wheel chocks.
2. Apply handbrakes (para 2-10).

**2-15. UNCOUPLING TRAILER FROM TOWING VEHICLE.**

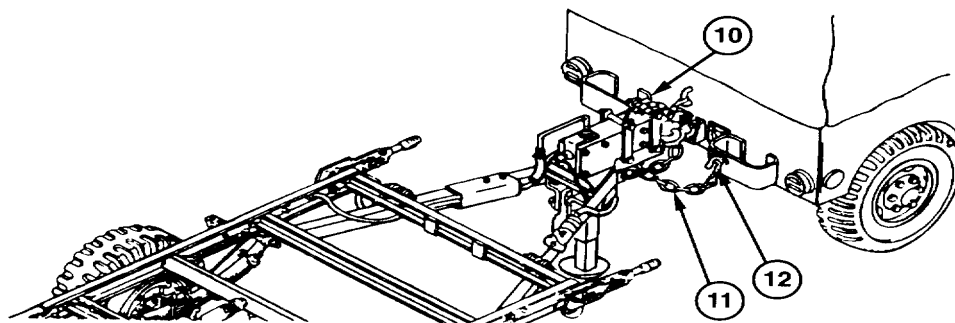
- a. Apply handbrakes (para 2-10).
- b. Pull out on plunger (1), and lower front support leg (2). Lock front support leg (2) in lowered position by pushing in plunger (1) all the way.



- c. Lift receptacle cover (3) of towing vehicle from slot (4), and disconnect plug (5) of intervehicular cable (6) from towing vehicle receptacle (7).
- d. Pull back latch (8). Latch cover (9) of intervehicular cable (6) is spring-loaded to close.



- e. Remove breakaway chain (10) from towing vehicle. Remove two safety chains (11) from two towing vehicle eyebolts (12).



**2-15. UNCOUPLING TRAILER FROM TOWING VEHICLE (continued).****WARNING**

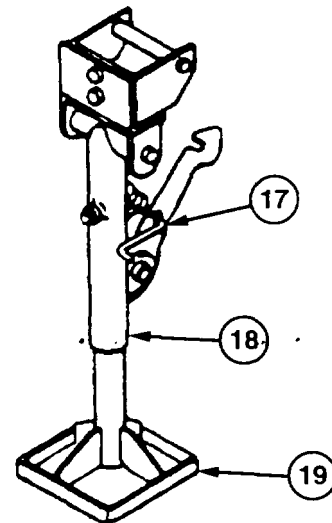
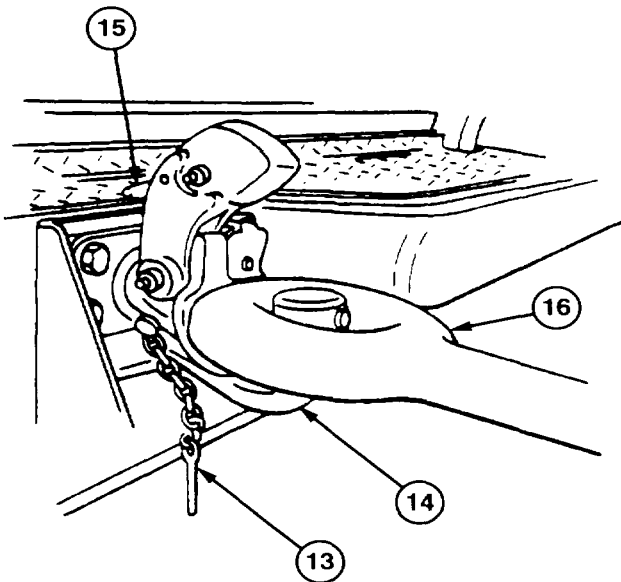
If load has shifted, make sure it is evenly distributed before removing drawbar coupler from pintle hook. Failure to follow this warning may cause trailer to tip, resulting in injury to personnel or damage to equipment.

- f. Remove safety pin (13) from pintle hook (14).
- g. Pull up on locking latch (15) and open pintle hook (14).

**WARNING**

Drawbar is heavy (280 lb [127 kg] loaded tongue weight). Four or more persons are needed to lift drawbar. Failure to follow this warning may result in injury to personnel.

- h. Use handcrank to adjust height of drawbar coupler (16). Remove drawbar coupler (16) from pintle hook (14).
- i. Close pintle hook (14). Pull up on pintle hook (14) to ensure that locking latch (15) is engaged. Install safety pin (13) in pintle hook (14).
- j. Pull out on release handle (17), and lower rear stabilizer (18). Turn foot assembly (19) until it firmly contacts ground.



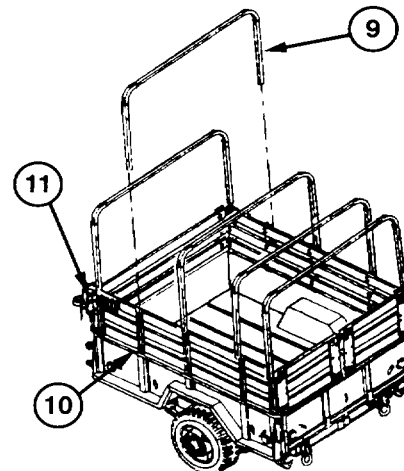
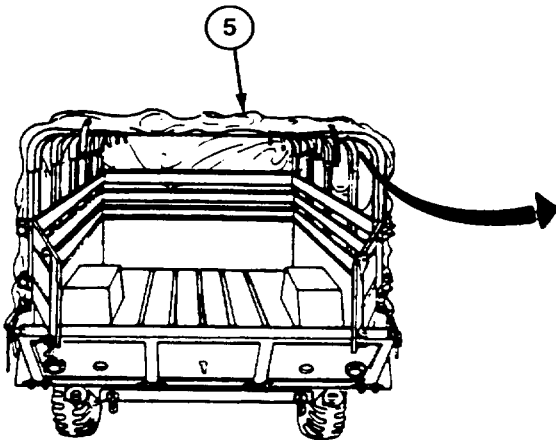
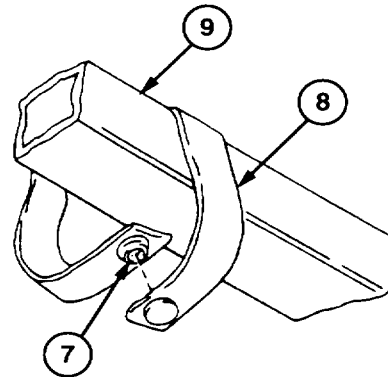
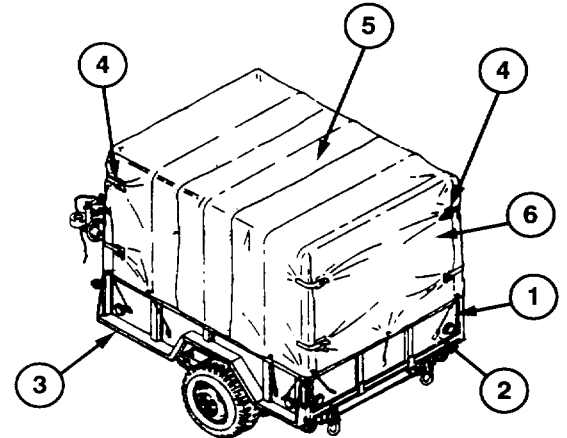


**2-16. REMOVING CANVAS COVER, TAILGATE, AND RACK ASSEMBLIES (M101A2 AND M101A3).**

**NOTE**

Assistance is required for performing this task.

- a. Apply handbrakes (para 2-10).
- b. Remove 14 ropes (1) from 14 cargo hooks (2) on cargo body (3).
- c. Unfasten eight straps (4) on canvas cover assembly (5).
- d. Fold back curtain (6) over top of canvas cover assembly (5).
- e. From Inside trailer, unsnap 10 snap fasteners (7) and remove 10 tiedown straps (8) from five bow assemblies (9).
- f. Remove canvas cover assembly (5) from five bow assemblies (9). Fold canvas cover assembly (5) and stow.



9. Remove five bow assemblies (9) from 10 stakes (10).

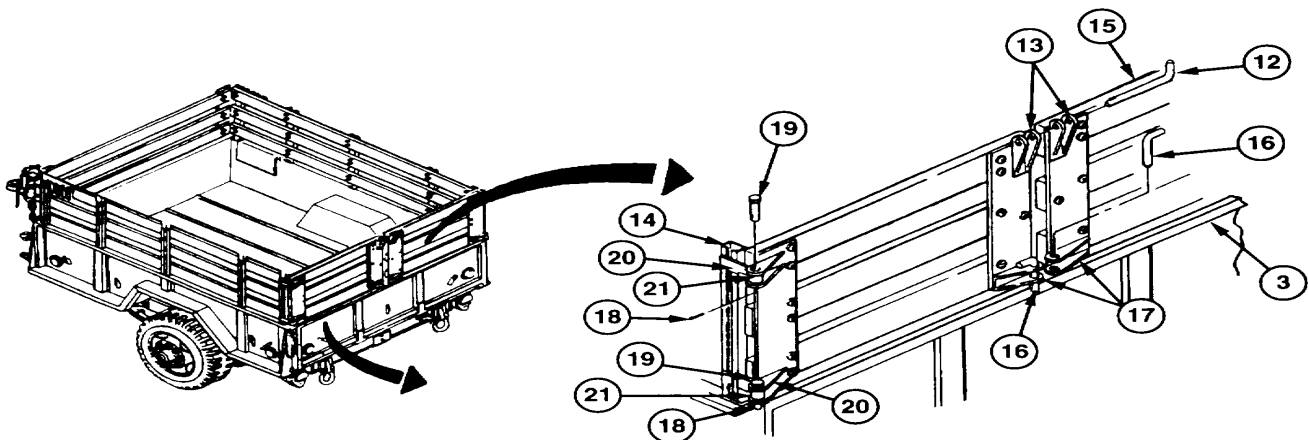
**NOTE**

Skip step h if rack and tailgate assemblies are being removed. Bow assemblies are stowed in bow clips only if rack and tailgate assemblies are not removed.

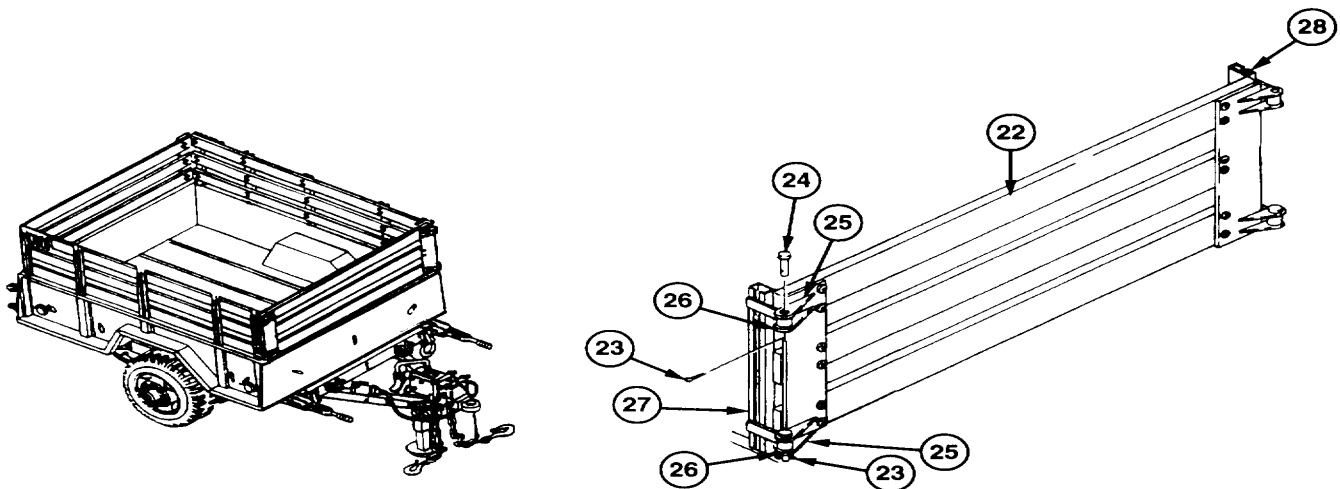
- h. Stow five bow assemblies (9) in 10 bow clips (11).

2-16. REMOVING CANVAS COVER, TAILGATE, AND RACK ASSEMBLIES (M101A2 AND M101A3) (continued).

- i. Remove connecting link (12) from two top strap latch assemblies (13) of road-side and curb-side tailgate assemblies (14 and 15).
- j. Remove two connecting links (16) from two bottom strap latch assemblies (17) and holes in cargo body (3).
- k. At road-side tailgate assembly (14), remove two cotter pins (18) and headed straight pins (19) from two strap hinge assemblies (20) and hinges (21). Remove road-side tailgate assembly (14) from curb-side tailgate assembly (15).
- l. At curb side, repeat step k to remove curb-side tailgate assembly (15).



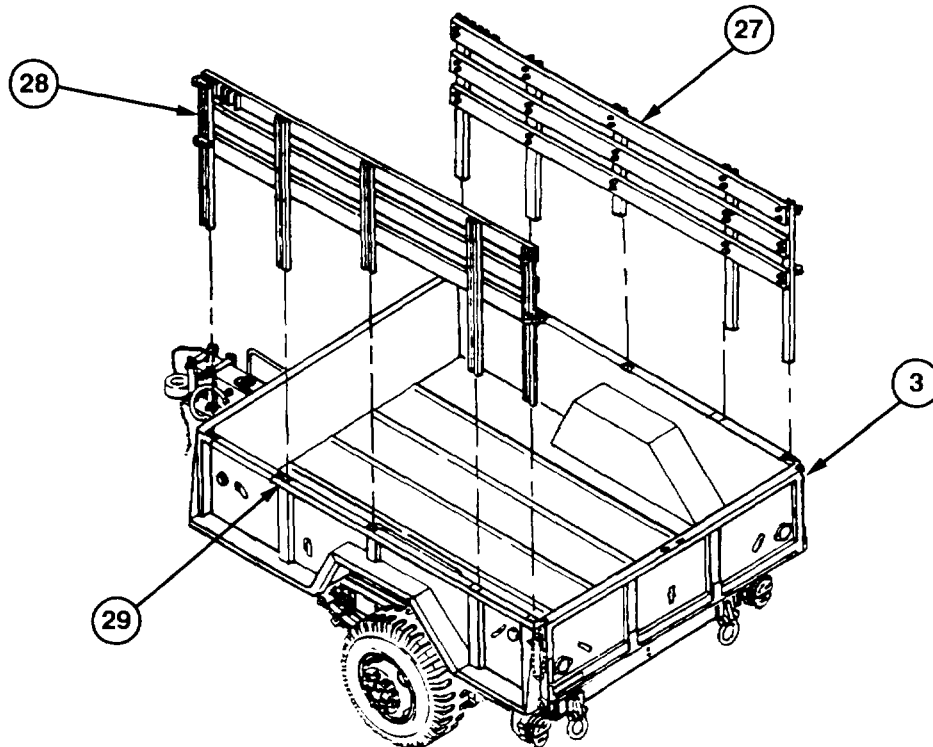
- m. At road-side front rack assembly (22), remove two cotter pins (23) and headed straight pins (24) from two strap hinge assemblies (25) and hinges (26) on road-side side rack assembly (27).
- n. Repeat step m at curb-side front rack assembly (22).
- o. Remove front rack assembly (22) from road-side and curb-side rack assemblies (27 and 28).



**2-16. REMOVING CANVAS COVER, TAILGATE, AND RACK ASSEMBLIES (M101A2 AND M101A3) (continued).****WARNING**

Side rack assembly is heavy and awkward to handle. To prevent injury to personnel, use extreme caution and get assistance when handling.

- p. Lift road-side side rack assembly (27) from five stake pockets (29) in cargo body (3).
- q. Repeat step p for curb-side side rack assembly (28).



**Section IV. OPERATION UNDER UNUSUAL CONDITIONS**

Paragraph Number	Paragraph Title	Page Number
2-17	General	2-26
2-18	Operation in Extreme Cold .....	2-26
2-19	Operation in Extreme Heat .....	2-26
2-20	Operation in High Humidity and Saltwater Areas .....	2-27
2-21	Operation in Mud and Snow .....	2-27
2-22	Operation in Dusty or Sandy Areas .....	2-27
2-23	Operation in Rocky Terrain.....	2-27
2-24	At Halt/Parking.....	2-28
2-25	Fording .....	2-28

**2-17. GENERAL.**

- a. This section contains instructions for safely operating the M101 and M116 Series trailers under unusual conditions.
- b. In addition to normal preventive maintenance, special care must be taken in regard to cleaning and lubrication to keep the trailers operational in extreme temperatures and humidity. Proper cleaning, lubrication, storage, and handling ensure proper operation and function and also guard against excessive wear.
- c. Chronic failure of materiel resulting from exposure to extreme conditions must be reported in accordance with DA Pam 738-750.

**2-18. OPERATION IN EXTREME COLD.**

- a. Refer to the lubrication instructions in Appendix I for proper lubricants to use in extreme cold weather conditions.
- b. Refer to FM 9-207 and FM 21-305 for special instructions on driving hazards that may be encountered during extreme cold weather conditions.
- c. Extreme cold can cause insulation material on electrical harnesses and wires to crack, causing short circuits. Other materials can become hard, brittle, and easily damaged or broken.
- d. Make sure tires are properly inflated (para 1-15). Tires may freeze to the ground or have flat spots if underinflated.
- e. Brakeshoes may freeze to the brakedrum and will require preheating to prevent damage (FM 9-207).

**2-19. OPERATION IN EXTREME HEAT.**

- a. Refer to Appendix I for proper lubrication during extreme heat conditions. Adequate lubrication is essential. Extreme heat will cause oil films to evaporate, resulting in inadequate lubrication.
- b. Keep tires covered from direct sunlight to prevent increases in air pressure and deterioration of rubber.

---

**2-20. OPERATION IN HIGH HUMIDITY AND SALTWATER AREAS.**

---

- a. Moist and salty areas can destroy the rust preventative qualities of oils and greases. When equipment is active, exposed surfaces should be cleaned and lubricated daily. Refer to Appendix I for proper lubrication in high humidity and saltwater areas.
- b. When equipment is inactive, unpainted parts should be coated with grease (Item 7, Appendix F). All covers and caps should be in place.

---

**2-21. OPERATION IN MUD AND SNOW.**

---

- a. After operation in mud or snow, have Unit maintenance pack wheel bearings as required (refer to Appendix I).
- b. Refer to FM 21-305 for special instructions on driving hazards in snow. For better traction, reduce air pressure to 25 psi (174 kPa).
- c. If one or more tires sink into mud or snow, it may be necessary to raise the tire and insert planking or matting beneath it.
- d. Immediately after operation in mud and snow, thoroughly clean, inspect, and lubricate if tactical situation permits. Refer to Appendix I for proper lubrication instructions.

---

**2-22. OPERATION IN DUSTY OR SANDY AREAS.**

---

- a. Inspect, clean, and lubricate frequently when operating in sandy or dusty areas. Refer to Appendix I for proper lubrication instructions.
- b. Make sure no dust or sand enters exposed mechanisms or lubrication fittings during inspections and repair operations. Cover exposed parts with tarpaulins or other suitable cover during disassembly and assembly.
- c. When beginning operation in dusty or sandy areas, remove lubricants from exposed components, such as landing gear, if tactical situation permits. Grease and oil will cause dust and sand to accumulate and act as an abrasive, which will cause rapid wear.
- d. Reduce tire pressure to 30 psi (207 kPa) for emergency use on beach or desert sand. Return tire pressure to normal after emergency operation (para 1-15).

---

**2-23. OPERATION IN ROCKY TERRAIN.**

---

Use extreme caution when operating in rocky terrain. Make sure tires are fully inflated to minimize damage to tires and tubes (para 1-15).

---

**2-24. AT HALT/PARKING.**

---

- a. For short shutdown periods, park in a sheltered spot out of the wind. For long shutdown periods, prepare a footing of planks or brush if high, dry ground is not available.
- b. Remove all buildup of ice and snow as soon as possible after shutdown.
- c. Cover trailer with canvas cover assembly or tarpaulin, keeping the ends of the canvas off the ground to prevent freezing.

---

**2-25. FORDING.**

---

- a. Refer to operating instructions in towing vehicle technical manual for information about fording operations.
- b. Fording depth of the M101 and M116 Series trailers is limited to 30 inches (76.2 cm).
- c. If tactical situation permits, perform the following services immediately after fording the trailer:

**WARNING**

Drycleaning solvent P-D-680 is toxic and flammable. Always wear protective goggles and gloves, and use only in a well-ventilated area. Avoid contact with skin, eyes, and clothes, and DO NOT breathe vapors. DO NOT use near open flame or excessive heat.

(1) Notify Unit maintenance to remove wheel and rim assemblies and clean them thoroughly with drycleaning solvent (Item 15, Appendix F). Dry all working components of handbrakes and wheel bearings. Lubricate handbrakes and underbody (Appendix I).

(2) Immersion in saltwater greatly increases rusting and corrosion, especially on unpainted surfaces. Remove all traces of saltwater and salt deposits from all areas of the trailer. Apply grease (Item 7, Appendix F) to exposed areas of trailer. Notify Unit maintenance that complete disassembly and assembly may be needed.

**CHAPTER 3  
OPERATOR/CREW MAINTENANCE INSTRUCTIONS**

**Section I. LUBRICATION INSTRUCTIONS**

---

**3-1. LUBRICATION INSTRUCTIONS.**

---

Lubrication instructions are in Appendix I of this manual. All lubrication instructions are mandatory.

**Section II. OPERATOR/CREW TROUBLESHOOTING PROCEDURES**

<b>Paragraph Number</b>	<b>Paragraph Title</b>	<b>Page Number</b>
3-2	General	3-2
3-3	Electrical Troubleshooting	3-2
3-4	Quick Guide to Troubleshooting	3-3
3-5	Troubleshooting Chart	3-4

---

**3-2. GENERAL.**

---

- a. This section provides information for identifying and correcting malfunctions that may develop while operating or maintaining your trailer.
- b. The Quick Guide to Troubleshooting (para 3-4) lists common symptoms you may find during operation or maintenance of your trailer or its components, and refers you to the Troubleshooting Chart (para 3-5) for the appropriate troubleshooting procedures. You should perform the tests/inspections and corrective actions in the order listed.
- c. If you are unsure of the location of an item mentioned in troubleshooting, refer to paragraph 1-12 or to the maintenance task where the item is replaced.
- d. Before performing troubleshooting, read and follow all safety instructions found in the warning summary at the beginning of this manual.
- e. This section cannot list all malfunctions that may occur, nor all tests or inspections and corrective actions. If a malfunction is not listed or is not corrected by the corrective actions listed, notify your supervisor or Unit maintenance.
- f. When troubleshooting a malfunction:
  - 1. Locate the symptom(s) in the Quick Guide to Troubleshooting (para 3-4) that best describes the malfunction.
  - 2. Turn to the page in the Troubleshooting Chart (para 3-5) where the troubleshooting procedures for the symptom(s) in question are described.
  - 3. Perform each step in the order listed until the malfunction is corrected. DO NOT perform any maintenance task unless the troubleshooting procedure tells you to do so.

---

**3-3. ELECTRICAL TROUBLESHOOTING.**

---

- a. Paragraph 4-31 provides a wiring diagram for troubleshooting the chassis wiring harness.
- b. When troubleshooting any electrical system or component, exercise care in order to prevent electrical shock.



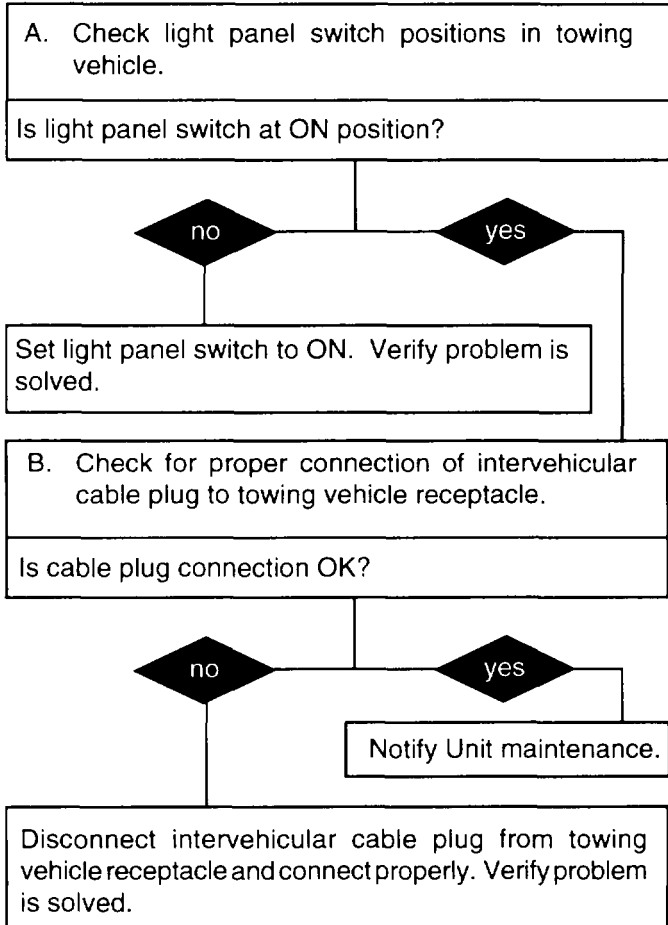
**3-4. QUICK GUIDE TO TROUBLESHOOTING.**

---

<b><u>ITEM</u></b>	<b><u>SYMPTOM</u></b>	<b><u>PARAGRAPH</u></b>	
<b>ELECTRICAL SYSTEM</b>		ONE OR BOTH TAILLIGHTS DO NOT WORK.	para 3-5a(1)
<b>BRAKES</b>		BRAKES WILL NOT RELEASE.	para 3-5b(1)
<b>WHEELS AND TIRES</b>		TIRE WEAR IS ABNORMAL OR UNEVEN.	para 3-5c(1)
<b>SUSPENSION</b>		FRAME HITS SPRING ASSEMBLY OR RESTS	para 3-5d(1)
	ON SPRING BUMPER.		
	TRAILER RIDES HARD OR SWAYS.		para 3-5d(2)

**3-5. TROUBLESHOOTING CHART.**

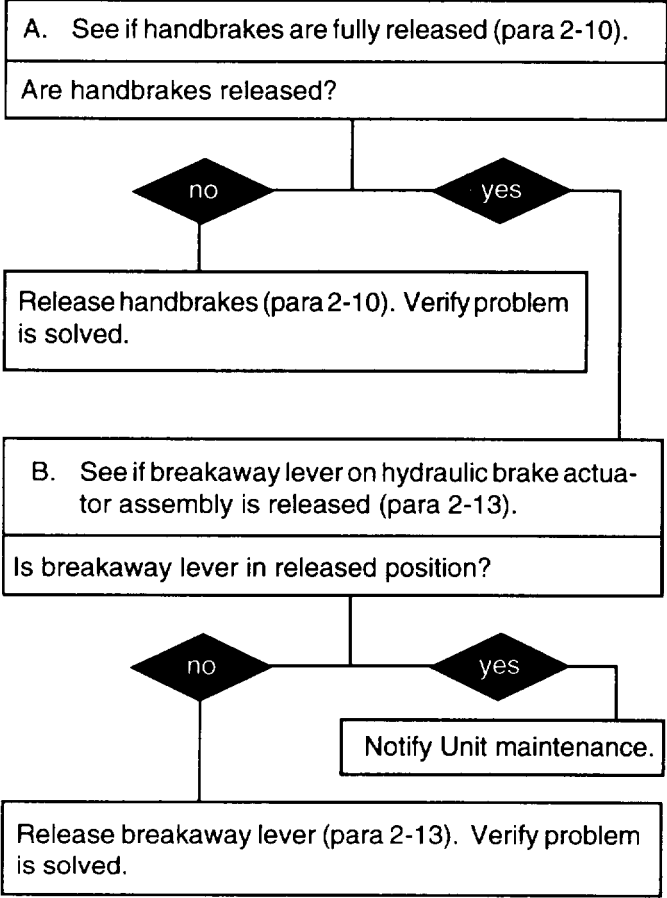
a. ELECTRICAL SYSTEM (1) ONE OR BOTH TAILLIGHTS DO NOT WORK.



**END OF TASK**

3-5. TROUBLESHOOTING CHART (continued).

b. BRAKES (1) BRAKES WILL NOT RELEASE.

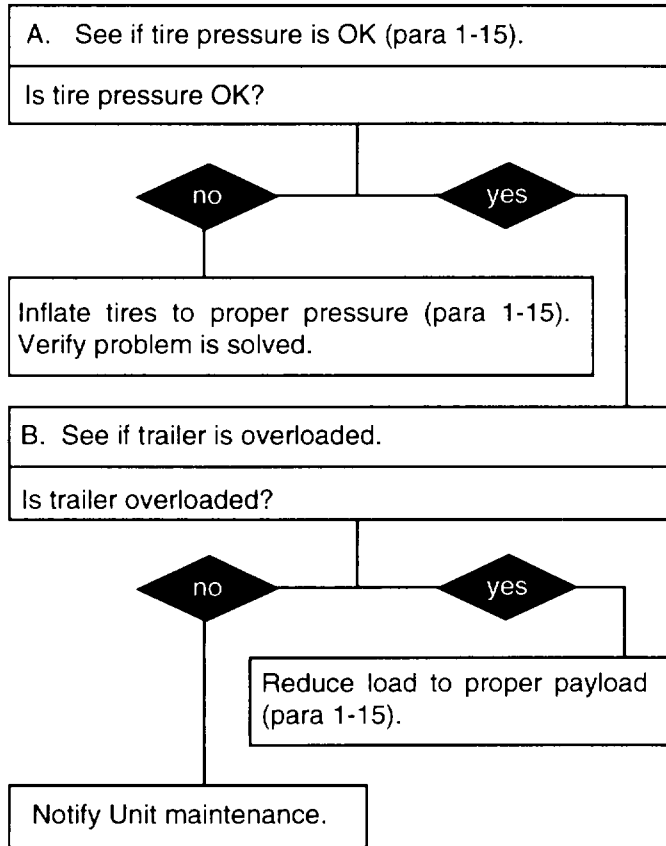


END OF TASK

3-5. TROUBLESHOOTING CHART (continued).

c. WHEELS AND TIRES

(1) TIRE WEAR IS ABNORMAL OR UNEVEN.

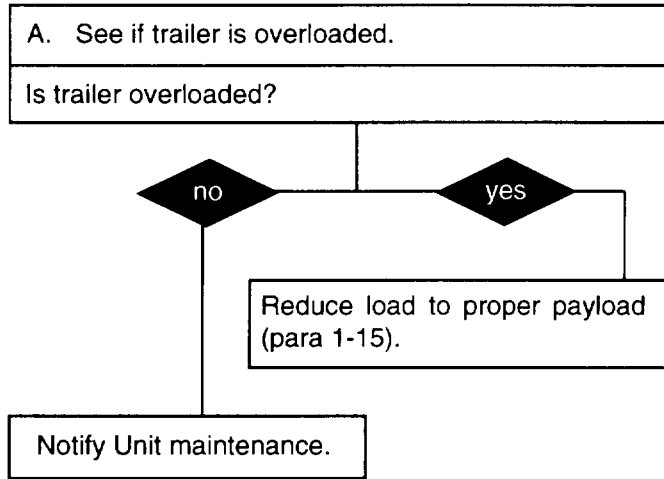


END OF TASK

3-5. TROUBLESHOOTING CHART (continued).

d. SUSPENSION

(1) FRAME HITS SPRING ASSEMBLY OR RESTS ON SPRING BUMPER.

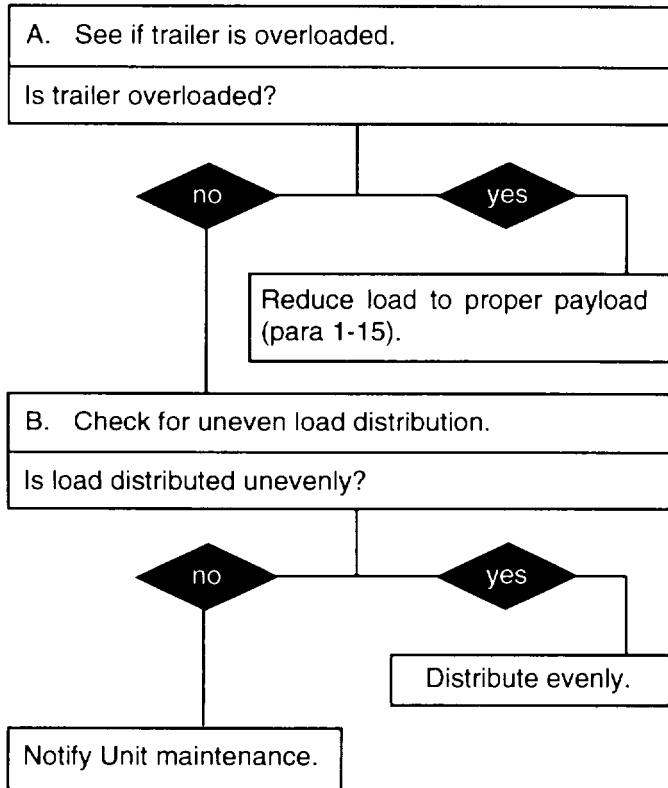


END OF TASK

3-5. TROUBLESHOOTING CHART (continued).

d. SUSPENSION

(2) TRAILER RIDES HARD OR SWAYS.



END OF TASK

**CHAPTER 4  
UNIT MAINTENANCE**

**Section I. REPAIR PARTS; TOOLS; SPECIAL TOOLS; TEST, MEASUREMENT,  
AND DIAGNOSTIC EQUIPMENT (TMDE);  
AND SUPPORT EQUIPMENT**

Paragraph Number	Paragraph Title	Page Number
4-1	General.....	4-1
4-2	Common Tools and Equipment.....	4-1
4-3	Special Tools, TMDE, and Support Equipment.....	4-1
4-4	Repair Parts .....	4-1

**4-1. GENERAL.**

This chapter describes the Unit maintenance tasks to be performed on the M101 Series and M116 Series trailers.

**4-2. COMMON TOOLS AND EQUIPMENT.**

Common tools and equipment are issued to Unit maintenance personnel for maintaining the M101 Series and M116 Series trailers. Common tools and equipment should not be used for purposes other than those prescribed and should be properly stored when not in use. For authorized common tools and equipment applicable to your unit, refer to the Modified Table of Organization and Equipment (MTOE).

**4-3. SPECIAL TOOLS, TMDE, AND SUPPORT EQUIPMENT.**

No special tools, TMDE, or support equipment is required to maintain the trailers.

**4-4. REPAIR PARTS.**

Repair parts are listed and illustrated in Appendix E of this manual.

**Section II. SERVICE UPON RECEIPT**

<b>Paragraph Number</b>	<b>Paragraph Title</b>	<b>Page Number</b>
4-5	General.....	4-2
4-6	Inspection Instructions.....	4-2
4-7	Servicing Instructions .....	4-2

**4-5. GENERAL.**

When a new, used, or reconditioned trailer is received, determine whether it has been properly prepared for service and is capable of performing its mission by following the inspection instructions in paragraph 4-6 and the servicing instructions in paragraph 4-7.

**4-6. INSPECTION INSTRUCTIONS.**

- a. Refer to DD Form 1397 for procedures on unpacking the trailer.
- b. Remove all straps, plywood, tape, seals, and wrappings.

**WARNING**

**Drycleaning solvent P-D-680 is toxic and flammable. Always wear protective goggles and gloves, and use only in a well-ventilated area. Avoid contact with skin, eyes, and clothes, and DO NOT breathe vapors. DO NOT use near open flame or excessive heat.**

- c. Remove rust preventive compound from coated exterior parts of the trailer using drycleaning solvent (Item 15, Appendix F) and a clean rag (Item 13, Appendix F).
- d. Inspect the trailer for damage incurred during shipment. Check also to see if the equipment has been modified.
- e. Check the equipment against the packing list to see if shipment is complete. Report any discrepancies in accordance with Instructions in DA Pam 738-750.

**4-7. SERVICING INSTRUCTIONS.**

- a. Perform all Operator/Crew and Unit preventive maintenance checks and services (PMCS) listed in Tables 2-1 and 4-1. Schedule the next Unit PMCS on DD Form 314.
- b. Lubricate all lubrication points as described in Appendix I, regardless of interval.
- c. If any system of the trailer does not operate properly, refer to the troubleshooting instructions in Chapter 3, Section I (Operator/Crew), or Chapter 4, Section IV (Unit).
- d. Perform a break-in road test of 25 miles (40 km) at a maximum speed of 50 miles per hour (80 kph).
- e. Report all problems on DA Form 2407.



**Section III. UNIT PREVENTIVE MAINTENANCE  
CHECKS AND SERVICES (PMCS)**

Paragraph Number	Paragraph Title	Page Number
4-8	General.....	4-3
4-9	Service Intervals.....	4-3
4-10	Reporting Repairs .....	4-3
4-11	General PMCS Procedures.....	4-3
4-12	Specific PMCS Procedures .....	4-4
Table 4-1	Unit Preventive Maintenance Checks and Services (PMCS) for the M101 and M116 Series Trailers.....	4-5

**4-8. GENERAL.**

To ensure that the M101 Series and M1 16 Series trailers are ready for operation at all times, they must be inspected on a regular basis so that defects may be detected and corrected before they result in serious damage, equipment failure, or injury to personnel. Table 4-1 (p. 4-5) contains a tabulated listing of preventive maintenance checks and services (PMCS) to be performed by Unit maintenance personnel.

**4-9. SERVICE INTERVALS.**

Perform the PMCS procedures listed in Table 4-1 at the following intervals:

- Perform *Semiannual* PMCS procedures once every six months.
- Perform *Annual* PMCS procedures once each year.

**4-10. REPORTING REPAIRS.**

Report all defects and corrective actions on DA Form 2404. If a serious problem is found, report it to your supervisor immediately.

**4-11. GENERAL PMCS PROCEDURES.**

**WARNING**

**Drycleaning solvent P-D-680 is toxic and flammable. Always wear protective goggles and gloves, and use only in a well-ventilated area. Avoid contact with skin, eyes, and clothes, and DO NOT breathe vapors. DO NOT use near open flame or excessive heat.**

- a. Keep equipment clean. Dirt, oil, and debris may cover up a serious problem. Clean as you work and as needed. Use drycleaning solvent (Item 15, Appendix F) on all metal surfaces. Use detergent (Item 5, Appendix F) and water on rubber, plastic, and painted surfaces.
- b. While performing PMCS, inspect the following components:

---

#### 4-11. GENERAL PMCS PROCEDURES (continued).

---

**Bolts, Nuts, and Screws.** Make sure they are not loose, missing, bent, or broken. Tighten any that are loose.

**Welds.** Inspect for gaps where parts are welded together. Report bad welds to your supervisor.

**Wiring Harnesses, Wires, and Connectors.** Inspect for cracked or broken insulation, bare wires, and loose or broken connectors. Repair or replace as necessary.

**Hydraulic Brake Lines and Fittings.** Inspect for wear, damage, and leaks. Make sure fittings are tight. If a leak originates from a loose fitting, tighten it. If a component is broken or worn, correct the problem if authorized by the Maintenance Allocation Chart (MAC) (Appendix B). If not authorized, report it to your supervisor.

---

#### 4-12. SPECIFIC PMCS PROCEDURES.

---

- a. Unit PMCS procedures are provided in Table 4-1. Always perform PMCS in the order listed. Once PMCS becomes a routine, problems can be spotted quickly. If anything wrong is discovered through PMCS, perform the appropriate troubleshooting task listed in Section IV of this chapter. If any component or system is not serviceable or if the service given does not correct the problem, notify your supervisor.
- b. The PMCS procedures listed in Table 4-1 are to be performed at two intervals: semiannual and annual. Before performing PMCS, read all the checks required for the applicable interval and prepare the tools needed to make all checks. Have several clean rags (Item 13, Appendix F) handy. Perform ALL inspections at the applicable interval.
- c. Explanations of the column headings in Table 4-1 are as follows:

**Item No.** The Item number column of the PMCS table is used for reference. When completing DA Form 2404, include the item number for the check/service indicating a fault. Item numbers also appear in the order that you must do checks and services for the intervals listed.

**Interval** This column tells you when to do a specific check or service.

**Item To Check/Service** This column names the item to be checked or serviced.

**Procedure** This column tells you how to do the required checks and services. Carefully follow these instructions. If you do not have the tools, or if the procedure tells you to, have Unit maintenance do the work.

**Not Fully Mission Capable If:** Information in this column tells you what faults will keep the equipment from being capable of performing its mission. If PMCS reveals faults listed in this column, do not operate the equipment. Follow standard operating procedures for maintaining the equipment or reporting equipment failures.

Table 4-1. UNIT PREVENTIVE MAINTENANCE CHECKS AND SERVICES (PMCS) FOR THE M101 AND M116 SERIES TRAILERS

Item No.	Interval	Item to Check/ Service	Procedure	Not Fully Mission Capable If:
1	Semiannual	Composite Stoplight-Taillights	<p style="text-align: center;"><b>NOTE</b></p> <p>Perform Operator/Crew PMCS prior to or along with Unit PMCS.</p> <p>Check for broken or cracked lenses or damaged composite stoplight-taillights and replace as required (para 4-28).</p>	
2	Semiannual	Intervehicular Cable	Check for cuts, breaks, frayed wires, or damaged plug. Replace defective components as required.	
3	Semiannual	Drawbar Coupler	Check for security of mounting. Make sure drawbar coupler is not excessively worn at the end.	
4	Semiannual	Safety Chains	Check to make sure safety chains are there and have no broken links.	
5	Semiannual	Reflectors (M101A2 and M101A3)	Check for cracked or broken reflectors and replace as required (para 4-62).	
6	Semiannual	Front Support Leg	Inspect brackets and front support leg for bent or broken parts.	
7	Semiannual	Hydraulic Brake System	Service master cylinder (Appendix I).	
8	Annual	Data Plates	Make sure data plates can be read and are firmly attached. Replace if damaged or disfigured (para 4-63).	
9	Annual	Suspension Assemblies	<p>a. Inspect shackles, bushings, shackle pins, and spring eyes for damage or broken parts.</p> <p>b. Inspect spring assemblies for cracked or shifted leaves.</p> <p>c. Inspect spring hangers for obvious damage.</p> <p>d. Inspect shock absorbers for damage and security of mounting.</p>	



**Section IV. UNIT TROUBLESHOOTING PROCEDURES**

<b>Paragraph Number</b>	<b>Paragraph Title</b>	<b>Page Number</b>
4-13	General.....	4-7
4-14	Electrical Troubleshooting.....	4-7
4-15	Quick Guide to Troubleshooting.....	4-9
4-16	Troubleshooting Chart.....	4-10

**4-13. GENERAL.**

- a. This section provides information for identifying and correcting malfunctions that may develop while operating or maintaining the trailers.
- b. The Quick Guide to Troubleshooting (para 4-15) lists common malfunctions of the trailer or its components and refers you to the Troubleshooting Chart (para 4-16) for the appropriate troubleshooting procedures. You should perform the tests/inspections and corrective actions in the order listed.
- c. If you are unsure of the location of an item mentioned in troubleshooting, refer to paragraph 1-12 or to the maintenance task where the item is replaced.
- d. Before performing troubleshooting, read and follow all safety instructions listed in the warning summary at the beginning of this manual.
- e. This section cannot list all malfunctions that may occur, nor all tests or inspections and corrective actions. If a malfunction is not listed or is not corrected by the corrective actions listed, notify your supervisor.
- f. When troubleshooting a malfunction:
  - Locate the symptom(s) in the Quick Guide to Troubleshooting (para 4-15) that best describes the malfunction.
  - Turn to the page in the Troubleshooting Chart (para 4-16) where the troubleshooting procedures for the symptom(s) in question are described.
  - Perform each step in the order listed until the malfunction is corrected. DO NOT perform any maintenance task unless the troubleshooting procedure tells you to do so.

**4-14. ELECTRICAL TROUBLESHOOTING.**

- a. Paragraph 4-31 provides a schematic diagram for troubleshooting the chassis wiring harness.
- b. When troubleshooting any electrical system or component, exercise care in order to prevent electrical shock.

**WARNING**

**When troubleshooting electrical system or electrical components, be certain MASTER switch is OFF between every step unless otherwise directed. To prevent injury due to electrical shock, remove all jewelry and metal objects when working on electrical system.**

---

**4-14. ELECTRICAL TROUBLESHOOTING (continued).**

---

- c. The multimeter is used throughout electrical troubleshooting. When using the multimeter, make sure it is used with a probe kit.
- d. When performing a continuity test, make sure all connectors and/or leads are disconnected from their components. Probe the pins (or sockets) with a multimeter.
- e. When probing has been completed, place the red lead on the second pin (or connector) and probe with the black lead in the same order. Do this until every pin has been probed with the red lead of the multimeter. Then place the black lead of the multimeter on the connector and place the red lead on each pin (or socket) on the connector.
- f. If continuity is present between any two points, a short exists. Shorts must be repaired in order to continue any operation.
- g. If instructed in a procedure to skip a pin (or socket) during a continuity test, it is because the pin (or socket) is not used or is shielded.
- h. When a repair or replacement of a lead or wiring harness has been done, do the continuity test again to make sure the problem has been corrected.
- i. When performing a continuity check, connect the meter probes to both terminals of the circuit you are testing. Read the meter. Interpret the results. If the needle swings over to near 0 on the top scale, the circuit has continuity. If the needle does not move, the circuit is open. If the needle jumps or flickers, there is a loose connection.
- j. Check light bulbs for cracks or discoloration. Check the continuity of a light bulb by placing one probe of the meter to the metal button base connection of the bulb and one probe to the metal side of the base. If the meter needle swings over to 0 on the top scale, the circuit has continuity. If the meter needle does not move, the circuit is open, indicating a defect.

---

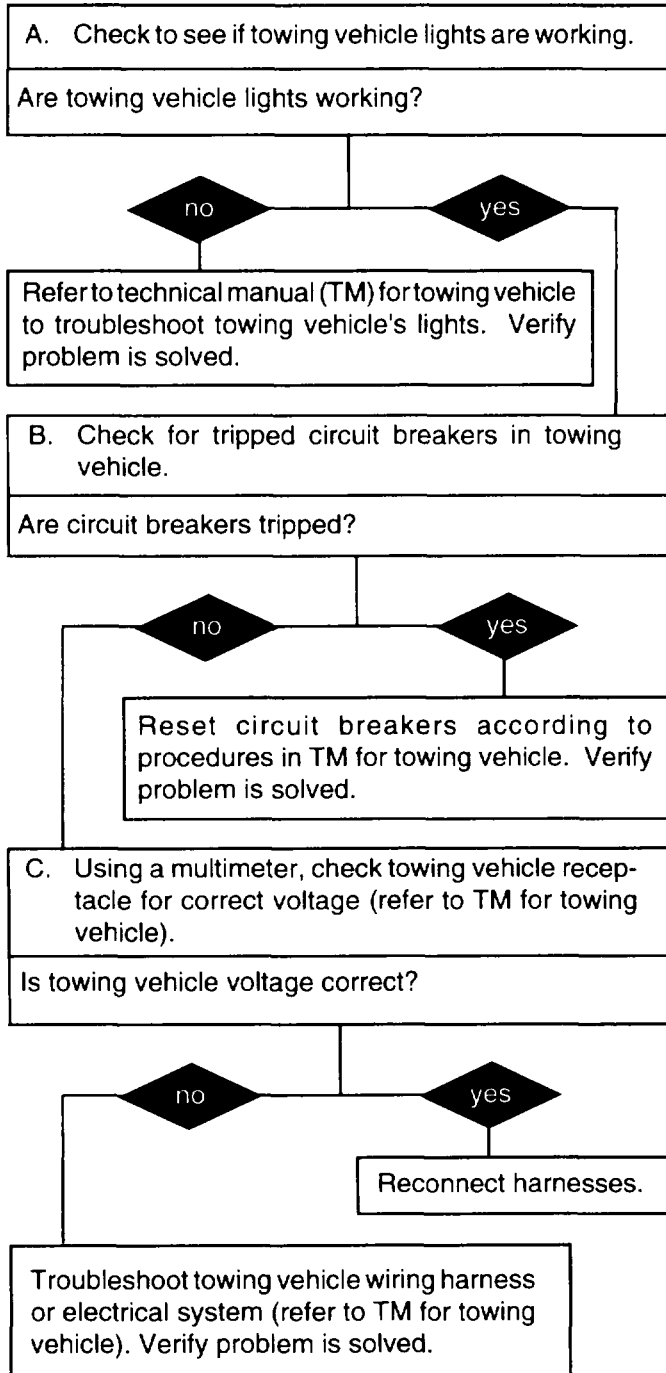
**4-15. QUICK GUIDE TO TROUBLESHOOTING.**


---

<b><u>ITEM</u></b>	<b><u>SYMPTOM</u></b>	<b><u>PARAGRAPH</u></b>
ELECTRICAL SYSTEM	NEITHER TAILLIGHT WORKS.	para 4-16a(1)
	ONE TAILLIGHT DOES NOT WORK.	para 4-16a(2)
	LAMPS/LED'S ARE DIM OR FLICKERING.	para 4-16a(3)
AXLE	AXLE IS LOOSE OR OUT OF ALIGNMENT.	para 4-16b(1)
BRAKES	HANDBRAKES WILL NOT OPERATE.	para 4-16c(1)
	BRAKES WILL NOT RELEASE.	para 4-16c(2)
	BRAKES DO NOT HOLD TRAILER AT HALT.	para 4-16c(3)
	HYDRAULIC BRAKE SYSTEM WILL NOT OPERATE.	para 4-16c(4)
WHEELS AND TIRES	TIRE WEAR IS ABNORMAL OR UNEVEN.	para 4-16d(1)
	WHEEL IS WOBBLY.	para 4-16d(2)
FRONT SUPPORT LEG	FRONT SUPPORT LEG WILL NOT SWING UP OR DOWN.	para 4-16e(1)
REAR STABILIZER	REAR STABILIZER WILL NOT OPERATE.	para 4-16f(1)
SUSPENSION	FRAME HITS SPRING ASSEMBLY OR RESTS ON SPRING BUMPER.	para 4-16g(1)
	TRAILER RIDES HARD OR SWAYS.	para 4-16g(2)
	SPRING ASSEMBLY IS NOISY.	para 4-16g(3)

**4-16. TROUBLESHOOTING CHART.**

a. ELECTRICAL SYSTEM (1) NEITHER TAILLIGHT WORKS.

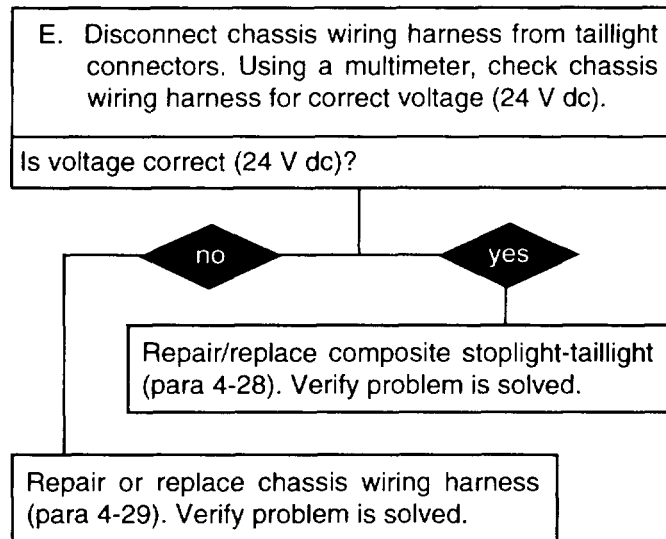
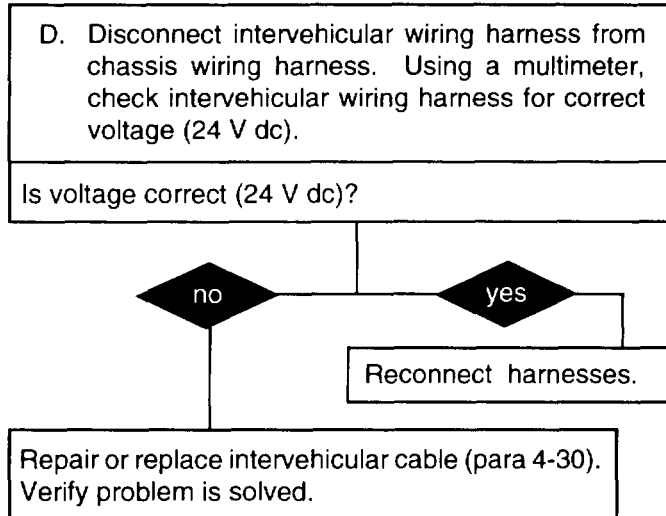




4-16. TROUBLESHOOTING CHART (continued).

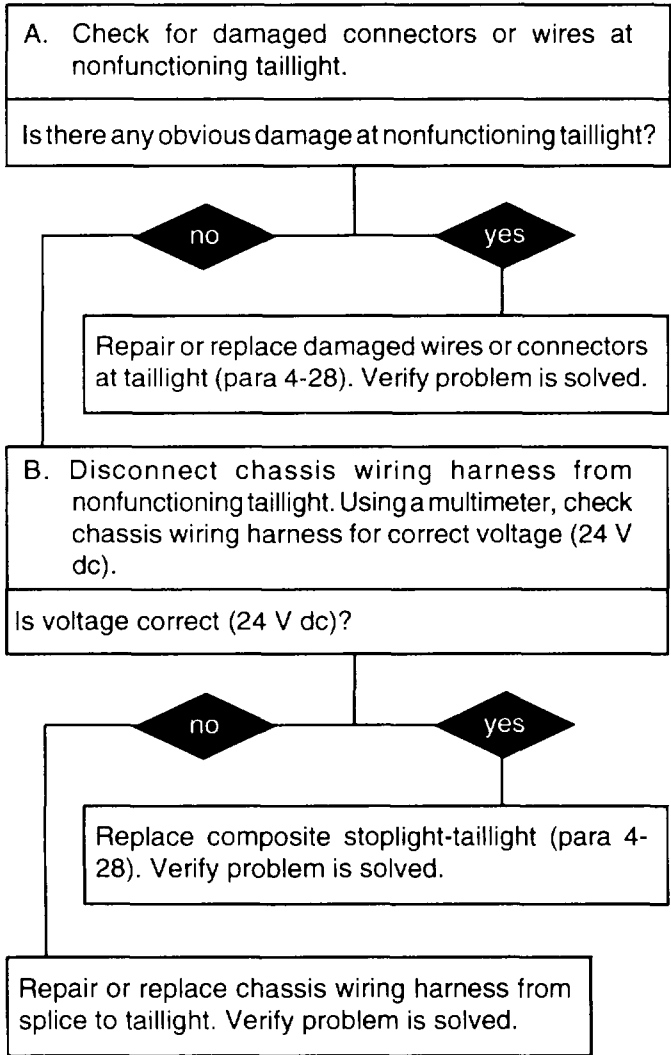
a. ELECTRICAL SYSTEM (continued) (1) NEITHER TAILLIGHT WORKS (continued).

CONTINUED FROM C



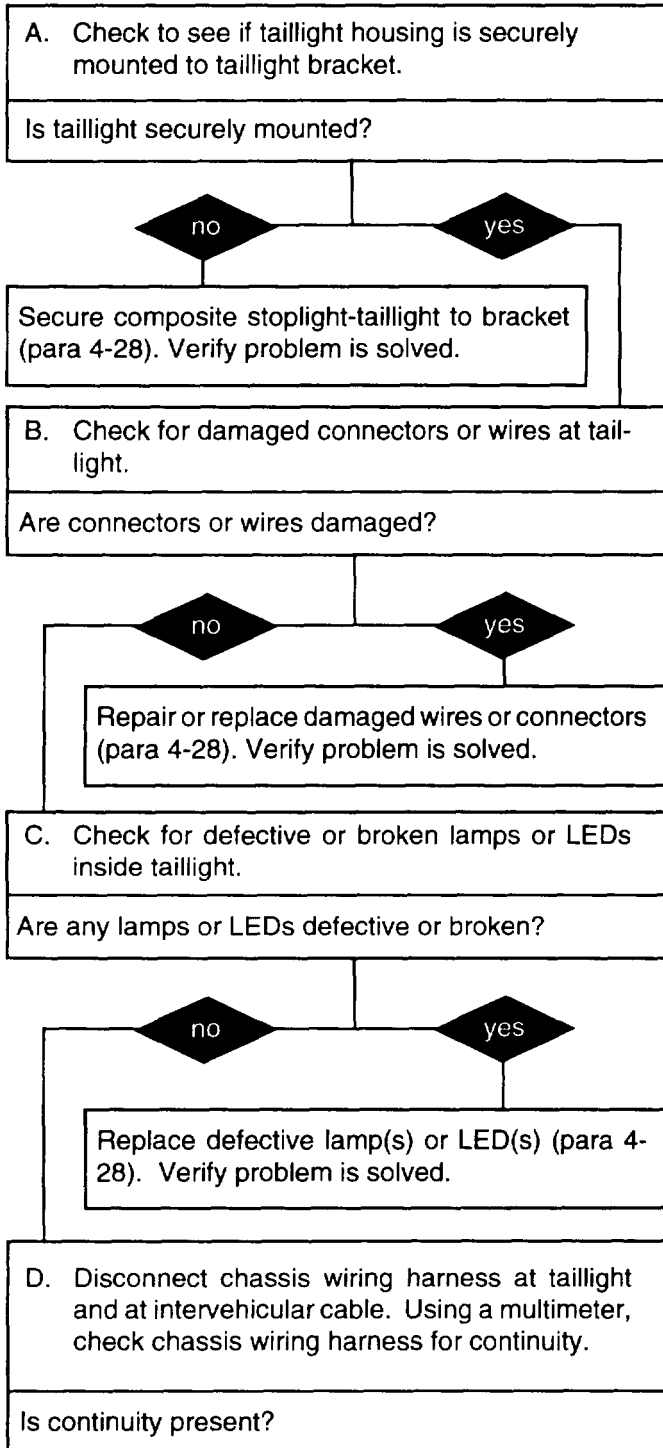
**4-16. TROUBLESHOOTING CHART (continued).**

a. ELECTRICAL SYSTEM (continued) (2) ONE TAILLIGHT DOES NOT WORK.



**4-16. TROUBLESHOOTING CHART (continued).**

a. ELECTRICAL SYSTEM (continued) (3) LAMPS/LED'S ARE DIM OR FLICKERING.

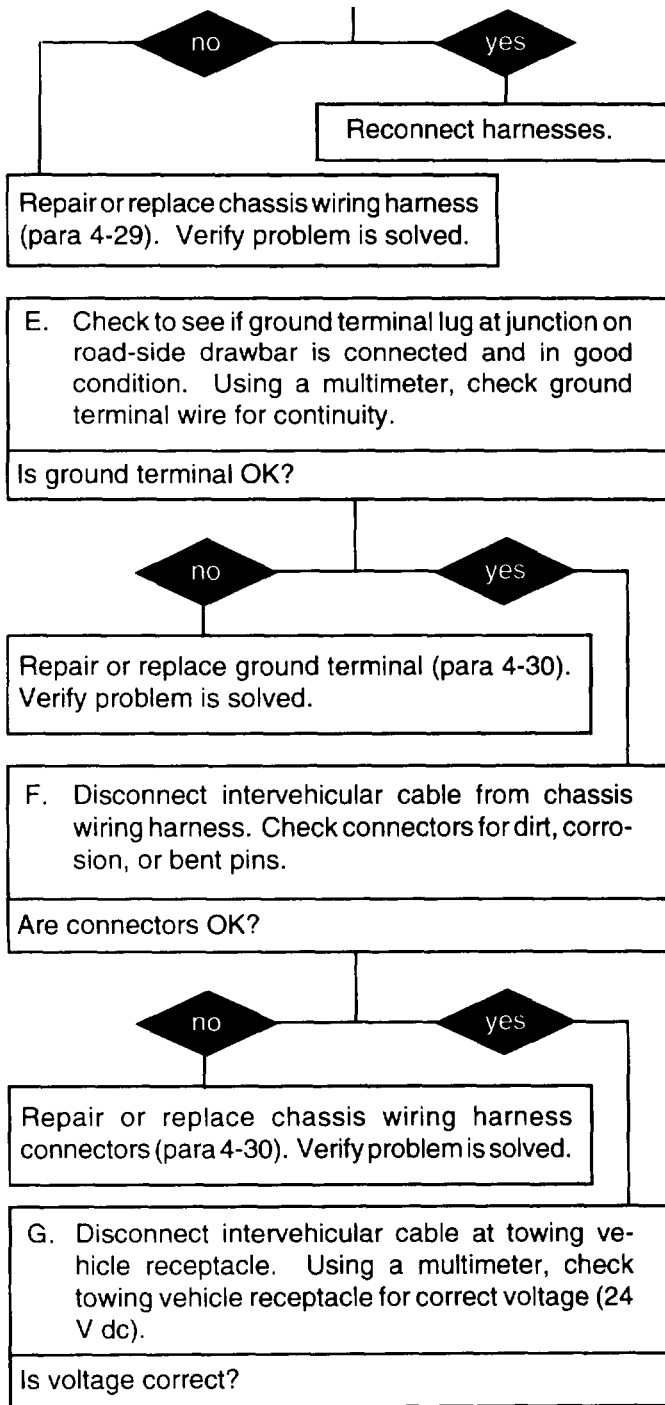


continued on next page

4-16. TROUBLESHOOTING CHART (continued).

a. ELECTRICAL SYSTEM (continued) (3) LAMPS/LED'S ARE DIM OR FLICKERING (continued).

CONTINUED FROM D

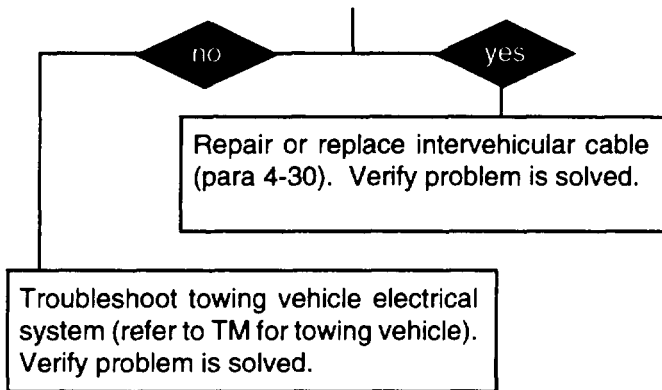


4-16. TROUBLESHOOTING CHART (continued).

a. ELECTRICAL SYSTEM (continued)

(3) LAMPS/LED'S ARE DIM OR FLICKERING (continued).

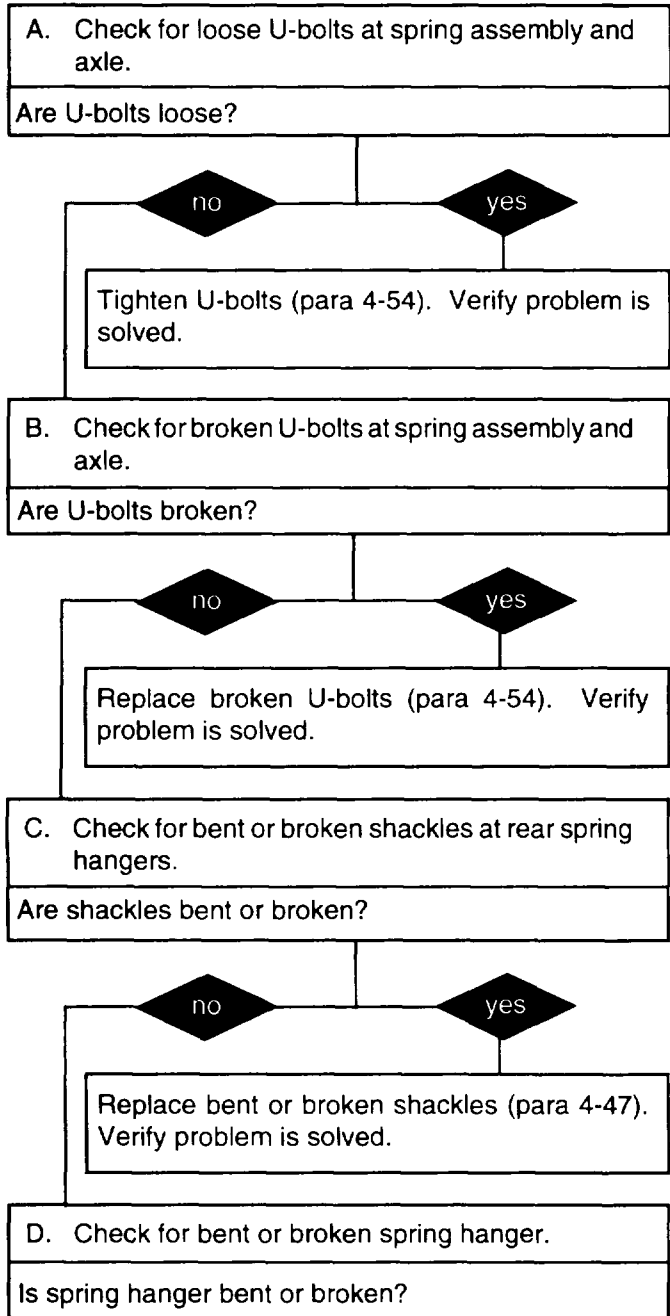
CONTINUED FROM G



END OF TASK

4-16. TROUBLESHOOTING CHART (continued).

b. AXLE (1) AXLE IS LOOSE OR OUT OF ALIGNMENT.



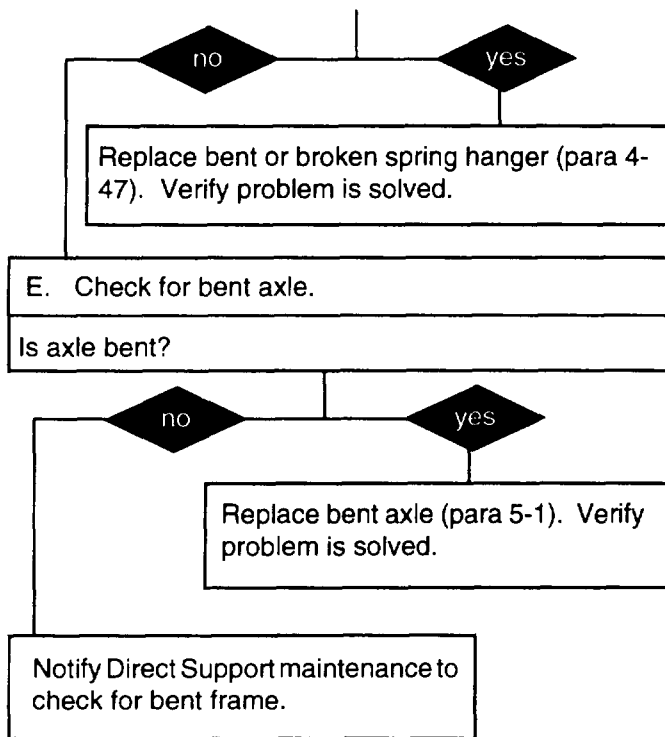
continued on next page

4-16. TROUBLESHOOTING CHART (continued).

b. AXLE (continued)

(1) AXLE IS LOOSE OR OUT OF ALIGNMENT (continued).

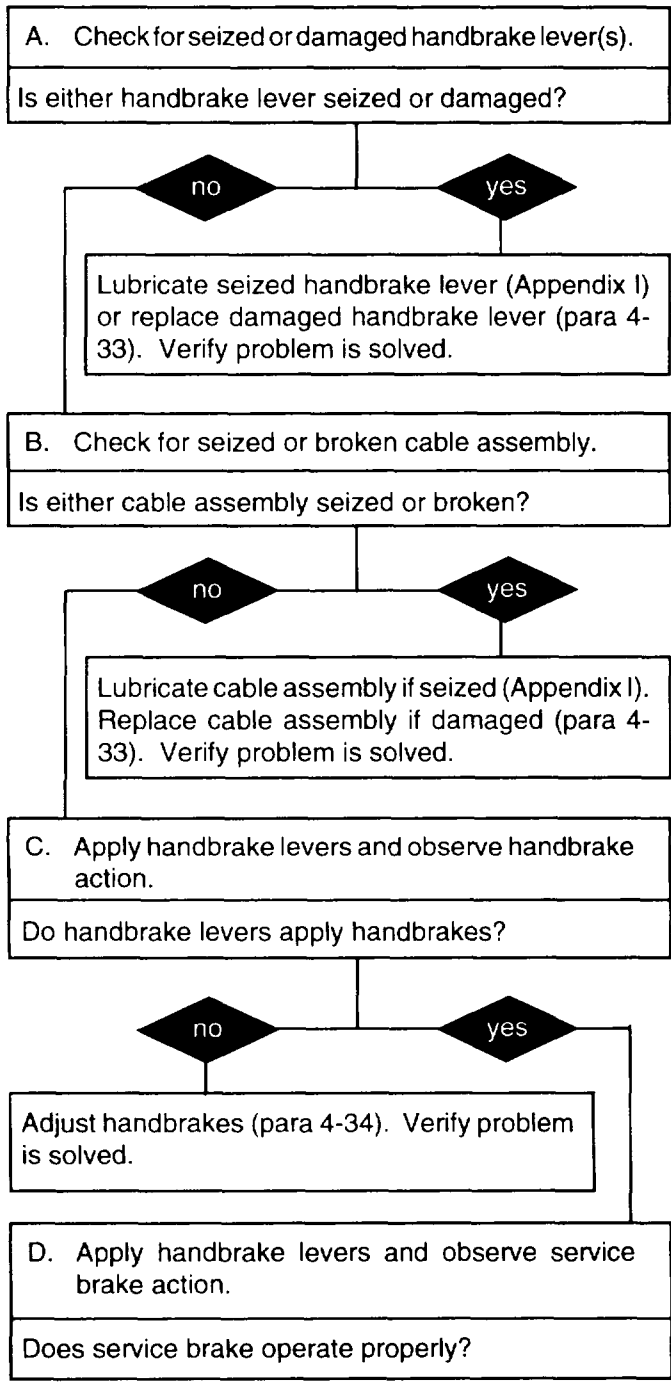
CONTINUED FROM D



END OF TASK

4-16. TROUBLESHOOTING CHART (continued).

c. BRAKES (1) HANDBRAKES WILL NOT OPERATE.



continued on next page

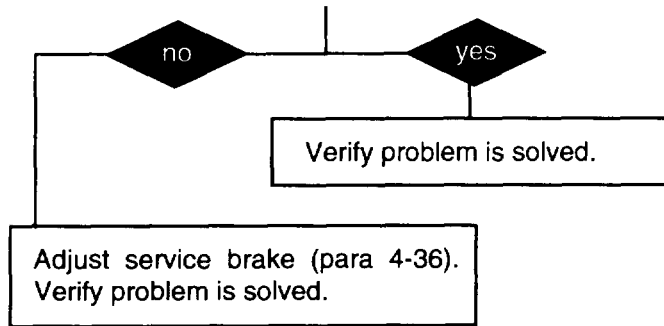


4-16. TROUBLESHOOTING CHART (continued).

c. BRAKES (continued)

(1) HANDBRAKES WILL NOT OPERATE (continued).

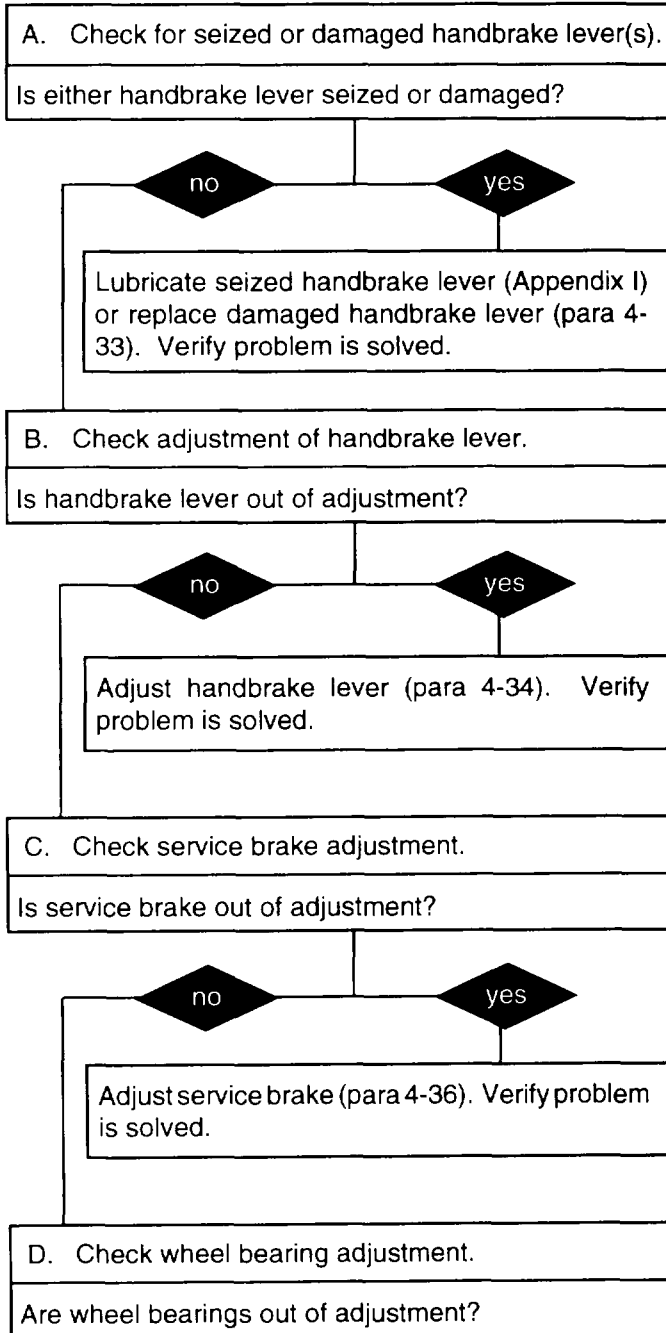
CONTINUED FROM D



END OF TASK

**4-16. TROUBLESHOOTING CHART (continued).**

c. BRAKES (continued) (2) BRAKES WILL NOT RELEASE.



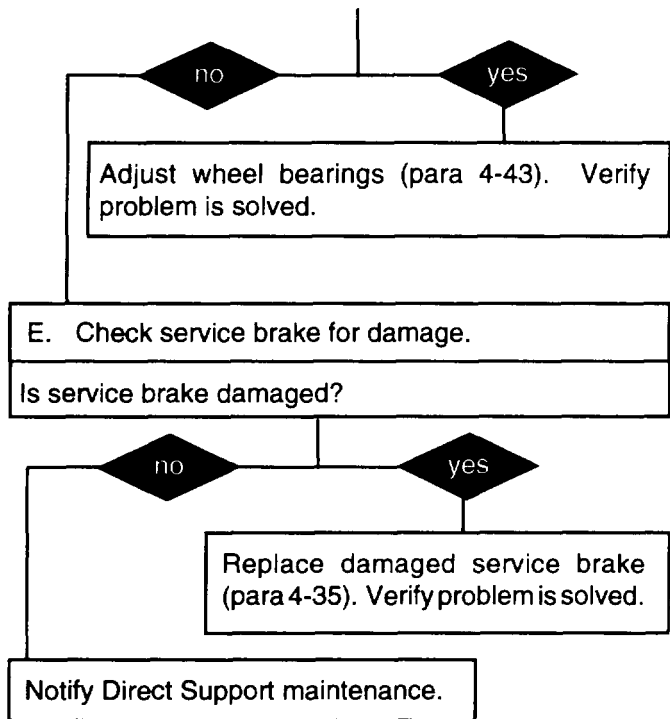
continued on next page

4-16. TROUBLESHOOTING CHART (continued).

c. BRAKES (continued)

(2) BRAKES WILL NOT RELEASE.

CONTINUED FROM D

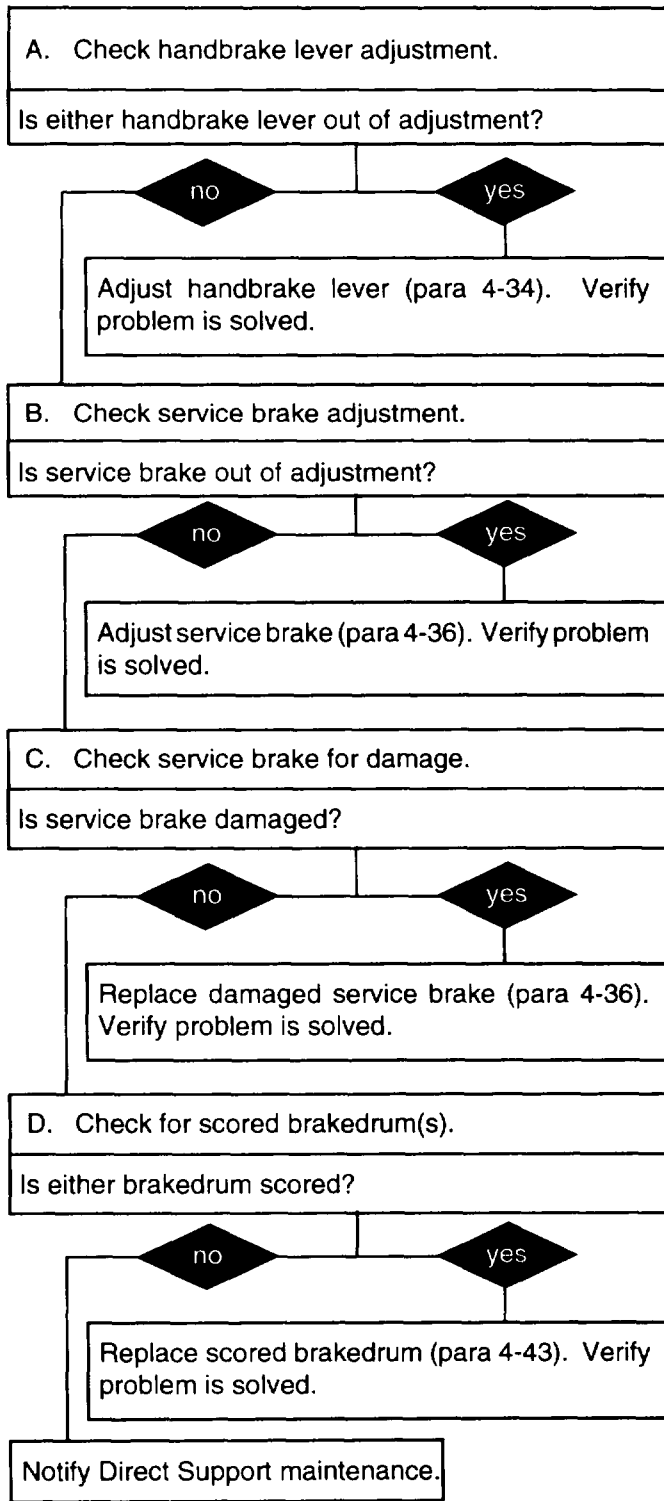


END OF TASK

4-16. TROUBLESHOOTING CHART (continued).

c. BRAKES (continued)

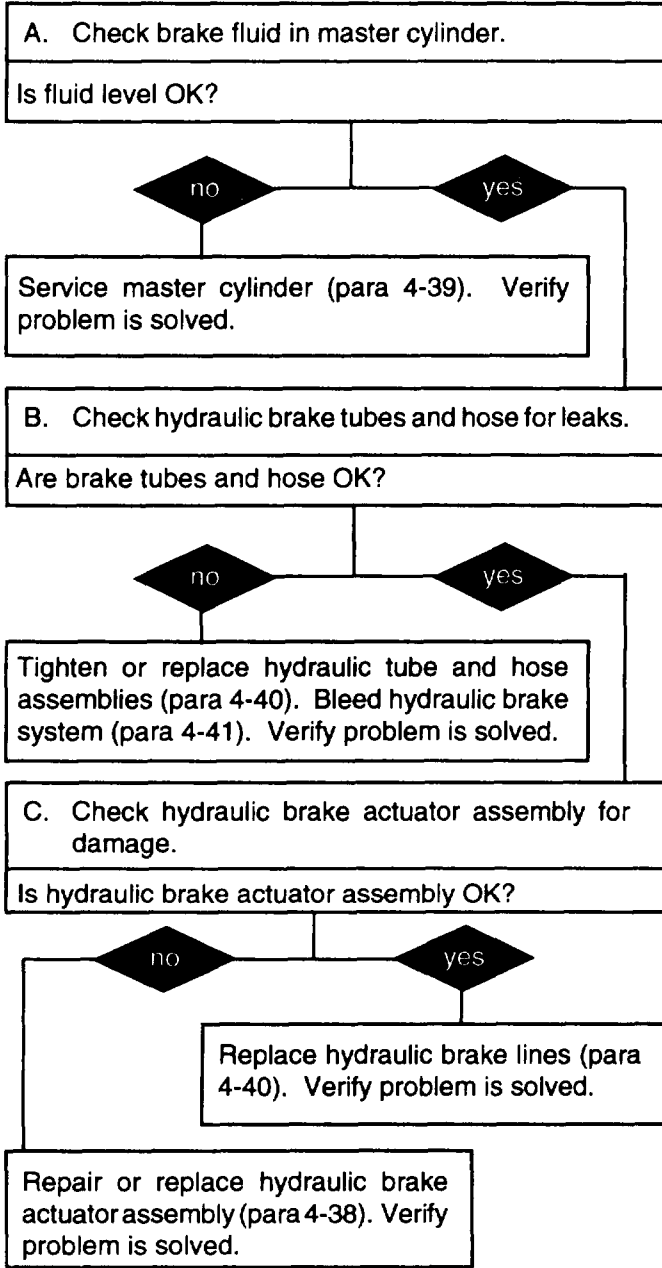
(3) BRAKES DO NOT HOLD TRAILER AT HALT.



END OF TASK

4-16. TROUBLESHOOTING CHART (continued).

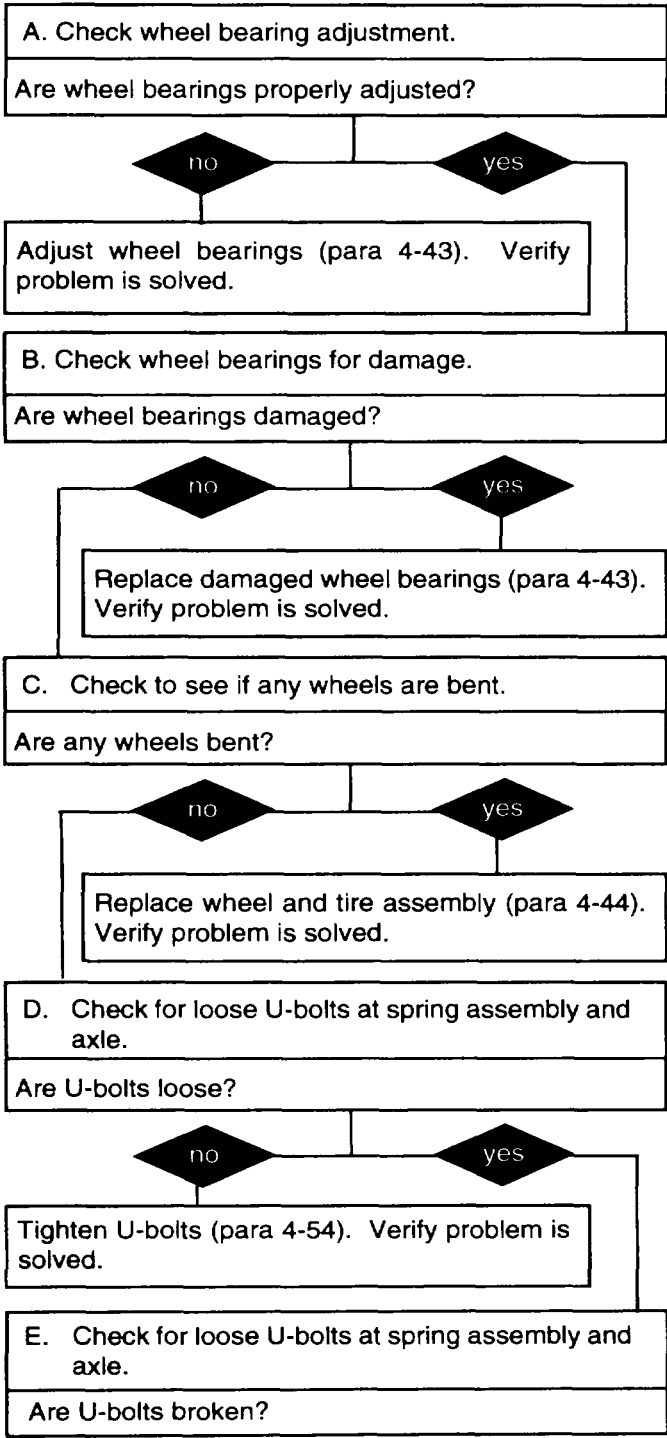
c. BRAKES (continued) (4) HYDRAULIC BRAKE SYSTEM WILL NOT OPERATE.



END OF TASK

4-16. TROUBLESHOOTING CHART (continued).

d. WHEELS AND TIRES (1) TIRE WEAR IS ABNORMAL OR UNEVEN.

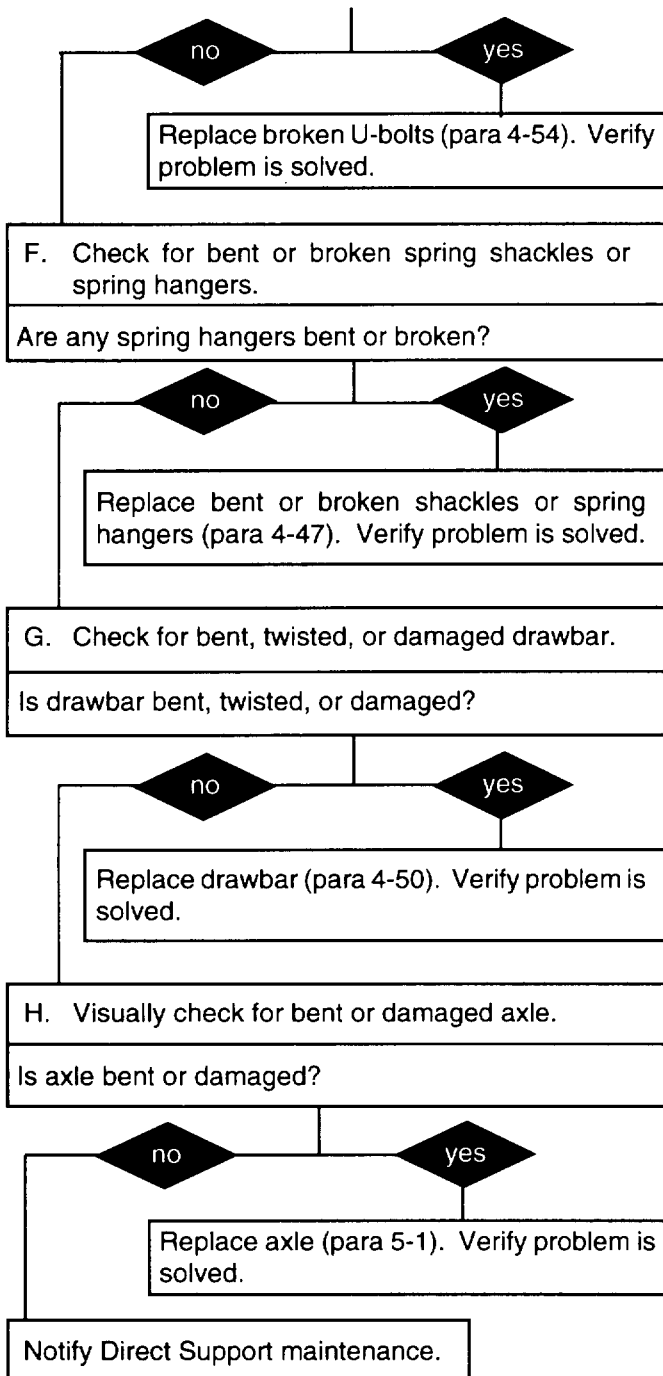


continued on next page

**4-16. TROUBLESHOOTING CHART (continued).**

d. WHEELS AND TIRES (continued) (1) TIRE WEAR IS ABNORMAL OR UNEVEN (continued).

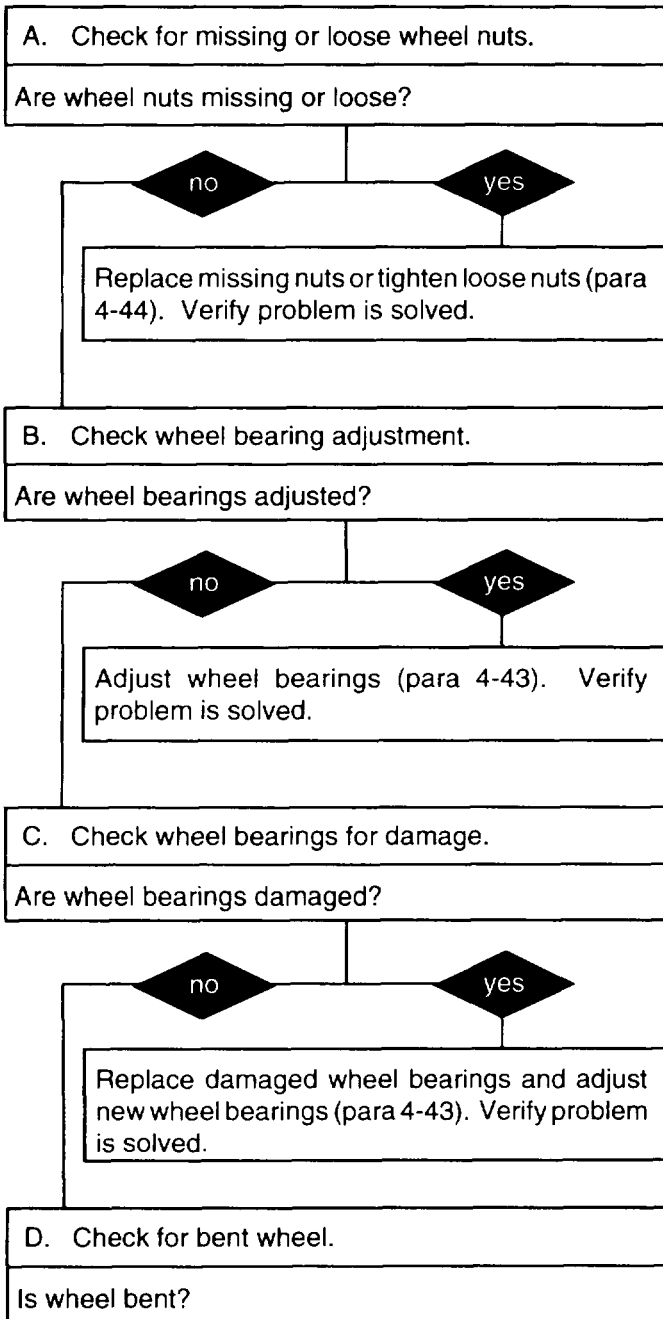
**CONTINUED FROM D**



**END OF TASK**

**4-16. TROUBLESHOOTING CHART (continued).**

d. WHEELS AND TIRES (continued) (1) WHEEL IS WOBBLY.

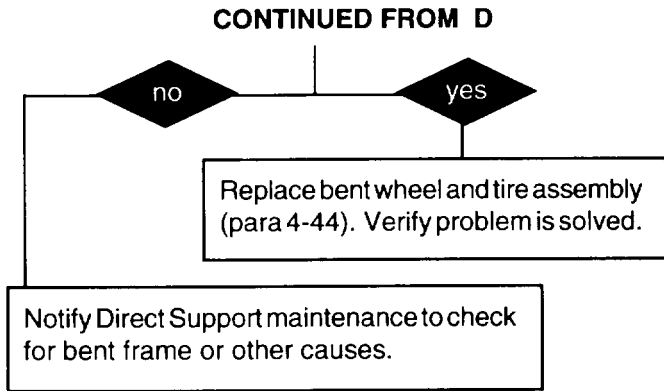


continued on next page



4-16. TROUBLESHOOTING CHART (continued).

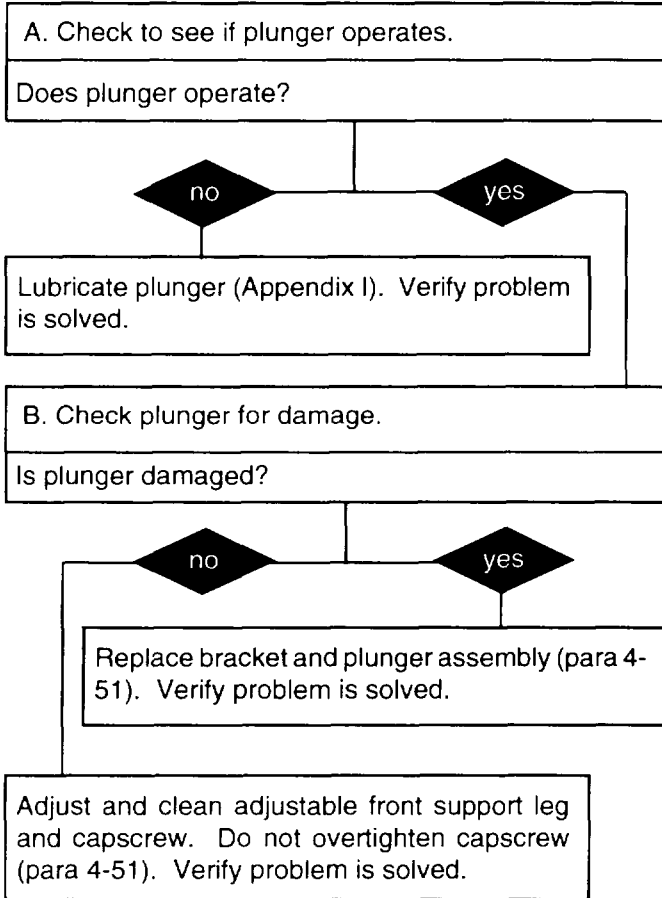
d. WHEELS AND TIRES (continued) (2) WHEEL IS WOBBLY (continued).



**END OF TASK**

**4-16. TROUBLESHOOTING CHART (continued).**

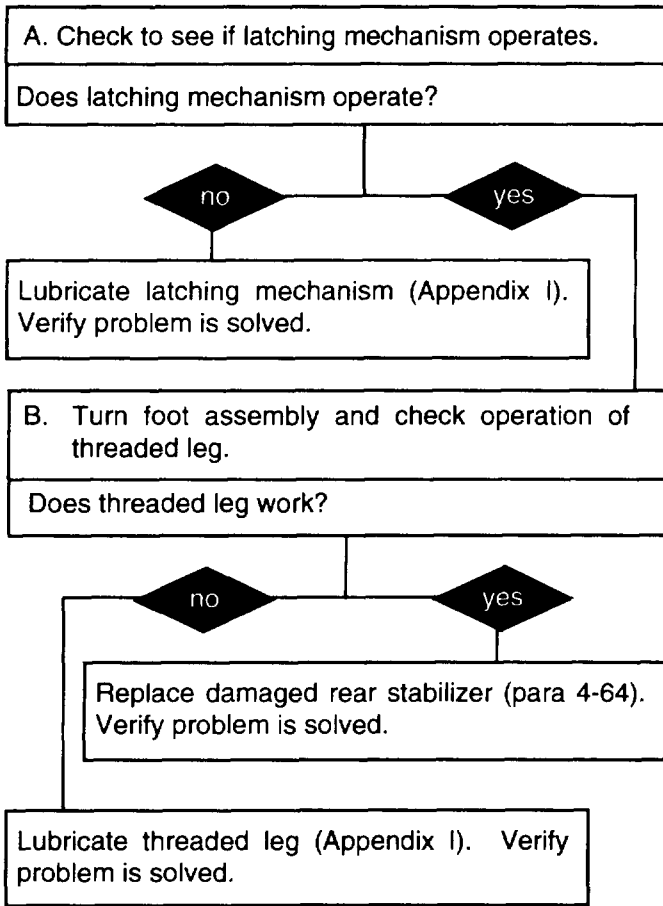
e. FRONT SUPPORT LEG (1) FRONT SUPPORT LEG WILL NOT SWING UP OR DOWN.



**END OF TASK**

4-16. TROUBLESHOOTING CHART (continued).

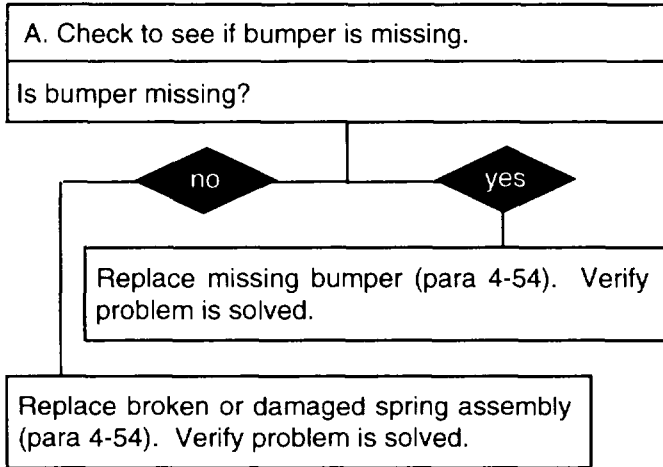
f. REAR STABILIZER (1) REAR STABILIZER WILL NOT OPERATE.



END OF TASK

**4-16. TROUBLESHOOTING CHART (continued).**

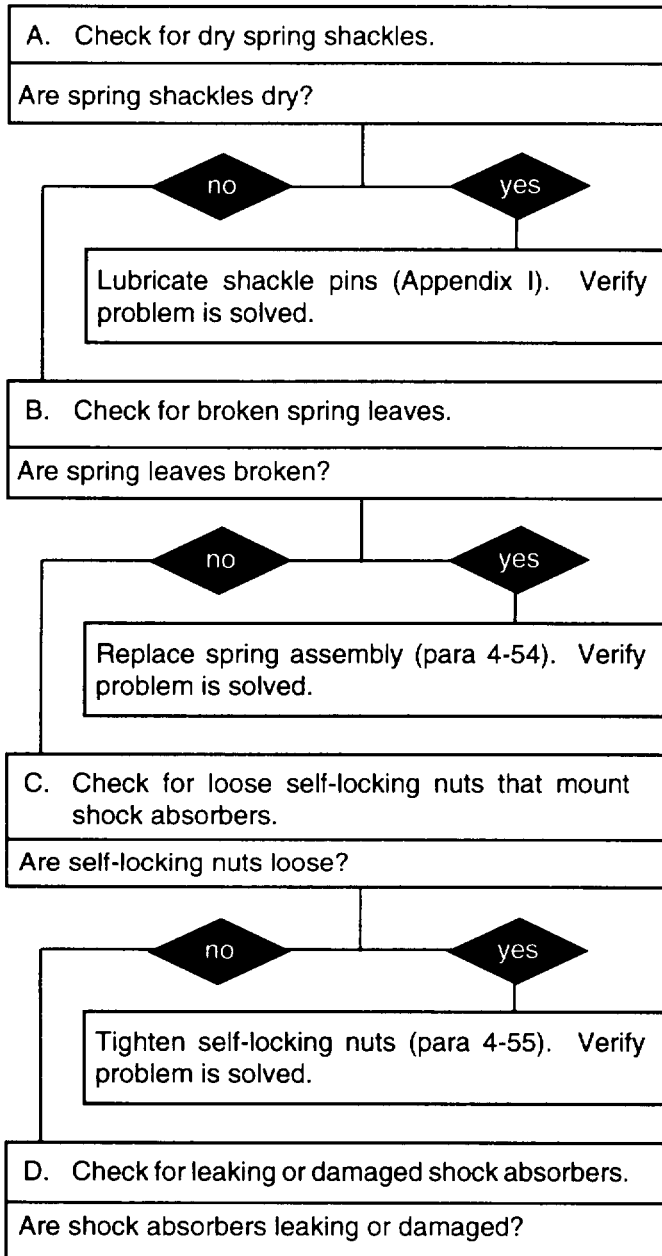
g.	SUSPENSION	(1)	FRAME HITS SPRING ASSEMBLY OR RESTS ON SPRING BUMPER
----	------------	-----	--



**END OF TASK**

**4-16. TROUBLESHOOTING CHART (continued).**

**g. SUSPENSION (continued) (2) TRAILER RIDES HARD OR SWAYS.**

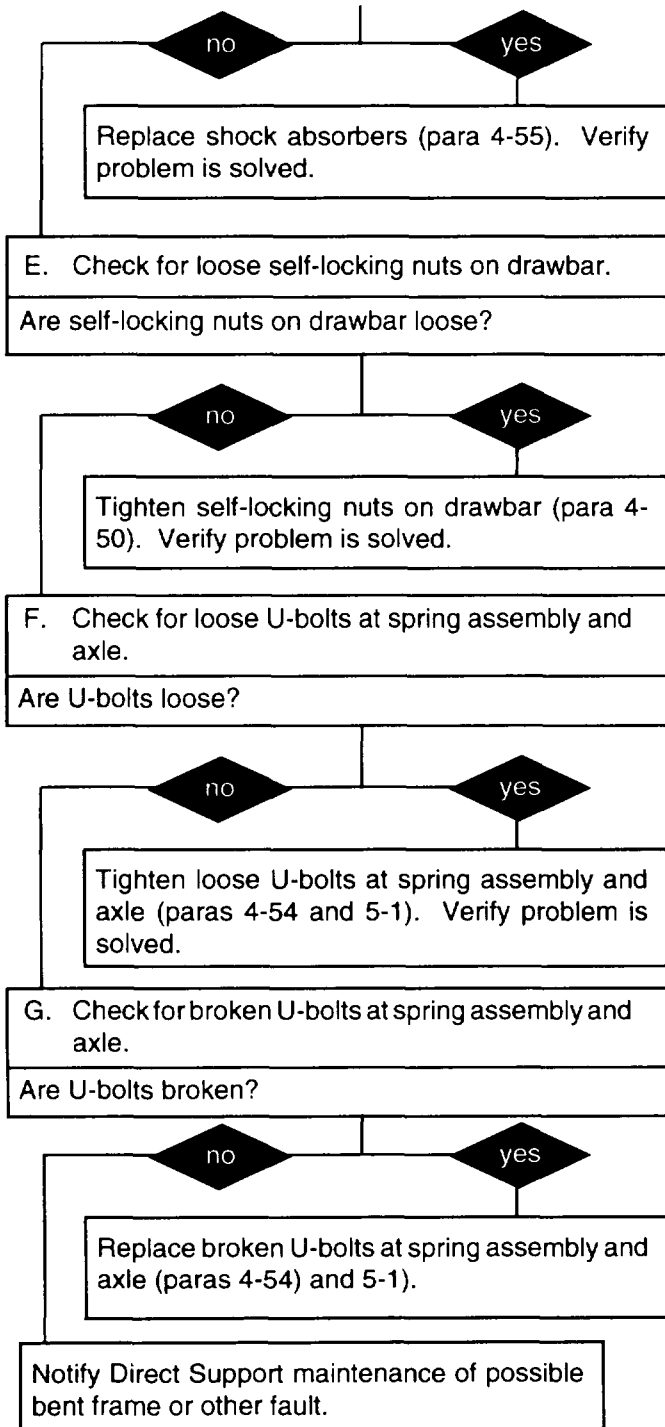


continued on next page

4-16. TROUBLESHOOTING CHART (continued).

g. SUSPENSION (continued) (2) TRAILER RIDES HARD OR SWAYS (continued).

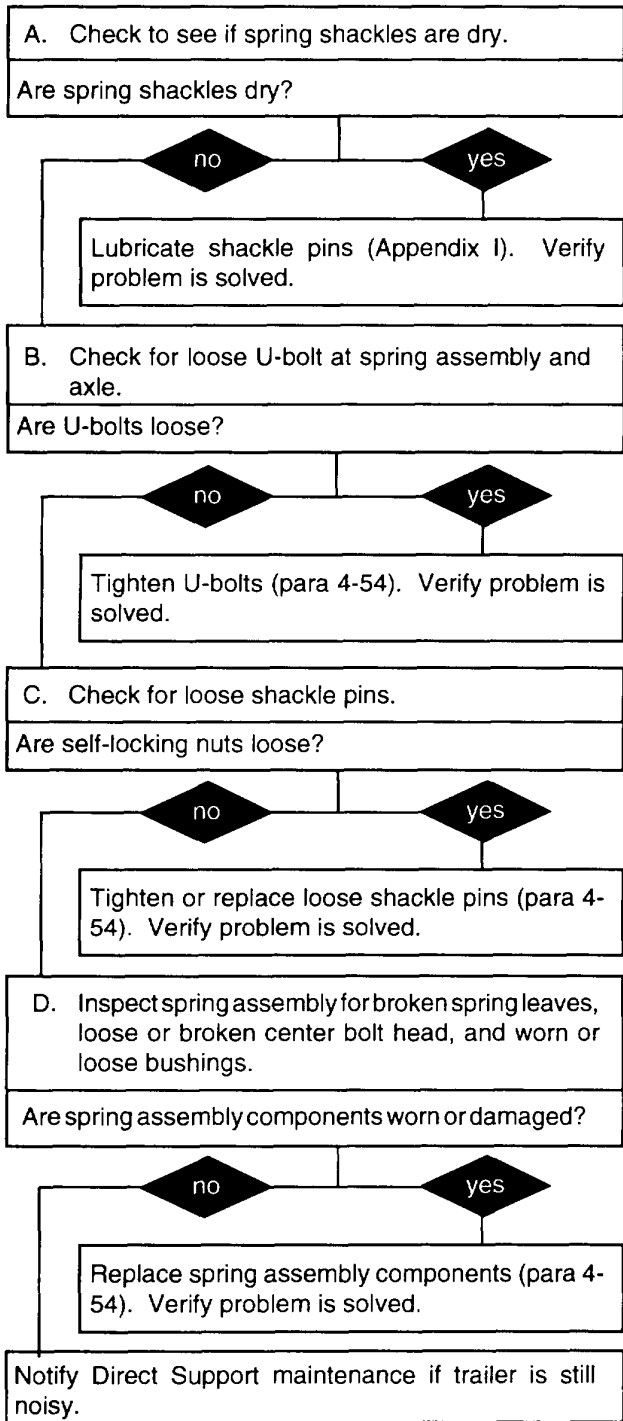
CONTINUED FROM D



END OF TASK

**4-16. TROUBLESHOOTING CHART (continued).**

g. SUSPENSION (continued) (3) SPRING ASSEMBLY IS NOISY.



**END OF TASK**

**Section V. GENERAL MAINTENANCE INSTRUCTIONS**

<b>Paragraph Number</b>	<b>Paragraph Title</b>	<b>Page Number</b>
4-17	General.....	4-34
4-18	Work Safety.....	4-34
4-19	Cleaning Instructions.....	4-35
4-20	Inspection Instructions.....	4-36
4-21	Tagging Parts.....	4-37
4-22	Preservation of Parts.....	4-37
4-23	Painting.....	4-37
4-24	Electrical Ground Points.....	4-38
4-25	Hydraulic Brake Lines and Ports.....	4-38
4-26	Fluid Disposal.....	4-38

**4-17. GENERAL.**

- a. These general maintenance instructions contain general shop practices and specific procedures you must be familiar with to properly maintain your M101 and M116 Series trailers. You should read and understand these practices and procedures before performing any maintenance task.
- b. Before beginning a task find out how much repair, modification, or replacement is needed to fix the equipment. Sometimes the reason for equipment failure can be seen right away and complete teardown is not necessary. Disassemble equipment only as far as necessary to repair or replace damaged parts.
- c. The following "Initial Setup" information applies to all procedures:
  - 1. Resources are not listed unless they apply to the procedure.
  - 2. "Personnel Required" is listed only if more than one technician is required to complete the task.
- d. All tags and forms attached to equipment must be checked to learn the reason for removal of equipment from service. Modification work orders and technical bulletins must also be checked for equipment changes and updates.
- e. In some cases, a part may be damaged by removal. If the part appears to be good and other parts behind it are not defective, leave it on and continue with the procedure. Here are a few simple rules:
  - 1. Do not remove dowel pins or studs unless loose, bent, broken, or otherwise damaged.
  - 2. Do not remove bearings or bushings unless damaged. If you need to remove them to access parts, carefully pull out bearings and bushings.
  - 3. Replace all gaskets, lockwashers, self-locking nuts, seals, cotter pins, preformed packings, and other locking hardware.

**4-18. WORK SAFETY.**

- a. Before beginning a procedure, think about the safety risks and hazards to yourself and others. Wear protective gear, such as safety goggles or lenses, safety shoes, rubber apron, and gloves.



---

**4-18. WORK SAFETY (continued).**

---

- b. Observe all WARNINGS and CAUTIONS.
- c. Clean up spilled fluids immediately, to avoid slipping.
- d. When lifting a heavy part, have someone help you. Make sure that lifting/jacking equipment is working properly, meets the weight requirement of the part being lifted, and is securely fastened to the part.
- e. Always use power tools carefully.
- f. All maintenance should be performed with
  - Trailer parking brake engaged;
  - Towing vehicle in neutral with parking brake engaged, if attached; and
  - Towing vehicle engine stopped, if attached.

---

**4-19. CLEANING INSTRUCTIONS.**

---

**WARNING**

**Improper cleaning methods and the use of unauthorized cleaning agents can injure personnel and damage equipment. To prevent this, refer to TM 9247 for instructions.**

- a. **General.** Cleaning instructions will be the same for the majority of parts and components that make up the trailer. The following applies to all cleaning operations:
  - 1. Clean all parts before inspection, after repair, and before assembly.
  - 2. Keep hands free of grease, which can collect dust, dirt, and grit.
  - 3. After cleaning, cover or wrap all parts to protect them from dust and dirt. Parts that are subject to rust should be lightly oiled.
- b. **Steam Cleaning.**

**WARNING**

**Avoid contact with live steam, which can burn skin, cause blindness, and cause other serious injury. Be sure to wear protective apron, gloves, and safety goggles around live steam.**

- 1. Before steam cleaning trailer, protect all electrical components that could be damaged by steam or moisture.
- 2. Place disassembled parts in a suitable container to steam-clean. Parts that are subject to rust should be dried and lightly oiled after cleaning.

---

**4-19. CLEANING INSTRUCTIONS (continued).**

---

**c. Castings, Forgings, and Machined Metal Parts.****WARNING**

Drycleaning solvent P-D-680 is toxic and flammable. Always wear protective goggles and gloves and use only in a well-ventilated area. Avoid contact with skin, eyes, and clothes, and DO NOT breathe vapors. DO NOT use near open flame or excessive heat.

1. Clean inner and outer surfaces with drycleaning solvent (Item 15, Appendix F).
2. Remove grease and accumulated deposits with a scrub brush (Item 1, Appendix F).

**WARNING**

Compressed air used for cleaning or drying purposes, or for clearing restrictions, should never exceed 30 psi (207 kPa). Wear protective clothing (goggles/shield, gloves, etc.) and use caution to avoid injury to personnel.

3. Clear out all threaded holes with compressed air to remove dirt and cleaning fluids.

**CAUTION**

DO NOT wash oil seals, electrical cables, and flexible hoses with drycleaning solvent or mineral spirits. Serious damage or destruction of material will result.

- d. **Oil Seals, Electrical Cables, and Flexible Hoses.** Wash electrical cables and flexible hoses with a solution of detergent (Item 5, Appendix F) and water and wipe dry.
- e. **Bearings.** Clean bearings in accordance with TM 9-214.

---

**4-20. INSPECTION INSTRUCTIONS.**

---

**NOTE**

All damaged areas should be marked for repair or replacement.

- a. All components and parts must be carefully checked to determine if they are serviceable, can be repaired, or must be scrapped.
- b. Inspect drilled and tapped (threaded) holes for the following:
  1. In or around holes-wear, distortion (stretching), cracks, and any other damage.
  2. Threaded areas-wear, distortion (stretching), and evidence of cross-threading.

---

**4-20. INSPECTION INSTRUCTIONS (continued).**

---

- c. Inspect metal lines, flexible lines (hoses), and metal fittings and connectors for the following:
  - 1. Metal lines-sharp kinks, cracks, bad bends, and dents.
  - 2. Flexible lines-fraying, evidence of leakage, and loose metal fittings or connectors.
  - 3. Metal fittings and connectors-thread damage and worn or rounded hex heads.
- d. Inspect castings, forgings, and machined metal parts for the following:
  - 1. Machined surfaces-nicks, burrs, raised metal, wear, and other damage.
  - 2. Inner and outer surfaces-breaks and cracks.
- e. Inspect fittings and connectors for leaks by coating fittings and connectors with solution of detergent (Item 5, Appendix F) and water. No leakage is permissible.
- f. Inspect bearings in accordance with TM 9-214.

---

**4-21. TAGGING PARTS.**

---

- a. Use marker tags (Item 16, Appendix F) to identify all electrical wires, hydraulic lines, and any other parts that may be hard to identify or replace later. Fasten a tag to the part during removal by wrapping a wire fastener around or through the part and twisting the ends together. Position tags to be out of the way during cleaning, inspection, and repair. Mark tags with a pencil, pen, or marker.
- b. Whenever possible, identify each electrical wire with the number of the terminal or wire to which it connects. If no markings can be found, tag both wires or wire and terminal using the same identifying mark for both. If you cannot tag a wire because it must fit through a small hole or you cannot reach it, write down a description of the wire and the point at which it connects or draw a simple diagram on paper. Be sure to write down enough information so you will be able to properly connect wires (or wire and terminal) during assembly. If you need to identify a loose wire, look for identifying numbers near the end of the wire, stamped on a permanent metal tag. Compare this number to the wire numbers on the wiring diagram (para 4-31).
- c. Identify and tag other parts as required by name and location.
- d. Remove all tags when finished.

---

**4-22. PRESERVATION OF PARTS.**

---

Unpainted metal parts that will not be installed immediately after cleaning should be covered with a thin coat of lubricating oil (Item 12, Appendix F).

---

**4-23. PAINTING.**

---

On areas where paint has been removed, paint in accordance with the procedures outlined in TM 43-0139 and TB 43-0209. For camouflage painting instructions, refer to FM 20-3.

---

**4-24. ELECTRICAL GROUND POINTS.**

---

Many electrical problems are the result of poor ground connections. You can ensure that ground connections are good by performing the following steps:

- a. Remove hardware connecting ground cable terminal lug to ground point.

**WARNING**

**Drycleaning solvent P-D-680 is toxic and flammable. Always wear protective goggles and gloves and use only in a well-ventilated area. Avoid contact with skin, eyes, and clothes, and DO NOT breathe vapors. DO NOT use near open flame or excessive heat.**

- b. Clean mounting hardware, mounting surfaces, ground terminal lug, and ground point with drycleaning solvent (Item 15, Appendix F) and scrub brush (Item 1, Appendix F).
- c. Remove any rust with wire brush (Item 2, Appendix F) and abrasive cloth (Item 3, Appendix F).
- d. Look for cracks, loose terminal lugs, and stripped threads. Replace any defective parts.
- e. Install hardware connecting ground cable terminal lug to ground point. Make sure all hardware is tight.

---

**4-25. HYDRAULIC BRAKE LINES AND PORTS.**

---

To keep dirt from contaminating the hydraulic brake system when removing and installing hydraulic brake lines, perform the following steps:

- a. Clean fittings and surrounding area before disconnecting lines.
- b. Cover lines and ports after disconnecting lines. Use hand-carved wooden plugs, clean rags (Item 13, Appendix F), duct tape (Item 18, Appendix F), or other similar materials to prevent dirt from entering system.
- c. Make sure new and used parts are clean before connecting.
- d. Wait to uncover lines and ports until just before connecting lines.

---

**4-26. FLUID DISPOSAL.**

---

Dispose of contaminated drained fluids in accordance with the SOP of your Unit.

**Section VI. ELECTRICAL SYSTEM MAINTENANCE**

Paragraph Number	Paragraph Title	Page Number
4-27	General.....	4-39
4-28	Composite Stoplight-Taillight Maintenance.....	4-39
4-29	Chassis Wiring Harness Replacement .....	4-43
4-30	Intervehicular Cable Replacement .....	4-46
4-31	Wiring Diagram .....	4-48

**4-27. GENERAL.**

This section describes and illustrates removal and installation procedures for the composite stoplight-taillight, chassis wiring harness, and Intervehicular cable.

**4-28. COMPOSITE STOPLIGHT-TAILLIGHT MAINTENANCE.**

*This task covers:*

- |  |   |
|--|---|
| a. Lamp/LED Removal                      | b. Lamp/LED Installation                      |
| c. Composite Stoplight-Taillight Removal | d. Composite Stoplight-Taillight Installation |

Initial Setup:

**Tools/Test Equipment:**

- General mechanic's tool kit (Item 1, Appendix B)

- Starwasher (2), MS45904-76

**Materials/Parts:**

- Tag, marker (as needed) (Item 16, Appendix F)
- Lockwasher (2), MS35338-46

**Equipment Conditions:**

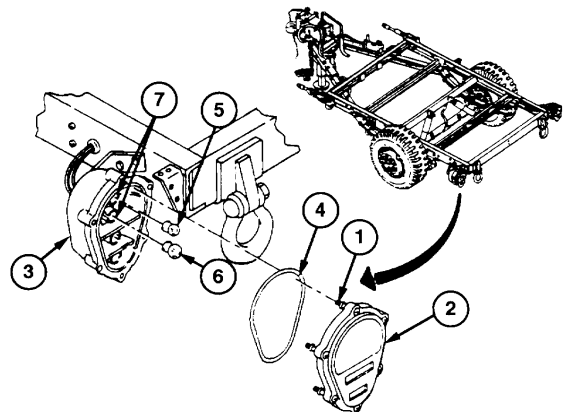
- Intervehicular cable disconnected from towing vehicle (para 2-15).

**a. LAMP/LED REMOVAL**

**NOTE**

Both 12 V dc and 24 V dc lamps are available. If towing vehicle is a CUCV, 12 V dc lamps should be used.

1. Loosen six captive screws (1), and remove lens (2) from body (3).
2. Inspect preformed packing (4) for damage. If damaged, remove preformed packing (4) and discard.
3. Remove two lamps (5 and 6) from sockets (7) by pushing in and turning counterclockwise.



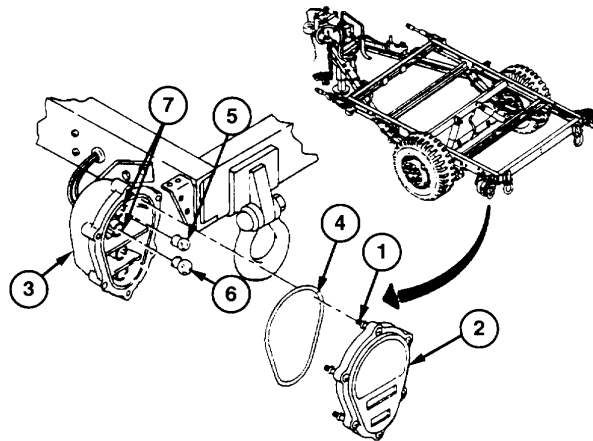
**4-28. COMPOSITE STOPLIGHT-TAILLIGHT MAINTENANCE (continued).****NOTE**

- If lamps are present, perform step 4.
- If LEDs are present, perform steps 5 and 6.

4. Remove two lamps (8) from sockets (9) by pushing in and turning counterclockwise.
5. Insert small flat-tipped screwdriver into slot inside center hole in LED (10). Push in firmly, turn counterclockwise, and remove LED (10) from socket (9).
6. Insert small flat-tipped screwdriver into slot on left side of LED (11) and open LED cover, allowing access to inside slot in center hole. Push in firmly with screwdriver in center hole slot, turn counterclockwise slightly, and remove LED (11) from socket (9).

**NOTE**

- LEDs can be used to replace lamps that were removed.
- To install LEDs, perform step 7.
- To install lamps, perform step 8.



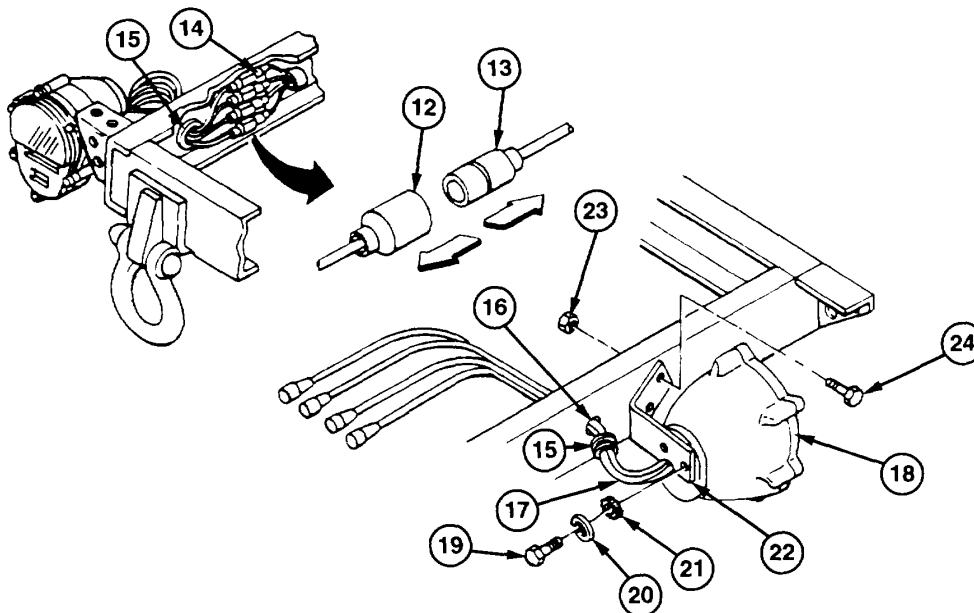
**4-28. COMPOSITE STOPLIGHT-TAILLIGHT MAINTENANCE (continued).****b. LAMP/LED INSTALLATION**

1. Install two LEDs (10 and 11) in sockets (9) by snapping into place by hand.
2. Install two lamps (8) in sockets (9) by pushing in and turning clockwise.
3. Install two lamps (5 and 6) in sockets (7) by pushing in and turning clockwise.
4. If removed, install new preformed packing (4) in lens (2).
5. Install lens (2) on body (3) and tighten six captive screws (1).

**c. COMPOSITE STOPLIGHT-TAILLIGHT REMOVAL****NOTE**

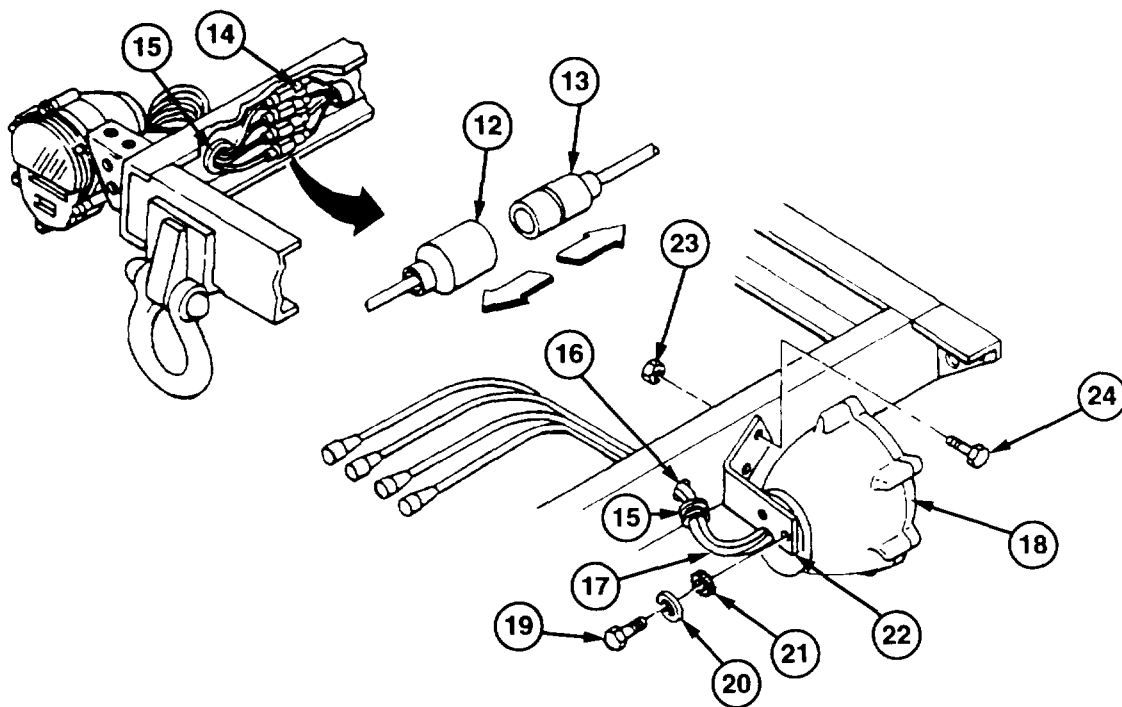
If marker bands are missing or illegible, tag wires for installation purposes (para 4-21).

1. Remove four composite stoplight-tailight connectors (12) and chassis wiring harness connectors (13) from clip (14) and disconnect connectors (12 and 13).
2. Remove grommet (15) from hole (16) in frame.
3. Pull four wires (17) of composite stoplight-tailight (18) through hole (16) in frame.
4. Remove two capscrews (19), lockwashers (20), and washers (21) and composite stoplight-tailight (18) from bracket (22). Discard lockwashers and washers.
5. If bracket (22) is damaged, remove two self-locking nuts (23) and capscrews (24) and bracket (22) from frame.



**4-28. COMPOSITE STOPLIGHT-TAILLIGHT MAINTENANCE (continued).****d. COMPOSITE STOPLIGHT-TAILLIGHT INSTALLATION**

1. If bracket (22) is removed, install bracket (22) on frame with two capscrews (24) and new self-locking nuts (23).
2. Install composite stoplight-taillight (18) on bracket (22) with two new washers (21), new lockwashers (20), and capscrews (19).
3. Feed four wires (17) of composite stoplight-taillight (18) through hole (16) in frame.
4. Position grommet (15) around four wires (17), and install grommet (15) through hole (16) in frame.
5. Connect four composite stoplight-taillight connectors (12) on four chassis wiring harness connectors (13). Place connectors (12 and 13) in clip (14).

**FOLLOW-ON TASKS:**

- Connect intervehicular cable to towing vehicle (para 2-13).



**4-29. CHASSIS WIRING HARNESS REPLACEMENT.***This Task Covers:*

a. Removal

b. Installation

Initial Setup:

**Tools/Test Equipment:**

- General mechanic's tool kit (Item 1, Appendix B)

**Materials/Parts:**

- Tag, marker (as needed) (Item 16, Appendix F)
- Lockwasher, MS35338-43
- Lockwasher (5), MS45904-64 (M116A2E1 and M 116A3)

- Lockwasher (15), MS45904-64 (M101A2, M101A3, and M116A2)
- Strap, tiedown, electrical (2), MS3367-1-9

**Equipment Conditions:**

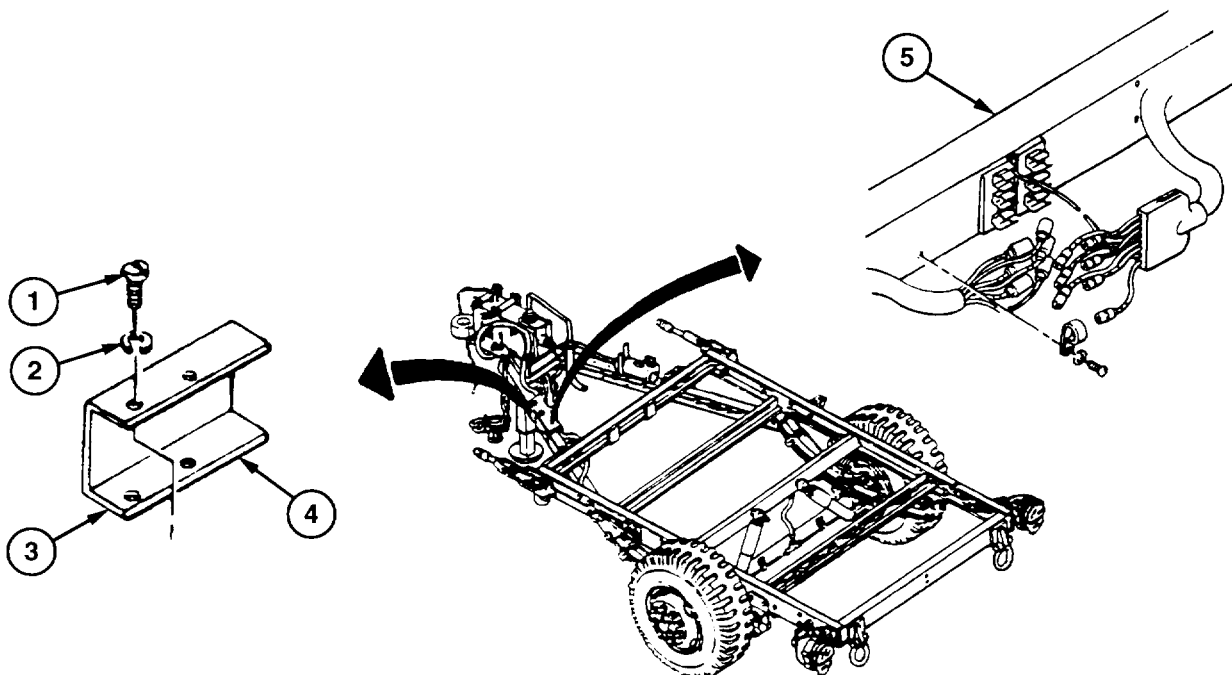
- Intervehicular cable disconnected from towing vehicle (para 2-15).

**NOTE**

Configuration of chassis wiring harness varies slightly with model. The M116A2 chassis trailer is shown.

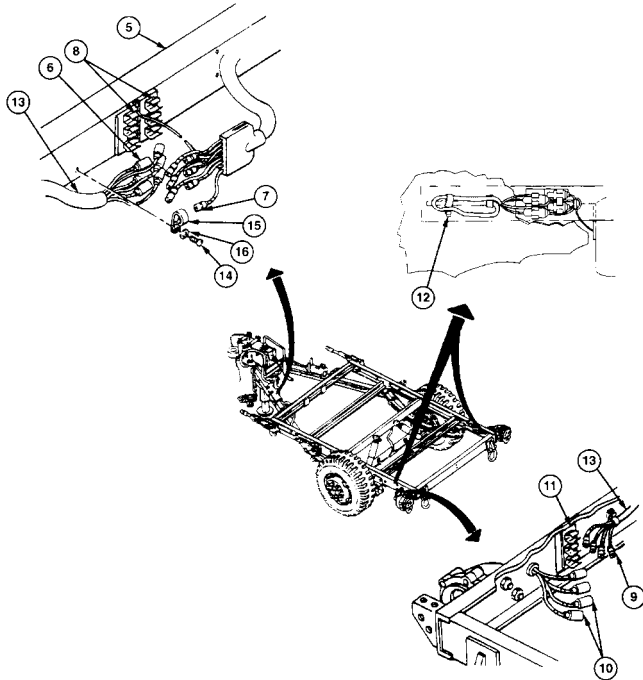
**a. REMOVAL**

1. Remove four screws (1) and lockwashers (2) and cover (3) from junction box (4) at road-side drawbar (5). Discard lockwashers.



**4-29. CHASSIS WIRING HARNESS REPLACEMENT (continued).****NOTE**

If marker bands are missing or illegible, tag wires for installation purposes (para 4-21).



2. At junction box at road-side drawbar (5), remove chassis wiring harness connectors (6) and intervehicular cable connectors (7) from clips (8) and disconnect connectors (6 and 7).
3. At curb-side and road-side rear of trailer, remove chassis wiring harness connectors (9) and light connectors (10) from clips (11) and disconnect connectors (9 and 10).
4. Remove electrical tiedown straps (12) from chassis wiring harness (13). Discard tiedown straps.

**NOTE**

The M116A2E1 and the M116A3 have no lockwashers at loop clamp mountings on rear crossmember and road-side frame. A lockwasher is used at loop clamp mounting on road-side drawbar.

5. Remove 11 screws (14) and lockwashers (15) from 11 loop clamps (16) securing chassis wiring harness (13) to rear crossmember, road-side frame, and road-side drawbar (5). Discard lockwashers.

**4-29. CHASSIS WIRING HARNESS REPLACEMENT (continued).**

6. At front road-side corner of frame, remove nut (17), screw (18), and lockwasher (19) from loop clamp (20) and frame. Discard lockwasher.
7. Remove chassis wiring harness (13) from frame. Remove 11 loop clamps (16) and loop clamp (20) from chassis wiring harness (13).

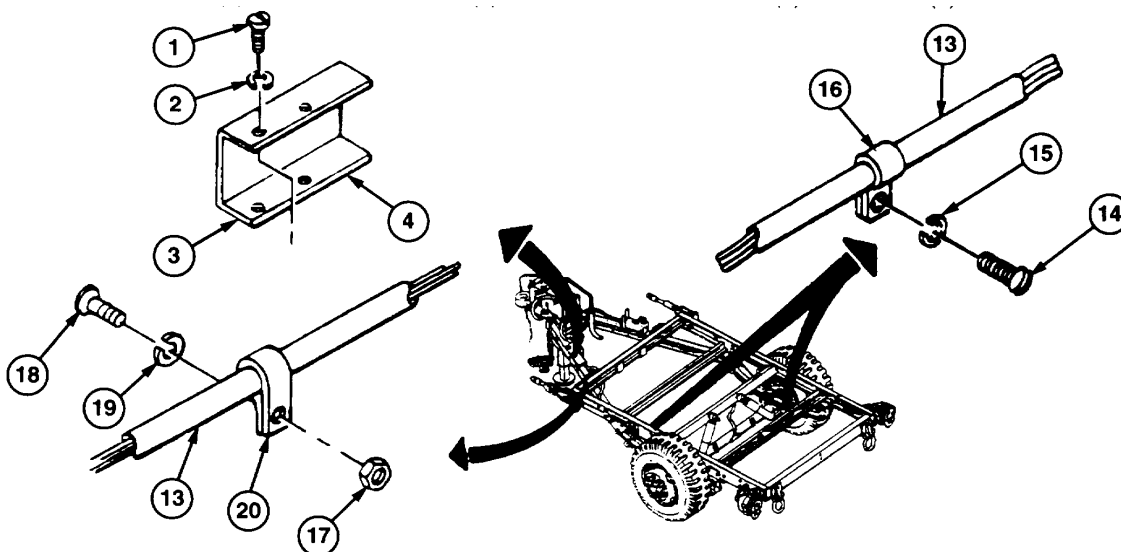
**b. INSTALLATION**

1. Position chassis wiring harness (13) along rear crossmember, road-side frame, and road-side drawbar (5). Make sure chassis wiring harness connectors (6 and 9) reach their points of connection. 2. At front road-side corner of frame, install loop clamp (20) on frame with new lockwasher (19), screw (18), and nut (17).

**NOTE**

The M116A2E1 and the M116A3 have no lockwashers at loop clamp mountings on rear crossmember and road-side frame. A lockwasher is used at loop clamp mounting on road-side drawbar.

3. Install 11 loop clamps (16) securing chassis wiring harness (13) to rear crossmember, road-side frame, and road-side drawbar (5) with 11 new lockwashers (15) and screws (14).
4. Loop excess chassis wiring harness (13) and secure with new electrical tiedown straps (12).
5. At curb-side and road-side rear of trailer, connect chassis wiring harness connectors (9) to light connectors (10). Place connectors (9 and 10) in clips (11).
6. At junction box (4) at road-side drawbar (5), connect chassis wiring harness connectors (6) to intervehicular cable connectors (7). Place connectors (6 and 7) in clips (8).
7. Install cover (3) on road-side drawbar (5) with four new lockwashers (2) and screws (1).



**FOLLOW-ON TASKS:**

- Connect intervehicular cable to towing vehicle (para 2-13).

**4-30. INTERVEHICULAR CABLE REPLACEMENT.**

*This Task Covers:*

a. Removal

b. Installation

Initial Setup:

**Tools/Test Equipment:**

- General mechanic's tool kit (Item 1, Appendix B)

- Self-locking nut, MS51922-21

**Materials/Parts:**

- Tag, marker (as needed) (Item 16, Appendix F)
- Lockwasher (7), MS45904-64

**Equipment Conditions:**

- Intervehicular cable disconnected from towing vehicle (para 2-15).

**NOTE**

Configuration of intervehicular cable and mounting varies slightly with model.

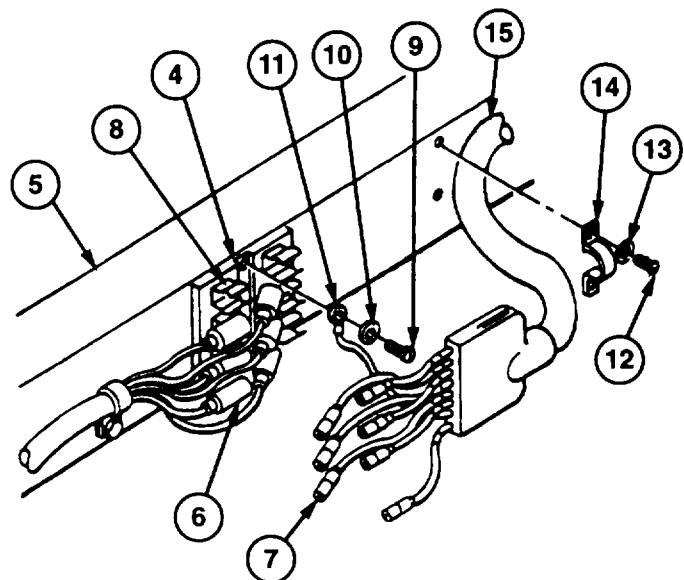
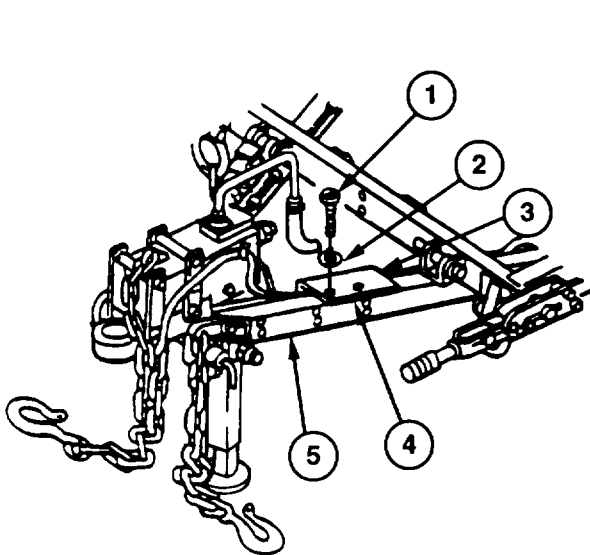
**a. REMOVAL**

1. Remove four screws (1) and lockwashers (2) and cover (3) from junction box (4) at road-side drawbar (5). Discard lockwashers.

**NOTE**

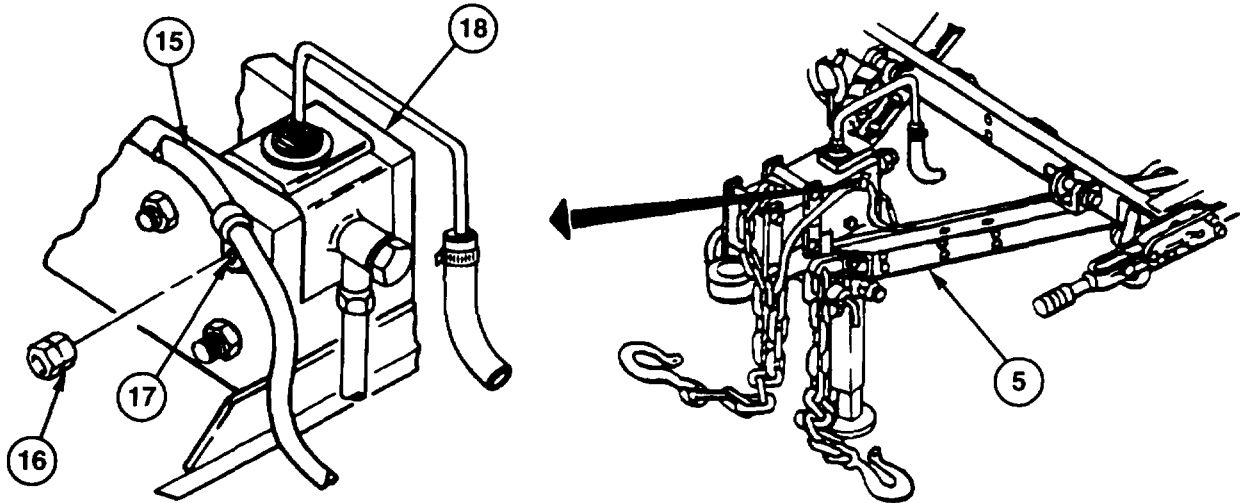
If marker bands are missing or illegible, tag wires for installation purposes (para 4-21).

2. At junction box (4) at road-side drawbar (5), remove chassis wiring harness connectors (6) and intervehicular cable connectors (7) from clips (8) and disconnect connectors (6 and 7).
3. Remove screw (9), lockwasher (10), and ground terminal (11) from road-side drawbar (5). Discard lockwasher.
4. Remove two screws (12) and lockwashers (13) and retaining strap (14) from intervehicular cable (15) and road-side drawbar (5). Discard lockwashers.



**4-30. INTERVEHICULAR CABLE REPLACEMENT (continued).**

5. Remove self-locking nut (16) and loop clamp (17) from hydraulic brake actuator assembly (18). Remove loop clamp (17) from intervehicular cable (15). Discard self-locking nut.

**b. INSTALLATION**

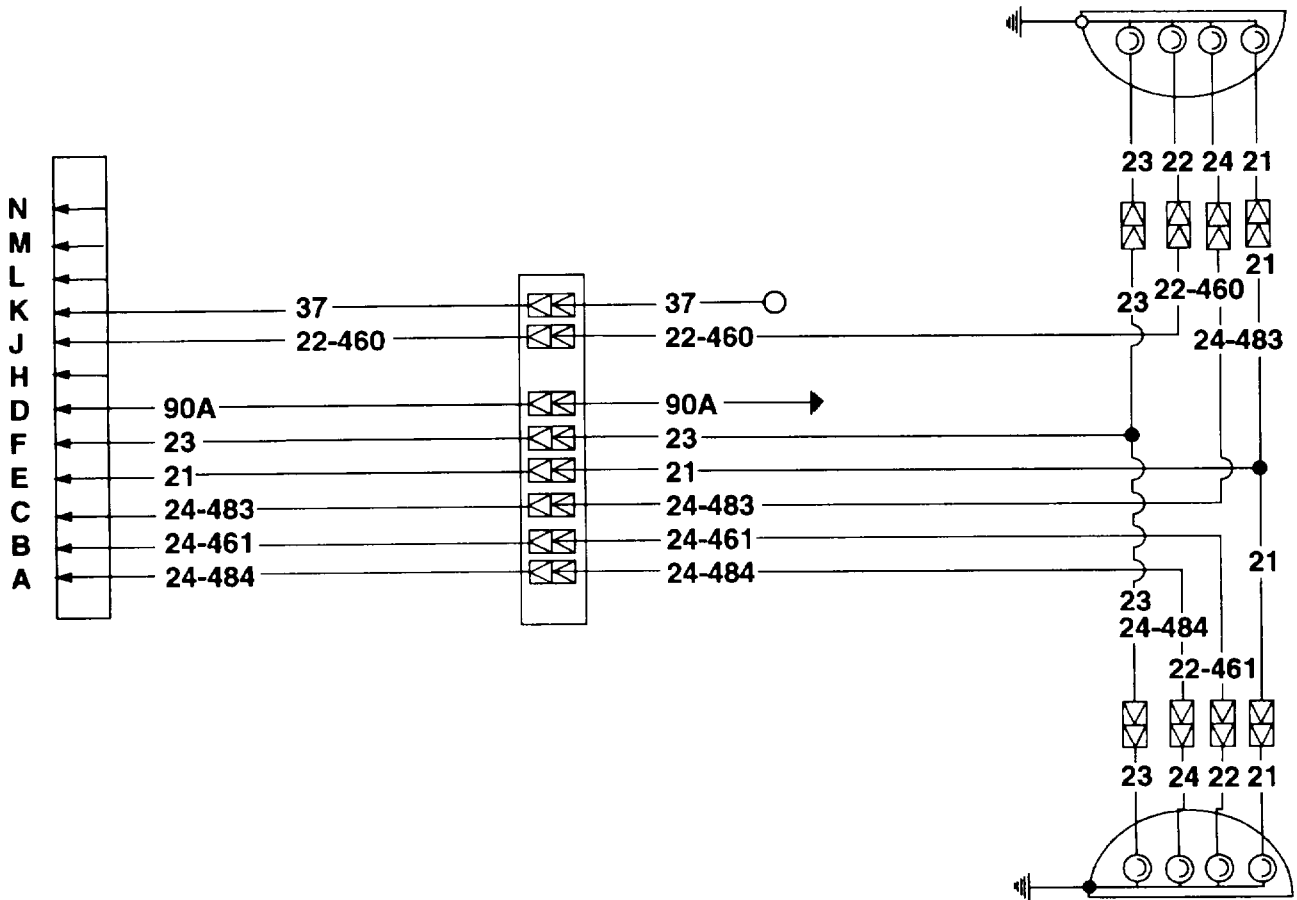
1. Position intervehicular cable (15) along road-side drawbar (5).
2. Install ground terminal (11) on drawbar (5) with new lockwasher (10) and screw (9).
3. Connect chassis wiring harness connectors (6) to intervehicular cable connectors (7). Place connectors (6 and 7) in clips (8).
4. Install retaining strap (14) on intervehicular cable (15) and road-side drawbar (5) with two new lockwashers (13) and screws (12).
5. Install loop clamp (17) on intervehicular cable (15). Install loop clamp (17) on hydraulic brake actuator assembly (18) with new self-locking nut (16).
6. Install cover (3) on junction box (4) at road-side drawbar (5) with four new lockwashers (2) and screws (1).

**FOLLOW-ON TASKS:**

- Connect intervehicular cable to towing vehicle (para 2-13).

**4-31. WIRING DIAGRAM.**

This wiring diagram is for the chassis wiring harness. Refer to this wiring diagram when performing troubleshooting or maintenance on the electrical system of the M101 and M116 Series trailers.



Curb-Side Circuits		Road-Side Circuits	
22-460	Service Stoplight and Turn Signal	22-461	Service Stoplight and Turn Signal
23	Blackout Stoplight	23	Blackout Stoplight
24-483	Blackout Taillight and Turn Signal	24-484	Blackout Taillight and Turn Signal
21	Service Taillight	21	Service Taillight

**Section VII. BRAKE SYSTEM MAINTENANCE**

<b>Paragraph Number</b>	<b>Paragraph Title</b>	<b>Page Number</b>
4-32	General.....	4-49
4-33	Handbrake Lever and Linkage Replacement.....	4-49
4-34	Handbrake Adjustment.....	4-54
4-35	Service Brake Maintenance .....	4-55
4-36	Service Brake Adjustment .....	4-60
4-37	Wheel Cylinder Replacement.....	4-61
4-38	Hydraulic Brake Actuator Assembly Replacement.....	4-63
4-39	Master Cylinder Replacement .....	4-73
4-40	Hydraulic Brake Lines Replacement .....	4-76
4-41	Bleeding Hydraulic Brake System.....	4-81

**4-32. GENERAL.**

This section describes and illustrates replacement, adjustment, and maintenance of the handbrake and hydraulic brake system.

**4-33. HANDBRAKE LEVER AND LINKAGE REPLACEMENT.**

*This Task Covers:*

- |                 |                            |
|-----------------|----------------------------|
| a. Removal      | b. Cleaning and Inspection |
| c. Installation |                            |

Initial Setup:

**Tools/Test Equipment:**

- General mechanic's tool kit (Item 1, Appendix B)
- Self-locking nut (3), MS21042-5
- Self-locking nut, MS21042-6

**Materials/Parts:**

- Rag (Item 13, Appendix F)
- Solvent, drycleaning (Item 15, Appendix F)

**Equipment Conditions:**

- Handbrakes released (para 2-10).
- Hub and brakedrum removed (para 4-43).

**WARNING**

**When performing maintenance on brake system, make sure wheels are securely chocked. Failure to follow this warning may cause trailer to roll, resulting in serious injury or death to personnel or damage to equipment.**

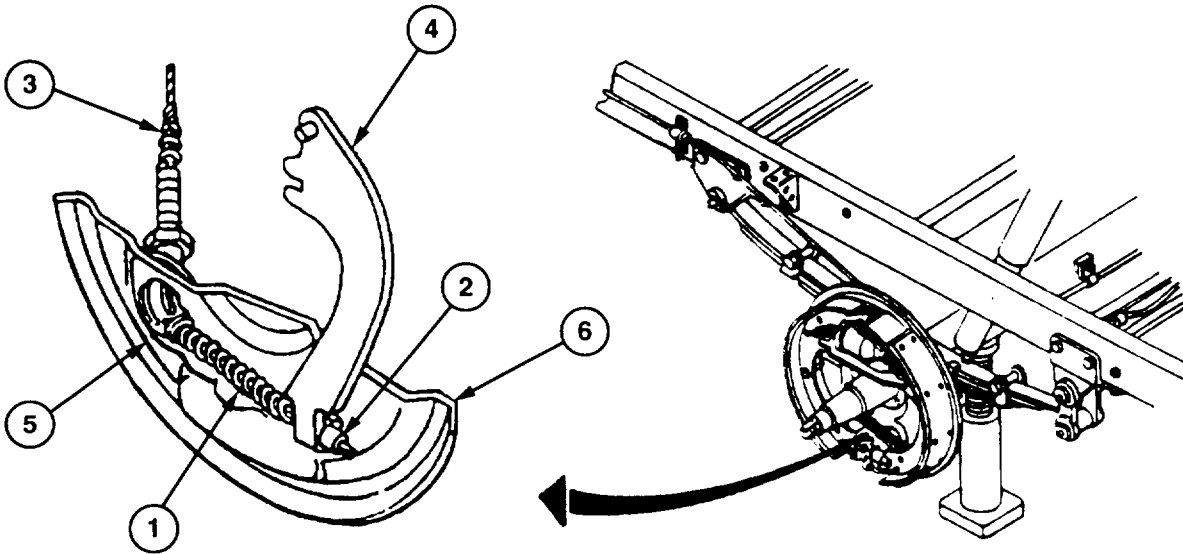
---

**4-33. HANDBRAKE LEVER AND LINKAGE REPLACEMENT (continued).**

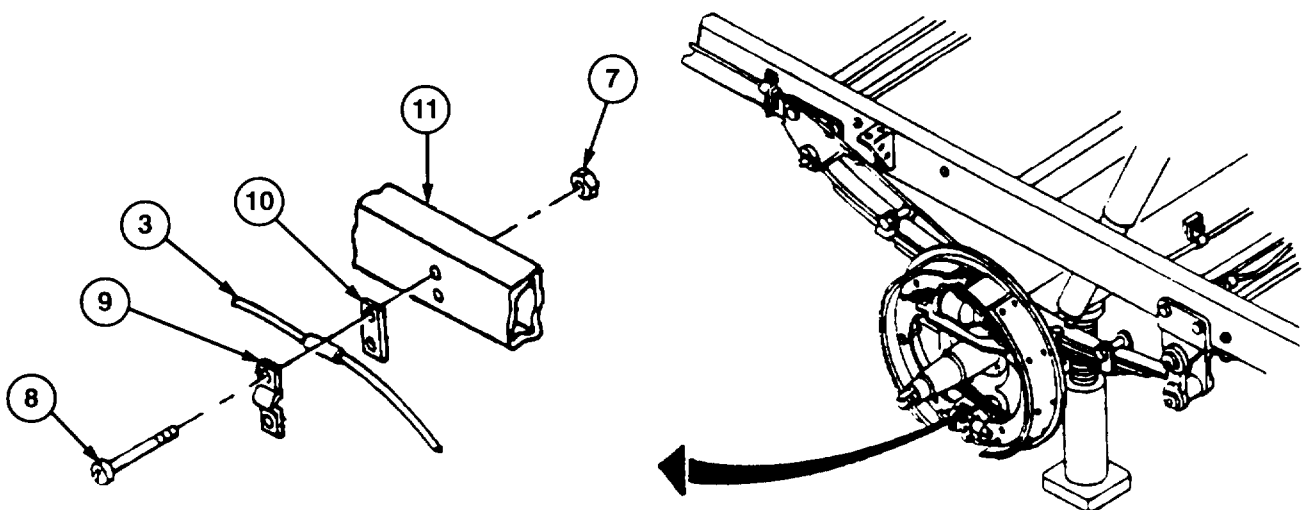

---

**a. REMOVAL**

1. At wheel brake, pull spring (1) away from swaged sleeve (2) and unhook swaged sleeve (2) of cable assembly (3) from handbrake lever (4).



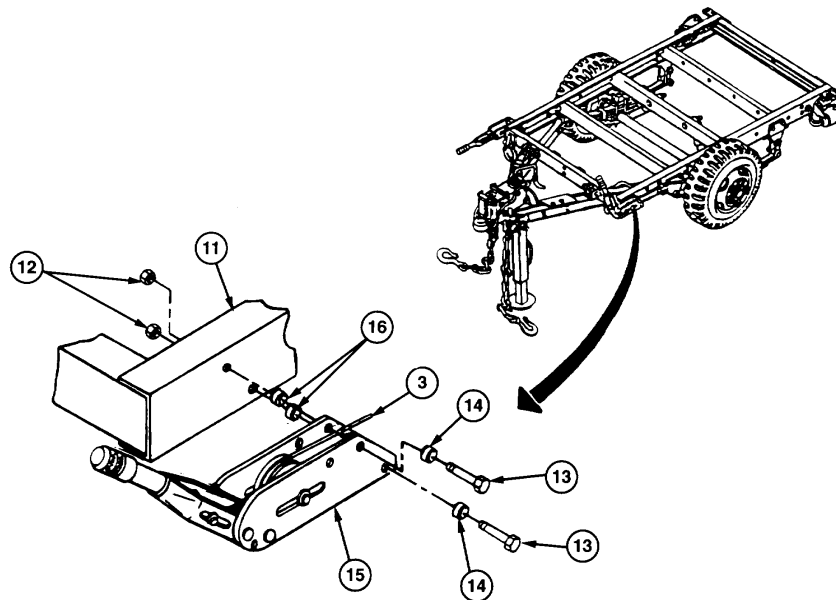
2. Compress lock tangs (5).
3. Remove cable assembly (3) from handbrake lever (4) through backing plate (6).
4. Remove two self-locking nuts (7) and machine screws (8), retaining strap (9), cable assembly (3), and spacer plate (10) from frame (11). Discard self-locking nuts.





**4-33. HANDBRAKE LEVER AND LINKAGE REPLACEMENT (continued).**

5. Remove two self-locking nuts (12), capscrews (13), and spacers (14), handbrake lever (15), and two washers (16) from frame (11). Discard self-locking nuts.
6. Disconnect cable assembly (3) from handbrake lever (15).
7. Repeat steps 1 through 6 for removal of other handbrake lever and linkage.

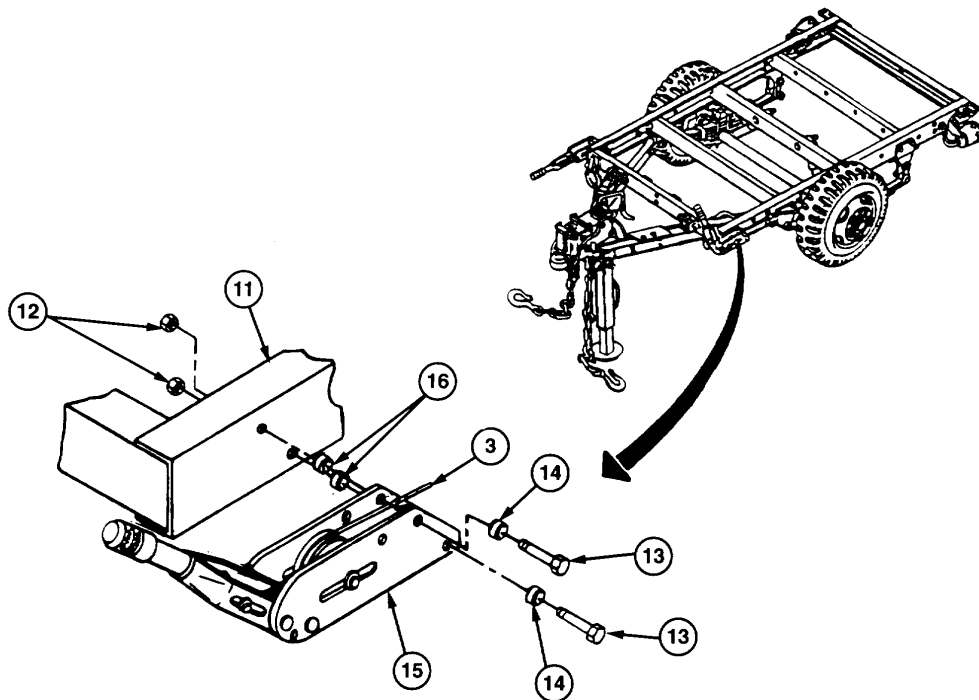
**b. CLEANING AND INSPECTION****WARNING**

**Drycleaning solvent P-D-680 is toxic and flammable. Always wear protective goggles and gloves, and use only in a well-ventilated area. Avoid contact with skin, eyes, and clothes, and DO NOT breathe vapors. DO NOT use near open flame or excessive heat.**

1. Clean all removed components with drycleaning solvent and rag and allow to dry.
2. Inspect handbrake lever for bends, breaks, corrosion, and freedom of action. Replace handbrake lever if damaged.
3. Inspect cable assembly for frays, cracks, distortion, corrosion, and freedom of movement in conduit. Replace cable assembly if damaged.
4. Inspect all mounting hardware for damage. Replace if damaged.

**4-33. HANDBRAKE LEVER AND LINKAGE REPLACEMENT (continued).****c. INSTALLATION**

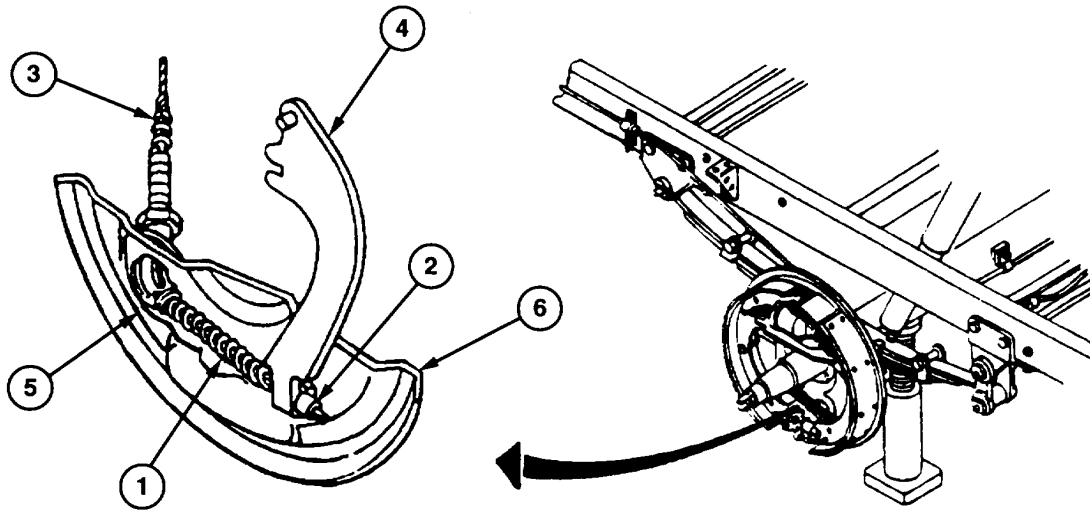
1. Connect cable assembly (3) to handbrake lever (15).
2. Position two washers (16) at frame (11) and install handbrake lever (15) with two spacers (14), capscrews (13), and new self-locking nuts (12).

**CAUTION**

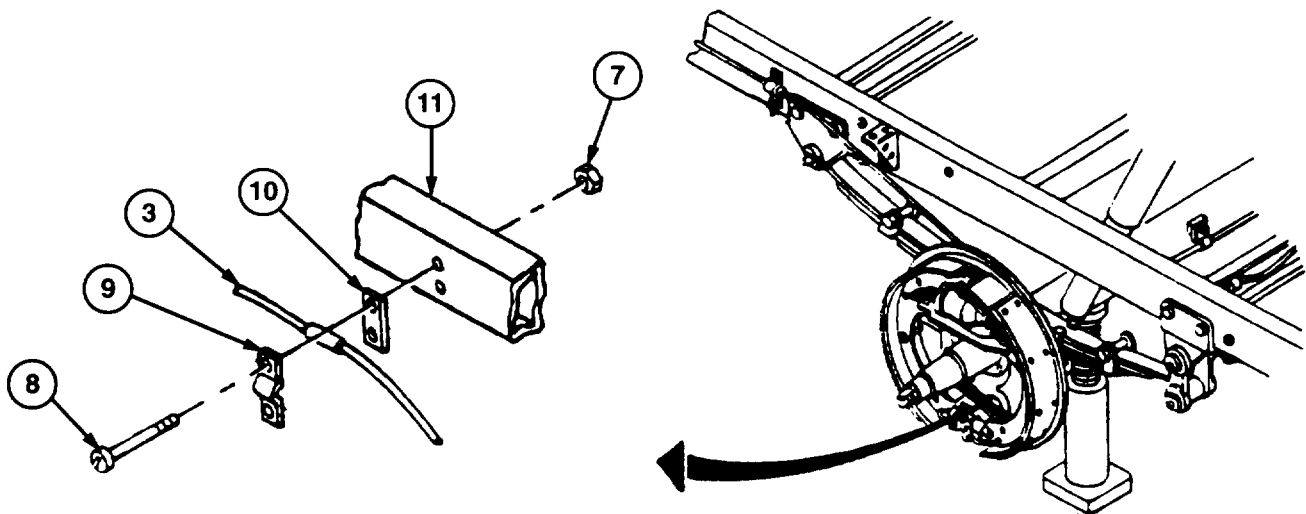
**Cable must be positioned below top spacer. To do otherwise causes cable to jump off pulley, resulting in damage to cable.**

3. Feed cable assembly (3) through backing plate (6) and position at handbrake lever (4).
4. Make sure lock tangs (5) are spread and hold cable assembly (3) in backing plate (6).
5. Pull spring (1) away from swaged sleeve (2), and hook swaged sleeve (2) to handbrake lever (4).

4-33. HANDBRAKE LEVER AND LINKAGE REPLACEMENT (continued).



6. Install spacer plate (10), cable assembly (3), and retaining strap (9) on frame (11) with two machine screws (8) and new self-locking nuts (7).
7. Repeat steps 1 through 6 for installation of other handbrake lever and linkage.



**FOLLOW-ON TASKS:**

- Install hub and brakedrum (para 4-43).
- Install wheel and tire assembly (para 4-44).
- Lubricate handbrake lever and linkage (Appendix I).
- Adjust handbrakes (para 4-34).

**4-34. HANDBRAKE ADJUSTMENT.***This Task Covers:*

Adjustment

Initial Setup:

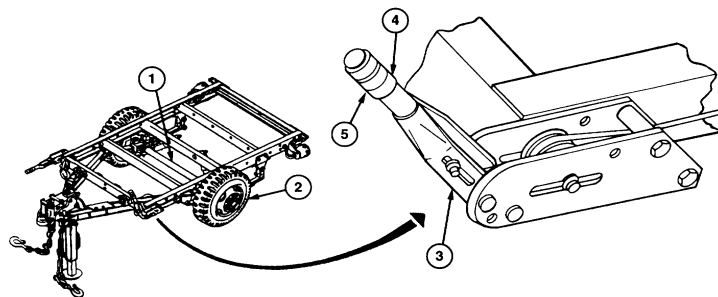
**Tools/Test Equipment:**

- General mechanic's tool kit (Item 1, Appendix B)
- Common No. 1 tool set (Item 2, Appendix B)

**ADJUSTMENT****WARNING**

**When performing maintenance on brake system, make sure wheels are securely chocked. Failure to follow this warning may cause trailer to roll, resulting in serious injury or death to personnel or damage to equipment.**

1. Chock wheels on side of trailer opposite side being adjusted.
2. Place floor jack under axle (1) on side where handbrake is to be adjusted. Raise axle (1) until wheel and tire assembly (2) is off the ground.
3. Release handbrake lever (3) on side to be adjusted.
4. Loosen lock screw (4) at adjusting knob (5).
5. Turn adjusting knob (5) clockwise until wheel and tire assembly (2) locks when handbrake lever (3) is no more than two-thirds applied.
6. Release handbrake lever (3) and make sure wheel and tire assembly (2) turns freely.
7. Fully tighten lock screw (4) at adjusting knob (5).
8. Lower axle (1).
9. Repeat steps 1 through 8 for other side.

**FOLLOW-ON TASKS:**

- None

---

**4-35. SERVICE BRAKE MAINTENANCE.**


---

*This Task Covers:*

- |                            |                |
|----------------------------|----------------|
| a. Removal                 | b. Disassembly |
| c. Cleaning and Inspection | d. Assembly    |
| e. Installation            |                |
- 

*Initial Setup:*

**Tools/Test Equipment:**

- |  |                              |
|--|------------------------------|
| • General mechanic's tool kit (Item 1, Appendix B) | • Clamp, 11686281            |
| • Common No. 1 tool set (Item 2, Appendix B)       | • Lockwasher, MS35335-34     |
|  | • Lockwasher (5), MS35338-46 |

**Materials/Parts:**

- Rag (Item 13, Appendix F)
- Solvent, drycleaning (Item 15, Appendix F)

**Equipment Conditions:**

- Hub and brakedrum removed (para 4-43).
- 

a. **REMOVAL**

**WARNING**

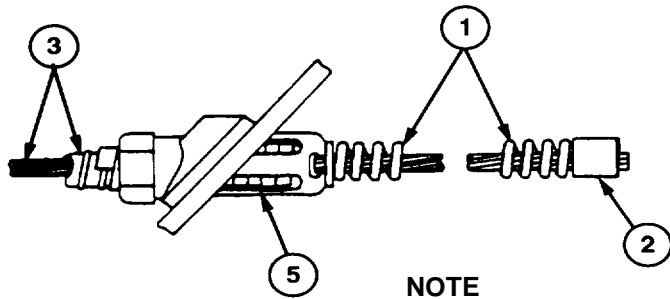
**DO NOT** handle brakeshoes, brakedrums, or other brake components unless area has been properly cleaned. Asbestos dust, which can be dangerous if you touch it or breathe it, may be on these components. Wear an approved filter mask and gloves. **NEVER** use compressed air or a dry brush to clean brake components. Dust may be removed using an industrial-type vacuum cleaner. Clean dust or mud away from brake components with water and a wet, soft brush or cloth. Failure to follow this warning may result in serious illness or death to personnel.

**NOTE**

It is not necessary to remove backing plate and service brake assembly from axle in order to disassemble service brake assembly. Disassembly may be performed with service brake assembly on axle or on work bench.

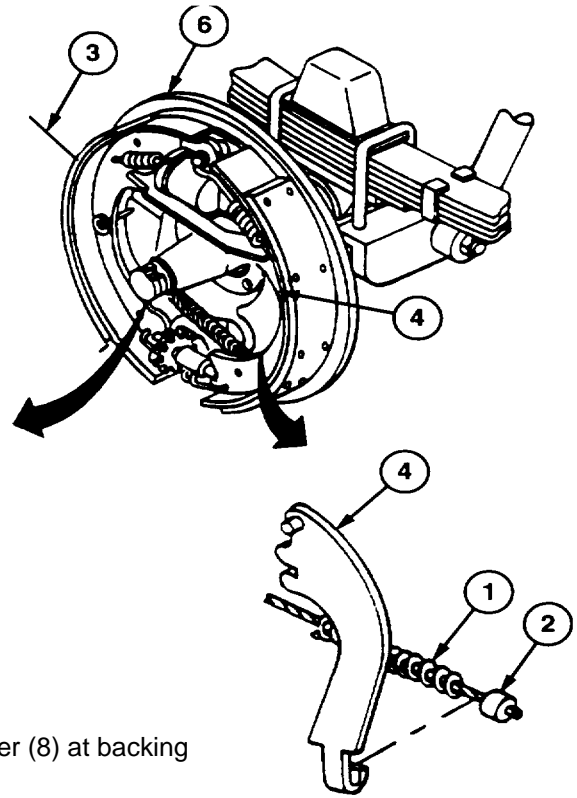
**4-35. SERVICE BRAKE MAINTENANCE (continued).**

1. At wheel brake, pull spring (1) away from swaged sleeve (2) and unhook swaged sleeve (2) of handbrake cable assembly (3) from lever (4).
2. Compress lock tangs (5).
3. Remove handbrake cable assembly (3) from lever (4) through backing plate (6).

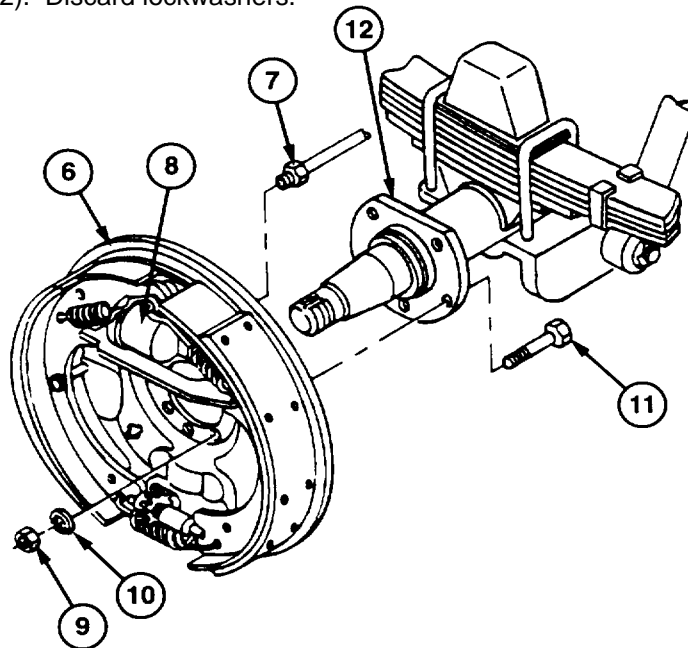


**NOTE**

Use a suitable container to catch any draining brake fluid. Make sure all spills are cleaned up.



4. Disconnect hydraulic tube assembly (7) from wheel cylinder (8) at backing plate (6).
5. Remove five nuts (9), lockwashers (10), and capscrews (11) and backing plate (6) from axle (12). Discard lockwashers.



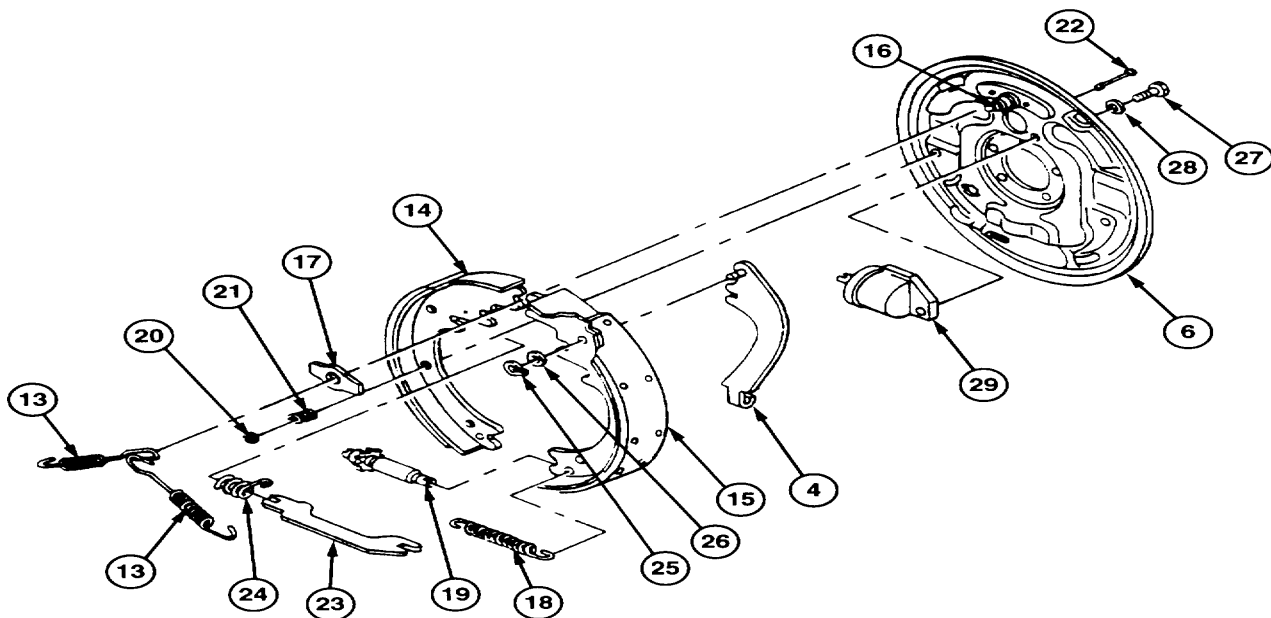
**4-35. SERVICE BRAKE MAINTENANCE (continued).****b. DISASSEMBLY**

1. Remove two springs (13) from two brakeshoes (14 and 15) and anchor pin (16). Remove plate (17) from anchor pin (16).
2. Remove spring (18) and adjusting screw (19) from two brakeshoes (14 and 15).
3. Remove two retainers (20), springs (21), and pins (22) from two brakeshoes (14 and 15) and backing plate (6).
4. Remove two brakeshoes (14 and 15), strut (23), and spring (24) from backing plate (6).
5. Remove clamp (25), spring tension washer (26), and lever (4) from brakeshoe (15). Discard clamp.
6. Remove bolt (27), lockwasher (28), and wheel cylinder (29) from backing plate (6). Discard lockwasher.

**c. CLEANING AND INSPECTION****WARNING**

**Drycleaning solvent P-D-680 is toxic and flammable. Always wear protective goggles and gloves, and use only in a well-ventilated area. Avoid contact with skin, eyes, and clothes, and DO NOT breathe vapors. DO NOT use near open flame or excessive heat.**

1. Clean all removed components with drycleaning solvent and rag and allow to dry.



**4-35. SERVICE BRAKE MAINTENANCE (continued).**

2. Inspect backing plate for cracks, breaks, corrosion, or other damage. Replace backing plate if damaged.

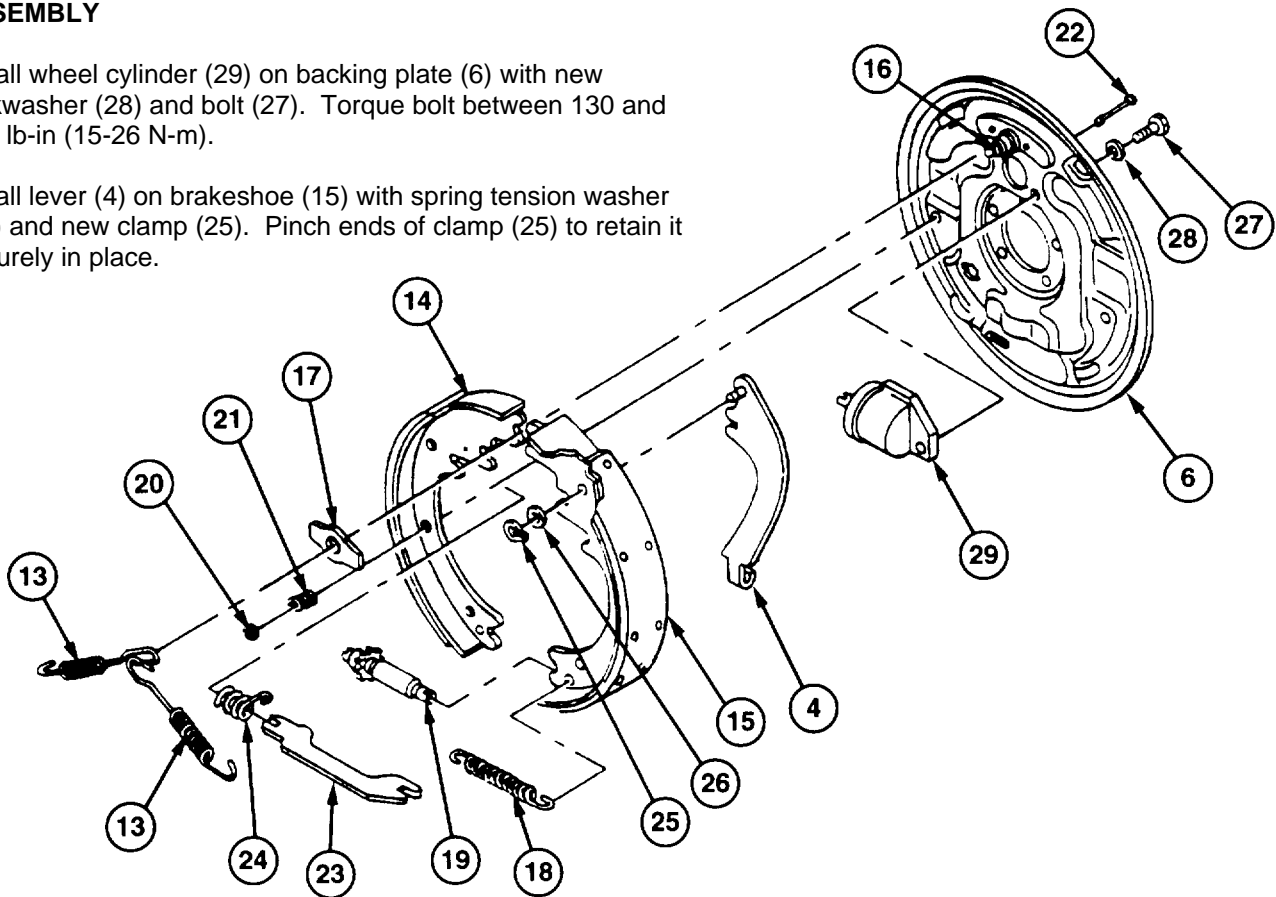
**WARNING**

**If one brakeshoe is being replaced, replace all brakeshoes on axle. Combination of old brakeshoes with new brakeshoes will cause uneven braking. Accidents causing serious injury or death to personnel or damage to equipment may result.**

3. Inspect brakeshoe linings for cracks or grease. Measure lining thickness. Lining thickness must be at least 1/8 inch (3.18 mm). Replace brakeshoes if damaged, grease soaked, or worn.
4. Inspect strut and lever for cracks and wear. Replace if damaged.
5. Inspect adjusting screw for corrosion or wear on teeth. Replace adjusting screw if corroded or worn.
6. Inspect wheel cylinder for leakage and corrosion. Replace if damaged.
7. Inspect all other removed components for cracks, breaks, distortion, corrosion, or other damage. Replace any damaged components.

**d. ASSEMBLY**

1. Install wheel cylinder (29) on backing plate (6) with new lockwasher (28) and bolt (27). Torque bolt between 130 and 230 lb-in (15-26 N-m).
2. Install lever (4) on brakeshoe (15) with spring tension washer (26) and new clamp (25). Pinch ends of clamp (25) to retain it securely in place.



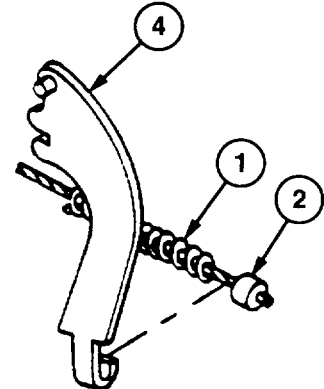
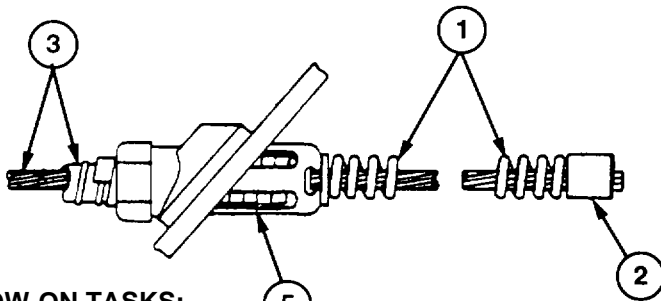
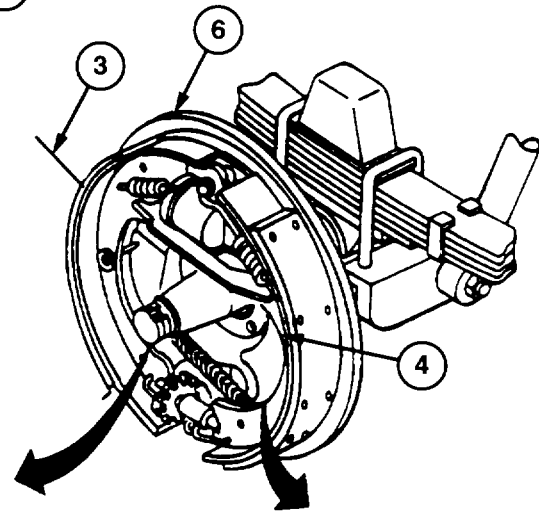
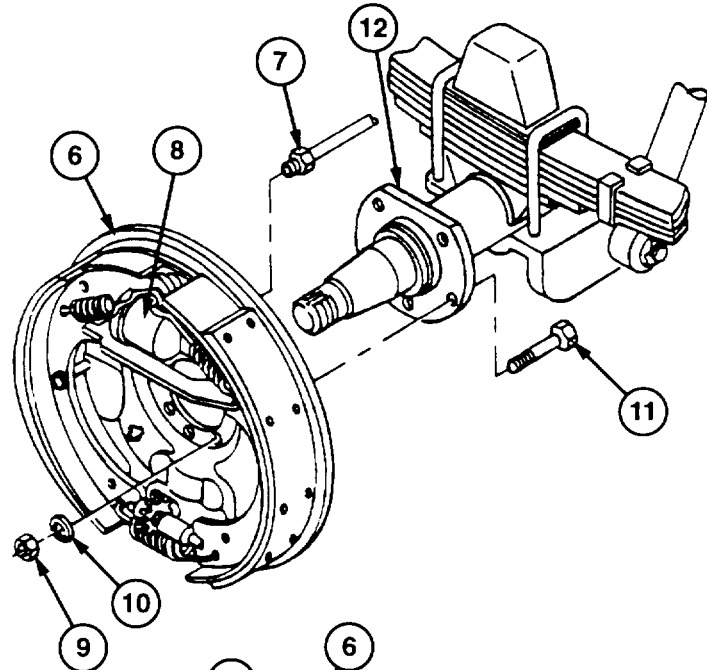


**4-35. SERVICE BRAKE MAINTENANCE (continued).**

3. Install two brakeshoes (14 and 15), pins (22), and springs (21) on backing plate (6). Install two retainers (20), spring (24), and strut (23) on backing plate (6).
4. Turn in adjusting screw (19) fully. Install adjusting screw (19) and spring (18) between two brakeshoes (14 and 15).
5. Install plate (17) on anchor pin (16).
6. Install two springs (13) on anchor pin (16) and brakeshoes (14 and 15).

**e. INSTALLATION**

1. Install backing plate (6) and service brake assembly on axle (12) with five capscrews (11), new lockwashers (10), and nuts (9).
2. Connect hydraulic tube assembly (7) to wheel cylinder (8) at backing plate (6).
3. Feed handbrake cable assembly (3) through backing plate (6) and position at lever (4). Make sure lock tangs (5) are spread and hold handbrake cable assembly (3) securely in backing plate (6).
4. Pull spring (1) away from swaged sleeve (2), and hook swaged sleeve (1) to lever (4).



**FOLLOW-ON TASKS:**

- Install hub and brakedrum (para 4-43).
- Install wheel and tire assembly (para 4-44).
- Bleed hydraulic brake system (para 4-41).
- Adjust service brakes (para 4-36).
- Adjust handbrakes (para 4-34).

---

**4-36. SERVICE BRAKE ADJUSTMENT.**

---

*This Task Covers:*Adjustment

---

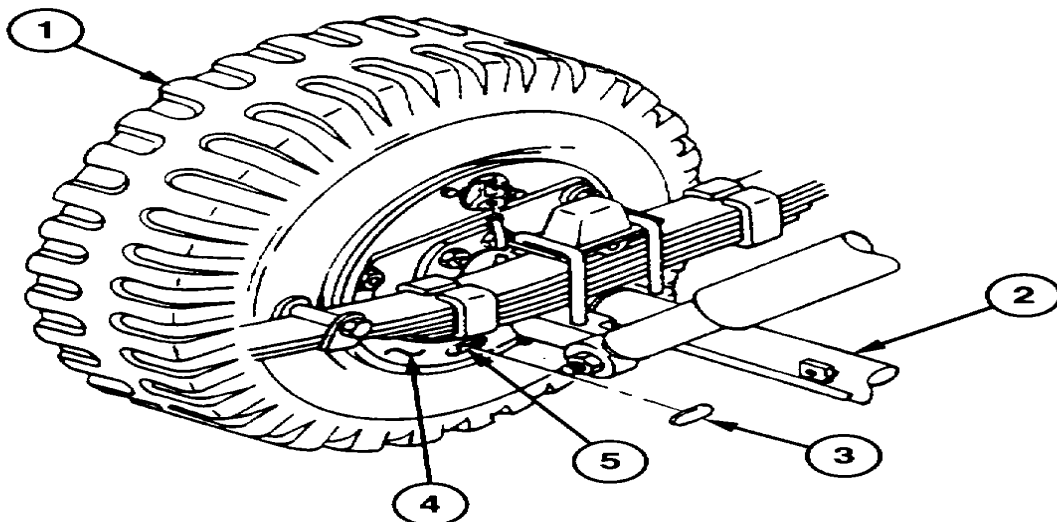
*Initial Setup:***Tools/Test Equipment:**

- General mechanic's tool kit (Item 1, Appendix B)
  - Common No. 1 tool set (Item 2, Appendix B)
- 

**ADJUSTMENT****NOTE**

The procedure for adjusting service brake is the same for left side and right side.

1. Apply handbrake (para 2-10). Chock wheel and tire assembly (1) opposite side of service brake being adjusted.
2. Raise axle (2) on side being adjusted until wheel and tire assembly (1) is off the ground.
3. Release handbrake on side being adjusted (para 2-10).
4. Remove cover (3) from backing plate (4).
5. While turning wheel and tire assembly (1), turn adjusting screw (5) until brakes drag lightly. Then turn adjusting screw (5) in opposite direction one click.
6. Install cover (3) in backing plate (4).
7. Lower axle (2). Apply handbrake on adjusted side (para 2-10).

**FOLLOW-ON TASKS:**

Adjust handbrakes (para 4-34).

**4-37. WHEEL CYLINDER REPLACEMENT.***This Task Covers:*

- |    |              |    |                         |
|----|--------------|----|-------------------------|
| a. | Removal      | b. | Cleaning and Inspection |
| c. | Installation |    |                         |

*Initial Setup:***Tools/Test Equipment:**

- General mechanic's tool kit (Item 1, Appendix B)
- Common No. 1 tool set (Item 2, Appendix B)
- Solvent, drycleaning (Item 15, Appendix F)
- Lockwasher, MS35335-34

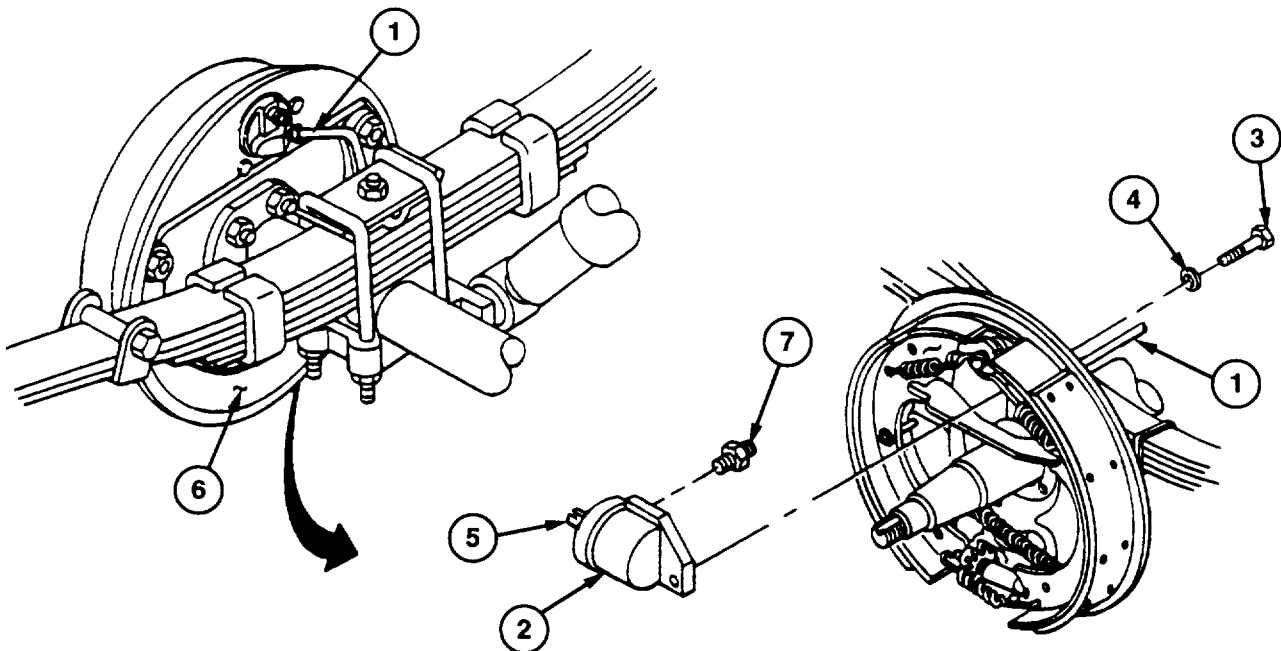
**Materials/Parts:-**

- Rag (Item 13, Appendix F)
- Equipment Conditions:**
- Hub and brakedrum removed (para 4-43).

**a. REMOVAL****NOTE**

- Use a suitable container to catch any draining brake fluid. Make sure all spills are cleaned up.
- If removing or replacing wheel cylinder, do steps 1 and 2 only. If removing or replacing bleeder valve only, do step 3 only.

1. Disconnect hydraulic brake tube assembly (1) at inlet to wheel cylinder (2).
2. Remove bolt (3), lockwasher (4), wheel cylinder (2), and link (5) from backing plate (6). Discard lockwasher.
3. Remove bleeder valve (7) from wheel cylinder (2).



**4-37. WHEEL CYLINDER REPLACEMENT (continued).****b. CLEANING AND INSPECTION****WARNING**

Drycleaning solvent P-D-680 is toxic and flammable. Always wear protective goggles and gloves, and use only in a well-ventilated area. Avoid contact with skin, eyes, and clothes, and DO NOT breathe vapors. DO NOT use near open flame or excessive heat.

1. Clean all removed components, except wheel cylinder, with drycleaning solvent and rag and allow to dry. Wipe wheel cylinder with a clean rag.
2. Inspect components for cracks, breaks, corrosion, or damaged threads. Replace if damaged.

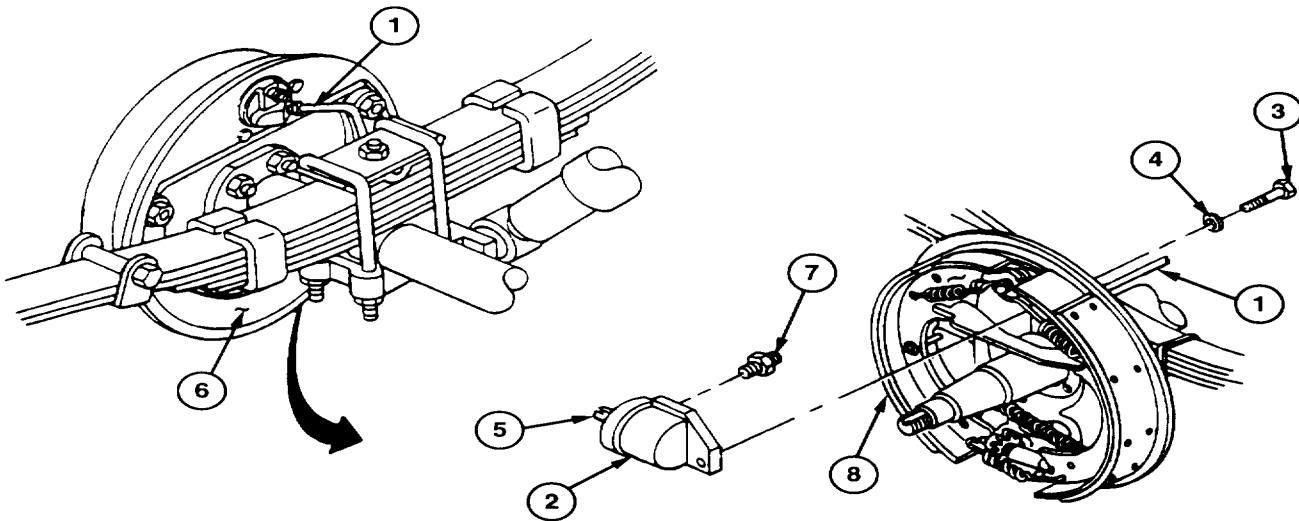
**c. INSTALLATION**

1. If removed, install bleeder valve (7) on wheel cylinder (2).

**CAUTION**

Make sure boot of wheel cylinder is dry before installing wheel cylinder. Failure to follow this caution may cause brake fluid to damage brakeshoe linings.

2. Assemble wheel cylinder (2) and link (5) at backing plate (6), with link engaged in primary brakeshoe (8). Install new lockwasher (4) and bolt (3) on wheel cylinder (2). Torque bolt between 130 and 280 lb-in (15-26 Nom).
3. Connect hydraulic brake tube assembly (1) to inlet of wheel cylinder (2).

**FOLLOW-ON TASKS:**

- Install hub and brakedrum (para 4-43).
- Install wheel and tire assembly (para 4-44).
- Bleed hydraulic brake system (para 4-41).
- Adjust service brake (para 4-36).
- Adjust handbrakes (para 4-34).

**4-38. HYDRAULIC BRAKE ACTUATOR ASSEMBLY REPLACEMENT.***This Task Covers:*

- |                            |                |
|----------------------------|----------------|
| a. Removal                 | b. Disassembly |
| c. Cleaning and Inspection | d. Assembly    |
| e. Installation            |                |

*Initial Setup:***Tools/Test Equipment:**

- General mechanic's tool kit (Item 1, Appendix B)
- Common No. 1 tool set (Item 2, Appendix B)

**Materials/Parts:**

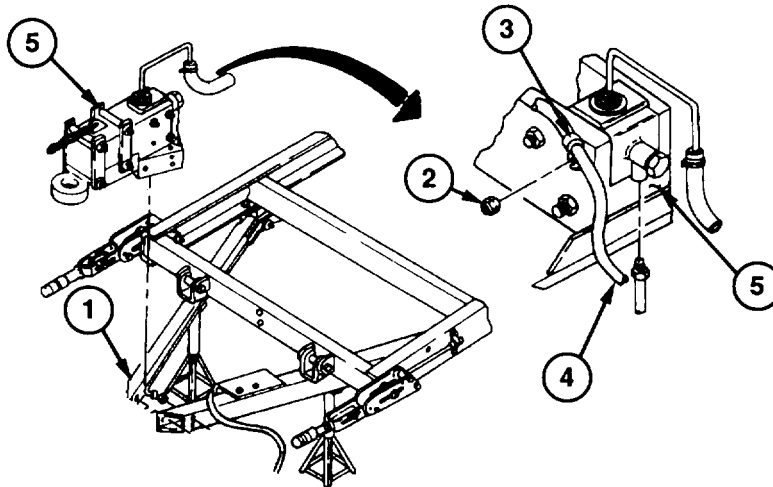
- Brush, wire (Item 2, Appendix F)
- Detergent (Item 5, Appendix F)
- Rag (Item 13, Appendix F)
- Solvent, drycleaning (Item 15, Appendix F)
- Lockwasher (4), 210104-8S
- Self-locking nut (8), MS21044N8
- Self-locking nut, MS21083-C7
- Self-locking nut (3), MS51922-21
- Self-locking nut (6), MS51922-29
- Self-locking nut (3), MS51922-61

**a. REMOVAL**

1. Place jackstand under drawbar (1) at each front corner of frame.
2. Remove self-locking nut (2) and loop clamp (3), with intervehicular cable (4) from hydraulic brake actuator assembly (5). Discard self-locking nut.

**NOTE**

Use a suitable container to catch any draining brake fluid. Make sure all spills are cleaned up.



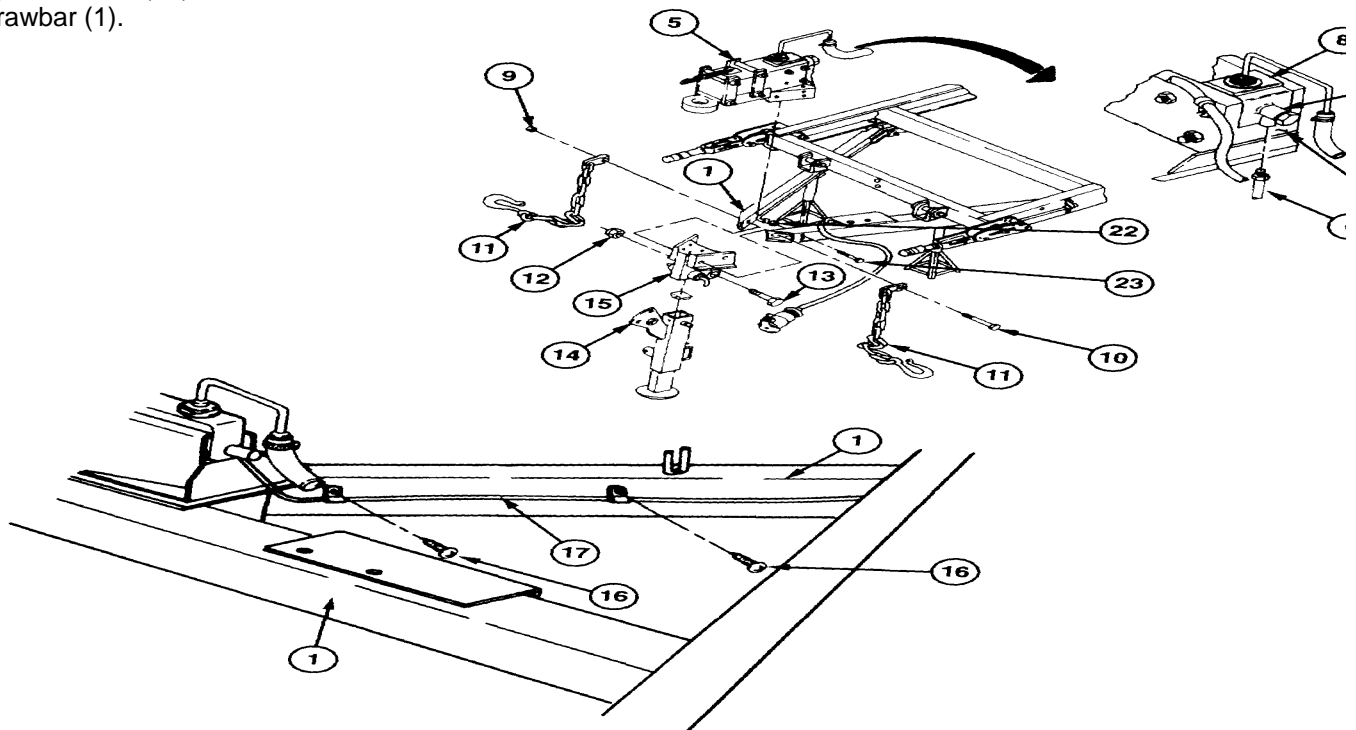
**4-38. HYDRAULIC BRAKE ACTUATOR ASSEMBLY REPLACEMENT (continued).**

3. Disconnect hydraulic brake front tube assembly (6) from connector (7) at master cylinder (8).
4. Remove self-locking nut (9), capscrew (10), and safety chain (11 ) from each of two drawbars (1). Discard self locking nuts.

**NOTE**

Bracket and adjustable front support leg is a one-piece welded assembly.

5. Remove self-locking nut (12), capscrew (13), and bracket with front support leg (14) from bracket and plunger assembly (15). Discard self-locking nut.
6. Remove two screws (16) and loosen hydraulic line (17) from curb-side drawbar (1).



**4-38. HYDRAULIC BRAKE ACTUATOR ASSEMBLY REPLACEMENT (continued).**

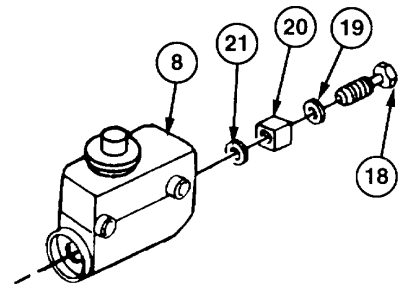
7. Remove fluid passage bolt (18), washer (19), connector (20), and washer (21) from master cylinder (8).

8. Remove four self-locking nuts (22) and capscrews (23) from hydraulic brake actuator assembly (5), bracket and plunger assembly (15), and two drawbars (1). Discard self-locking nuts.

9. Remove bracket and plunger assembly (15), with hydraulic brake actuator assembly (5), from two drawbars (1).

10. Remove two nuts (24), lockwashers (25), and capscrews (26) from bracket and plunger assembly (15) and hydraulic brake actuator assembly (5). Discard lockwashers.

11. Remove two capscrews (27) and lockwashers (28) from bracket and plunger assembly (15), and separate hydraulic brake actuator assembly (5) from bracket and plunger assembly (15). Discard lockwashers.



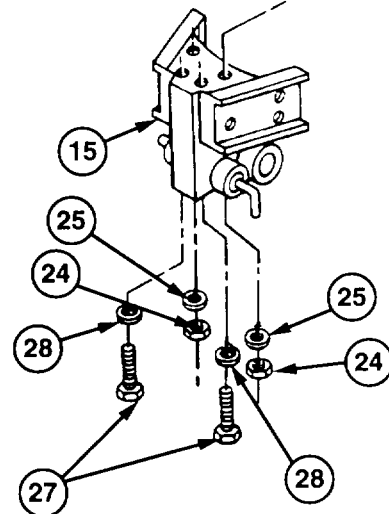
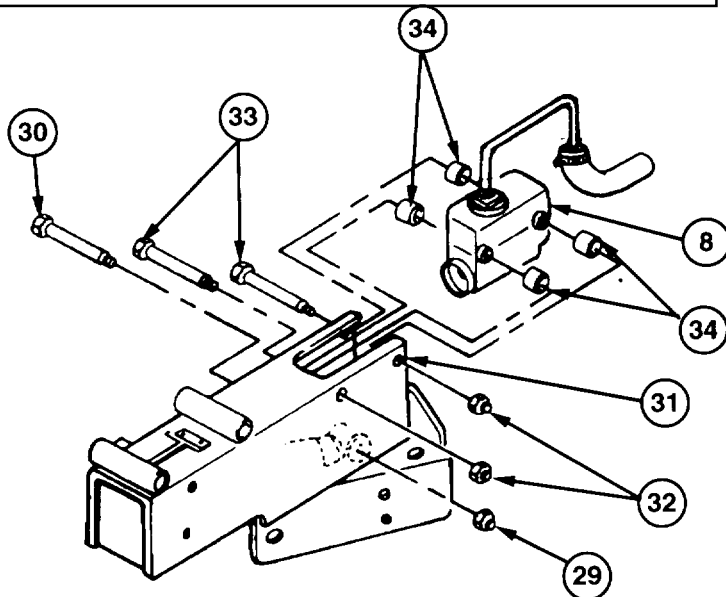
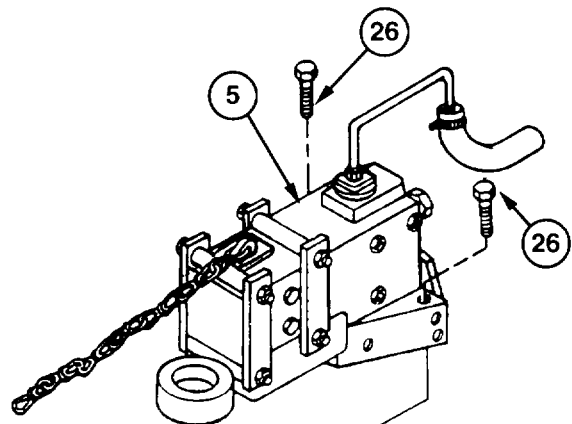
**b. DISASSEMBLY**

1. Remove self-locking nut (29) and capscrew (30) from channel (31). Discard self-locking nut.

**NOTE**

On newer-model trailers, spacers are welded to inside of channel.

2. Remove two self-locking nuts (32) and capscrews (33), four spacers (34), and master cylinder (8) from channel (31). Discard self-locking nuts.



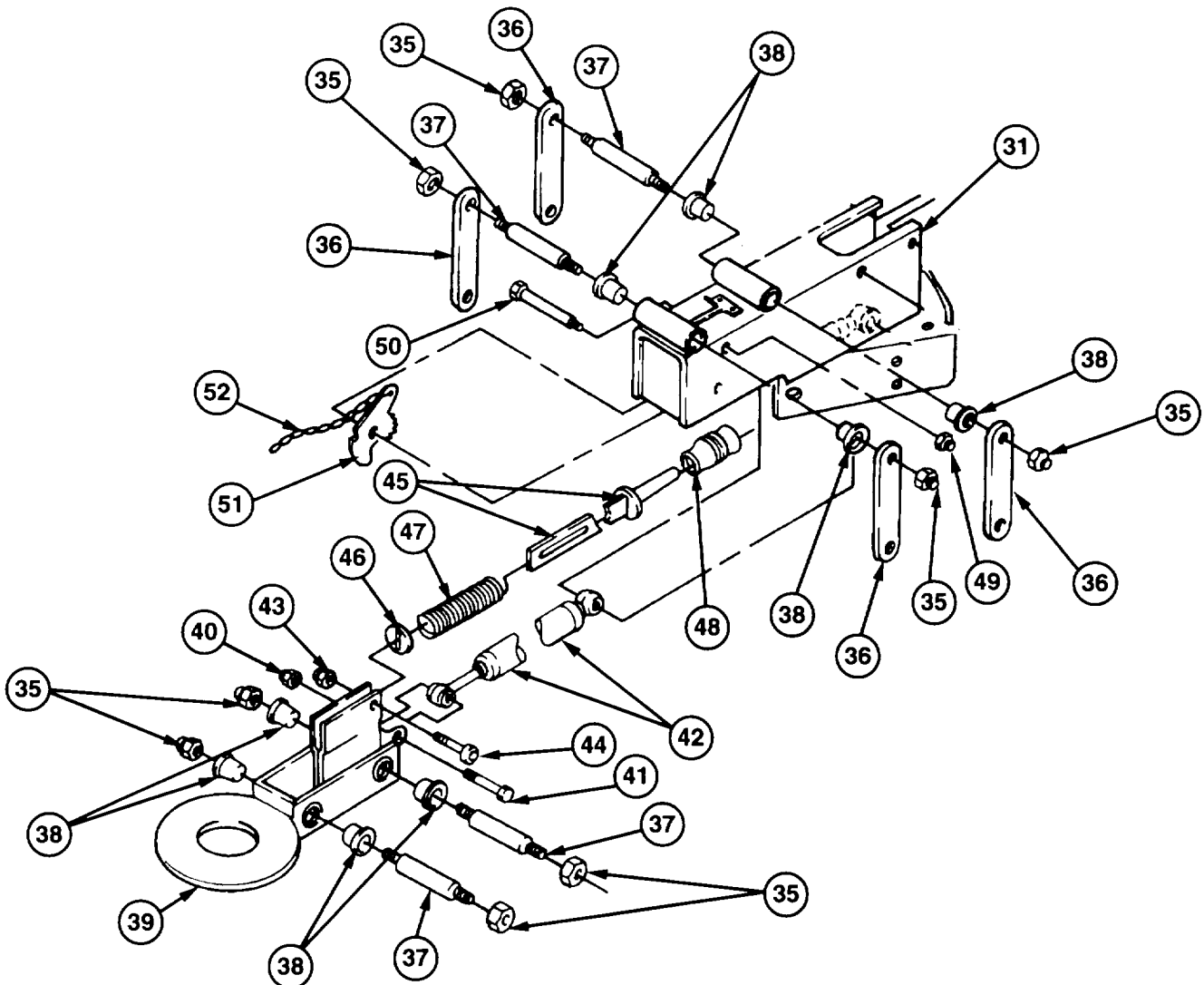
**4-38. HYDRAULIC BRAKE ACTUATOR ASSEMBLY REPLACEMENT (continued).**

3. Remove eight self-locking nuts (35), four links (36) and shafts (37), eight bearings (38), and drawbar coupler (39) from channel (31). Discard self-locking nuts.
4. Remove self-locking nut (40), capscrew (41), and shock absorber (42) from drawbar coupler(39). Discard self-locking nut.

**NOTE**

Boot may be in master cylinder.

5. Remove self-locking nut (43) and socket head screw (44) from drawbar coupler (39) and pushrod (45). Remove washer (46), spring (47), pushrod (45), and boot (48) from drawbar coupler (39). Discard self-locking nut.
6. Remove self-locking nut (49), capscrew (50), and breakaway lever (51), with chain (52) from channel (31). Discard self-locking nut.
7. If damaged, remove chain (52) from breakaway lever (51).

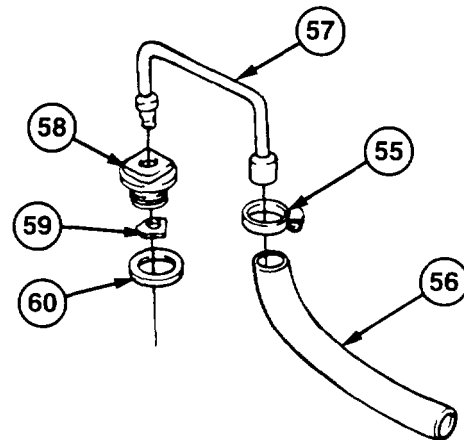
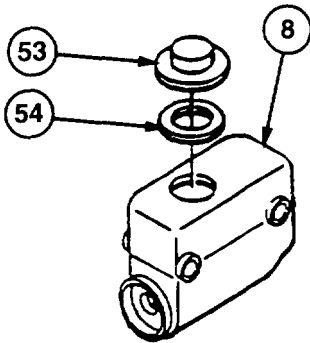




**4-38. HYDRAULIC BRAKE ACTUATOR ASSEMBLY REPLACEMENT (continued).****NOTE**

For trailers with master cylinder cap, do step 8. For trailers with drain hose, do steps 9 and 10.

8. Remove cap (53) and gasket (54) from master cylinder (8). Discard gasket if damaged.
9. Loosen clamp (55) and remove drain hose (56) from vent tube (57).
10. Remove vent tube (57), filler cap (58), baffle (59), and gasket (60) from master cylinder (8). Discard gasket if damaged.

**c. CLEANING AND INSPECTION****WARNING**

**Drycleaning solvent P-D-680 is toxic and flammable. Always wear protective goggles and gloves, and use only in a well-ventilated area. Avoid contact with skin, eyes, and clothes, and DO NOT breathe vapors. DO NOT use near open flame or excessive heat.**

1. Clean all removed components with drycleaning solvent and rag and allow to dry. Clean boot with detergent and water.
2. Inspect all removed components for wear, breaks, cracks, damaged welds, corrosion, or other damage. Replace if damaged.
3. Inspect breakaway lever for worn ratchet teeth. Replace if damaged.
4. Remove any corrosion with a wire brush.
5. Inspect for a worn slot in pushrod. Replace pushrod if slot is worn.
6. Inspect for a weak or broken spring. Replace if damaged.
7. Inspect shock absorber for leaks or bad rubber bushings. Replace if damaged.
8. Inspect master cylinder for leaks. Replace if damaged.

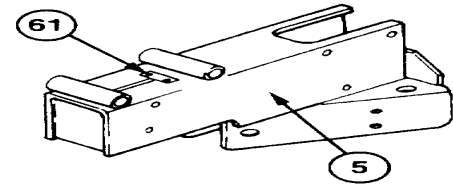
**4-38. HYDRAULIC BRAKE ACTUATOR ASSEMBLY REPLACEMENT (continued).**

9. Inspect channel for broken leaf spring (61). If leaf spring (61) is damaged, replace hydraulic brake actuator assembly (5).

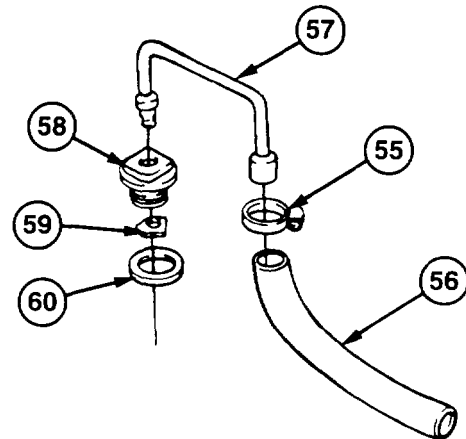
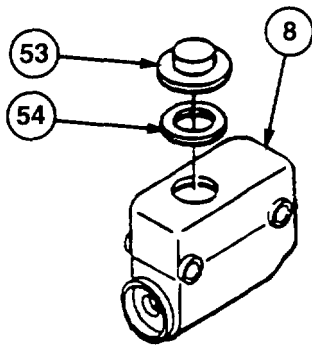
**d. ASSEMBLY**

**NOTE**

For trailers with master cylinder cap, do step 1.  
For trailers with drain hose, do steps 2 and 3.

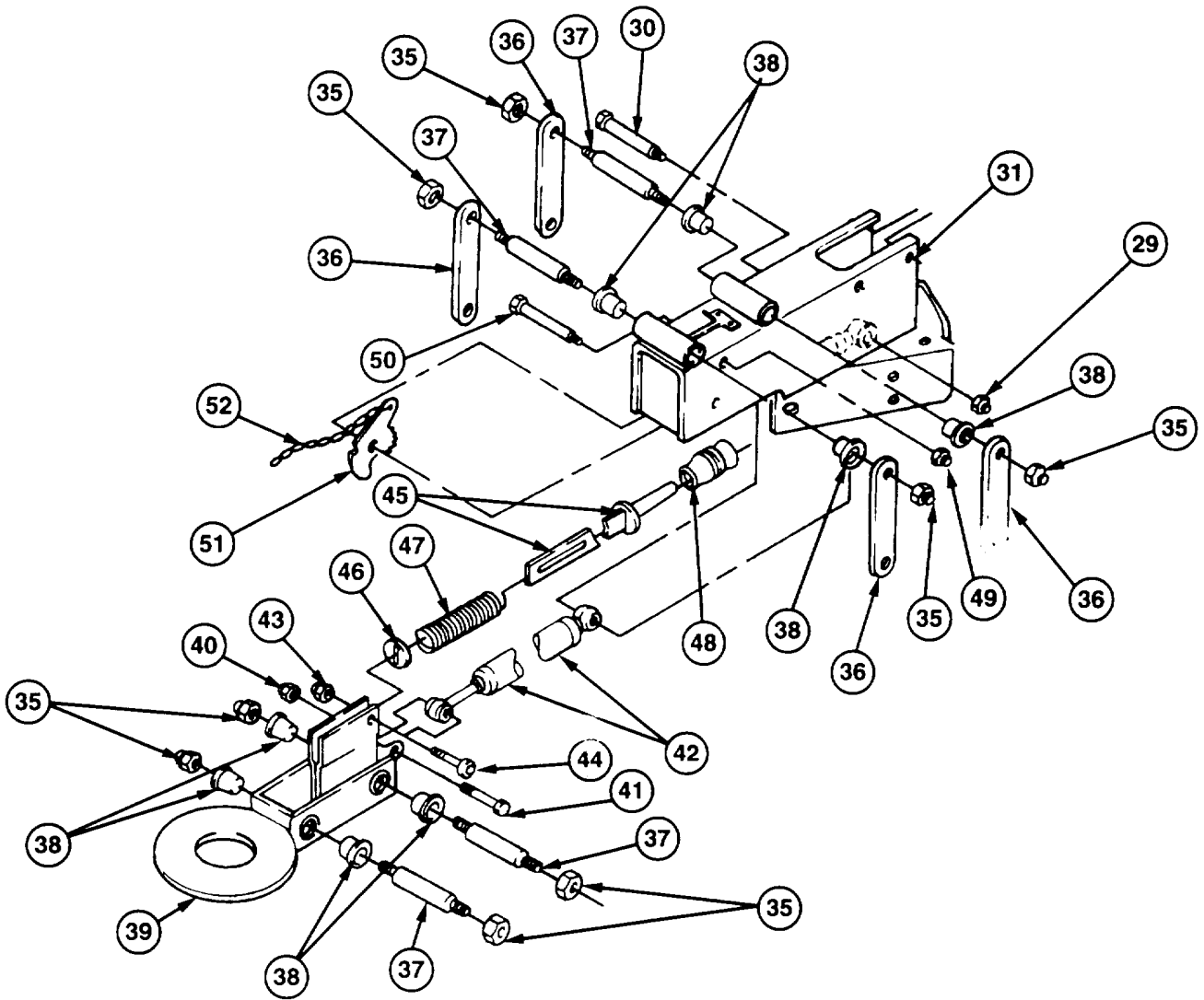


1. Install gasket (54) and cap (53) on master cylinder (8) and finger-tighten.
2. Install gasket (60), baffle (59), filler cap (58), and vent tube (57) on master cylinder (8).
3. Install drain hose (56) on vent tube (57) and tighten clamp (55).



4. If removed, install chain (52) on breakaway lever (51).
5. Position breakaway lever (51) in channel (31) with ratchet teeth facing leaf spring (61). Install capscrew (50) and new self-locking nut (49) on breakaway lever (51). Torque self-locking nut between 10 and 15 lb-ft (14-20 N•m)
6. If removed, attach boot (48) to rod end of pushrod (45). Assemble spring (47) and washer (46) on slot end of pushrod (45). Install slot end of pushrod (45) on drawbar coupler (39) with socket head screw (44) and new self-locking nut (43). Torque self-locking nut between 20 and 25 lb-ft (27-34 N•m).
7. Install piston rod end of shock absorber (42) on drawbar coupler (39) with capscrew (41) and new self-locking nut (40). Torque self-locking nut between 20 and 25 lb-ft (27-34 N•m).
8. Install drawbar coupler (39) on channel (31) with eight bearings (38), four shafts (37) and links (36), and eight new self-locking nuts (35). Torque self-locking nuts between 35 and 40 lb-ft (47-54 N•m).
9. Install other end of shock absorber (42) on channel (31) with capscrew (30) and new self-locking nut (29). Torque self-locking nut between 20 and 25 lb-ft (27-34 N•m).

4-38. HYDRAULIC BRAKE ACTUATOR ASSEMBLY REPLACEMENT (continued).

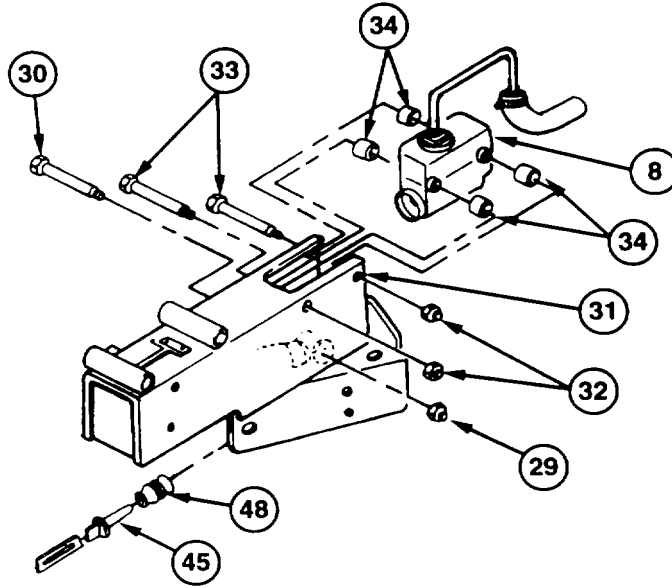


4-38. HYDRAULIC BRAKE ACTUATOR ASSEMBLY REPLACEMENT (continued).

**NOTE**

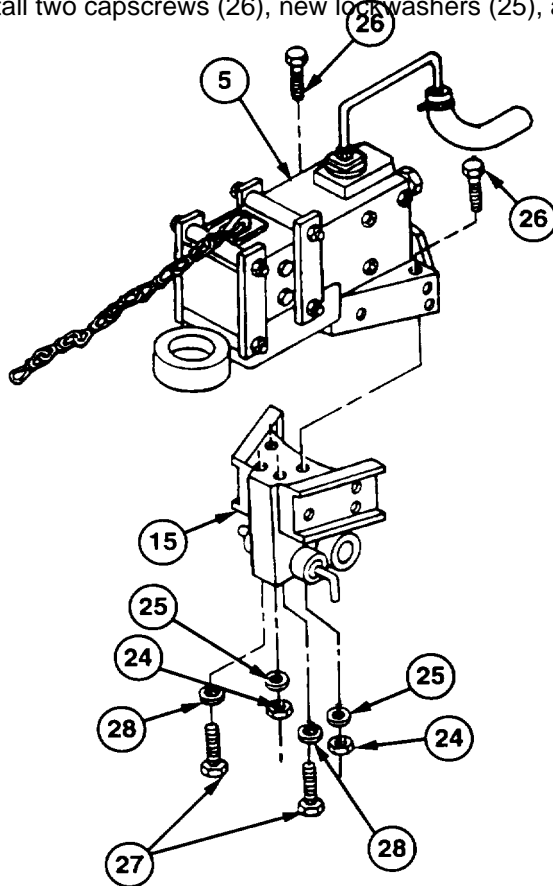
On newer-model trailers, spacers are welded to inside of channel.

10. Position master cylinder (8) and four spacers (34) in channel (31) with boot (48) engaged in pushrod (45). Install two capscrews (33) and new self-locking nuts (32) on master cylinder (8). Torque self-locking nuts between 10 and 15 lb-ft (14-20 N•m).



**e. INSTALLATION**

1. Install hydraulic brake actuator assembly (5) on bracket and plunger assembly (15) with two new lockwashers (28) and capscrews (27). Install two capscrews (26), new lock washers (25), and nuts (24) on bracket and plunger assembly (15).



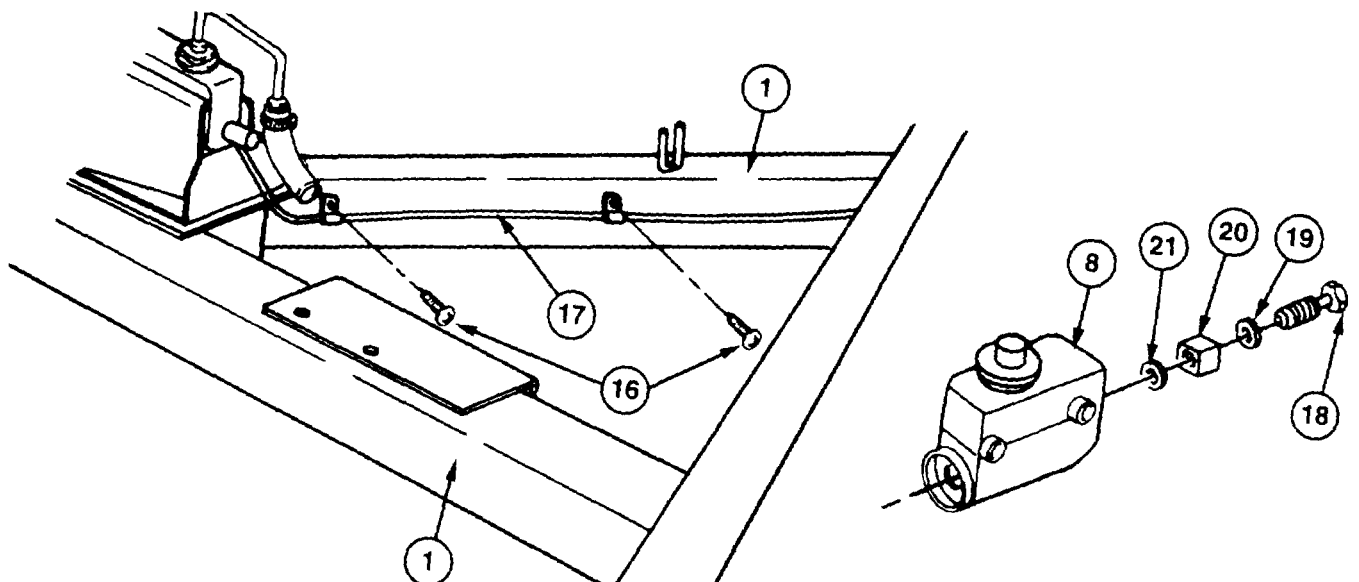
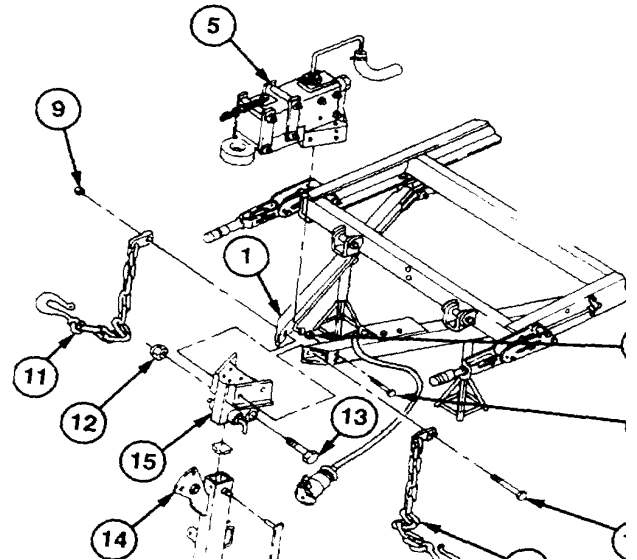
**4-38. HYDRAULIC BRAKE ACTUATOR ASSEMBLY REPLACEMENT (continued).**

2. Position hydraulic brake actuator assembly (5) with bracket and plunger assembly (15), at two drawbars (1).
3. Install four capscrews (23) and new self-locking nuts (22) on hydraulic brake actuator assembly (5), bracket and plunger assembly (15), and two drawbars (1). Torque self-locking nuts between 44 and 54 lb-ft (60-73 N.m).
4. Install washer (21), connector (20), washer (19), and fluid passage bolt (18) on master cylinder (8). Torque fluid passage bolt between 35 and 40 lb-ft (47-54 N-m).
5. Install hydraulic line (17) on curb-side drawbar (1) with two screws (16).

**NOTE**

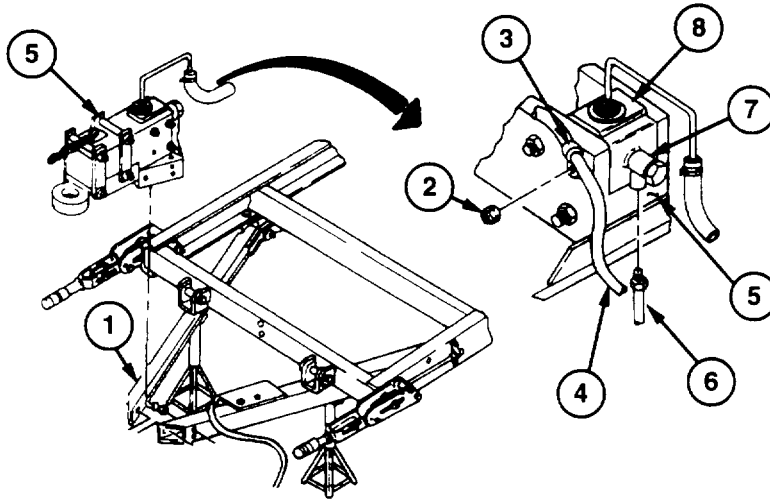
Bracket and adjustable front support leg is a one-piece welded assembly.

6. Install bracket with front support leg (14) on bracket and plunger assembly (15) with capscrew (13) and new self-locking nut (12).
7. Install two safety chains (11) on hydraulic brake actuator assembly (5), bracket and plunger assembly (15), and two drawbars (1) with two capscrews (10) and new self-locking nuts (9). Torque self-locking nut between 165 and 175 lb-ft (224-237 Nom).



**4-38. HYDRAULIC BRAKE ACTUATOR ASSEMBLY REPLACEMENT (continued).**

8. Connect hydraulic brake front tube assembly (6) to connector (7) at master cylinder (8).
9. Install loop clamp (3), with intervehicular cable (4) on hydraulic brake actuator assembly (5) with new self-locking nut (2).
10. Make sure front support leg (14) is locked in lowered position. Remove jackstands from under two drawbars (1).
11. If a new hydraulic brake actuator assembly (5) was installed, install new brake fluid caution decal to hydraulic brake actuator assembly (5) (para 1-13).

**FOLLOW-ON TASKS:**

- Lubricate hydraulic brake actuator assembly and service master cylinder as required (Appendix I).
- Bleed hydraulic brake system (para 4-41).

**4-39. MASTER CYLINDER REPLACEMENT.**

*This Task Covers:*

- a. Removal
- b. Cleaning and Inspection
- c. Installation

*Initial Setup:*

**Tools/Test Equipment:**

- General mechanic's tool kit (Item 1, Appendix B)
- Common No. 1 tool set (Item 2, Appendix B)
- Rag (Item 13, Appendix F)
- Solvent, drycleaning (Item 15, Appendix F)
- Self-locking nut (2), MS51922-21

**Materials/Parts:**

- Detergent (Item 5, Appendix F)

**a. REMOVAL**

**NOTE**

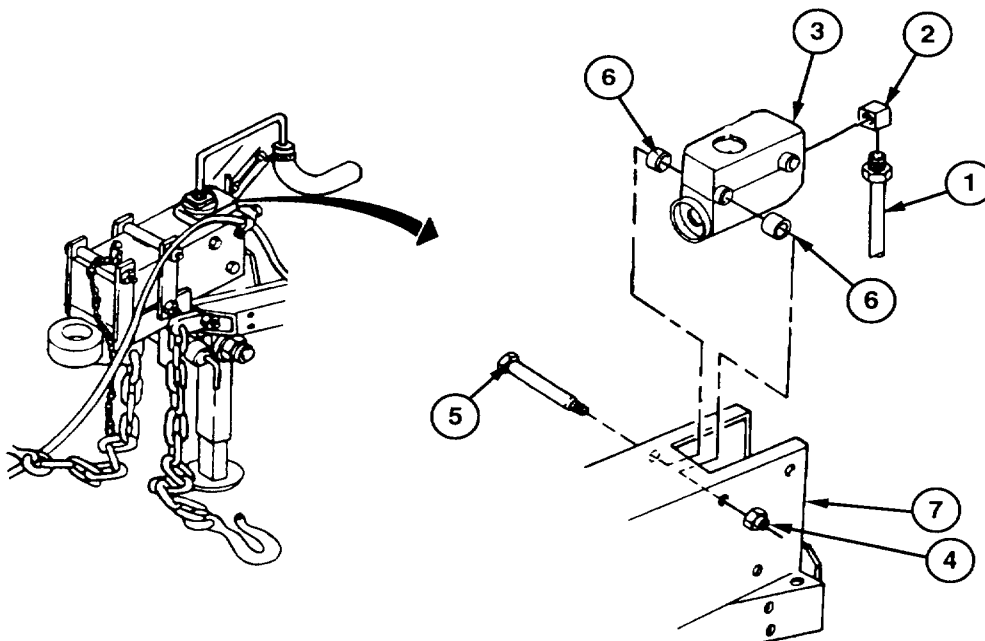
Use a suitable container to catch any draining brake fluid. Make sure all spills are cleaned up.

1. Disconnect hydraulic brake front tube assembly (1) from connector (2) at master cylinder (3).

**NOTE**

On newer-model trailers, spacers are welded to inside of channel.

2. Remove two self-locking nuts (4) and capscrews (5), four spacers (6), and master cylinder (3) from channel (7). Discard self-locking nuts.



**4-39. MASTER CYLINDER REPLACEMENT (continued).****NOTE**

The boot may be inside hydraulic brake actuator assembly.

3. Remove boot (8) from master cylinder (3) or from inside hydraulic brake actuator assembly (9).
4. Remove fluid passage bolt (10), washer (11), connector (2), and washer (12) from master cylinder (3).

**NOTE**

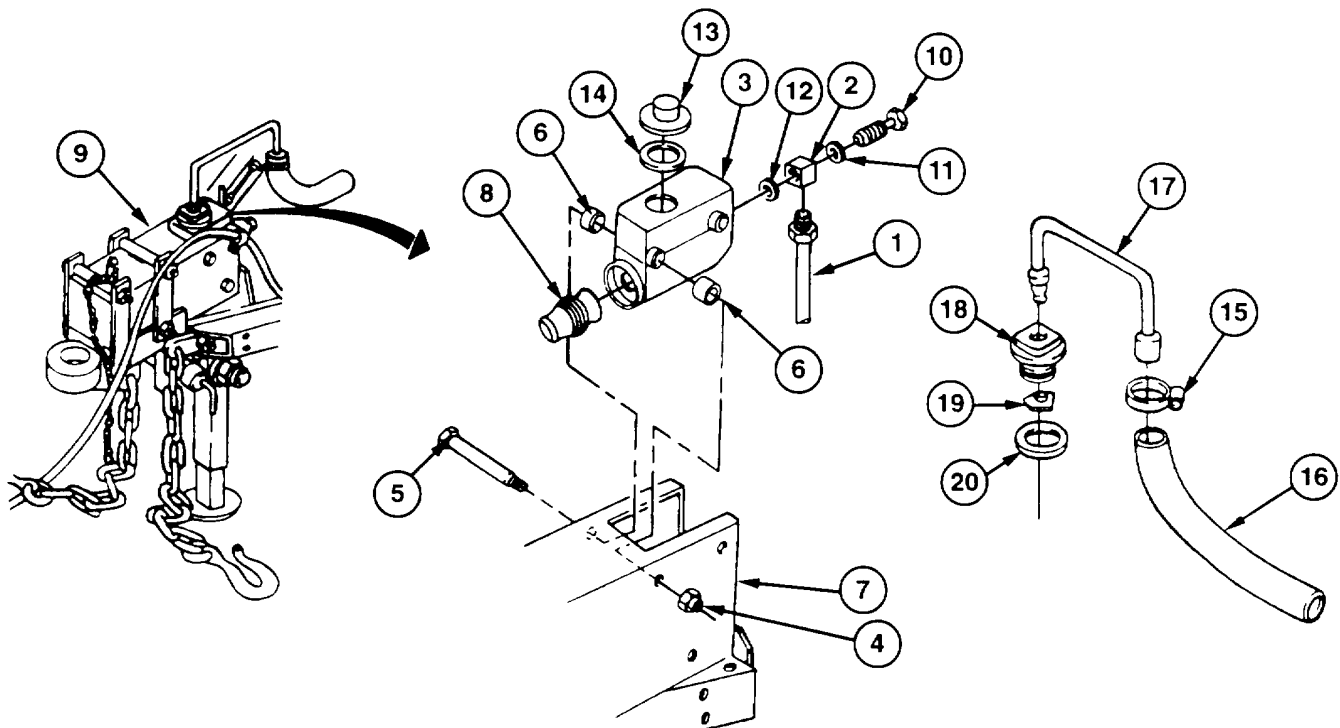
For trailers with master cylinder cap, do step 5. For trailers with drain hose, do step 6.

5. Remove cap (13) and gasket (14) from master cylinder (3). Discard gasket if damaged.
6. Loosen clamp (15) and remove drain hose (16) from vent tube (17).
7. Remove vent tube (17), filler cap (18), baffle (19), and gasket (20) from master cylinder (3). Discard gasket if damaged.

**b. CLEANING AND INSPECTION****WARNING**

**Drycleaning solvent P-D-680 is toxic and flammable. Always wear protective goggles and gloves, and use only in a well-ventilated area. Avoid contact with skin, eyes, and clothes, and DO NOT breathe vapors. DO NOT use near open flame or excessive heat.**

1. Clean all removed components except boot with drycleaning solvent and allow to dry. Clean boot with detergent and water.





---

**4-39. MASTER CYLINDER REPLACEMENT (continued).**

---

2. Inspect boot for tears. Replace if damaged.
3. Inspect master cylinder and mounting hardware for cracks, damaged threads, or other damage. Replace if damaged.

**c. INSTALLATION****NOTE**

For trailers with master cylinder cap, do steps 1 and 2. For trailers with drain hose, do steps 3 and 4.

1. Install gasket (14) and cap (13) on master cylinder (3).
2. Install fluid passage bolt (10), washer (11), connector (2), and washer (12) on master cylinder (3).
3. Install gasket (20), baffle (19), filler cap (18), and vent tube (17) on master cylinder (3).
4. Install drain hose (16) on vent tube (17) and tighten clamp (15).

**NOTE**

On newer-model trailers, spacers are welded to inside of channel.

5. Position boot (8), master cylinder (3), and four spacers (6) in channel (7) with boot (8) engaged inside hydraulic brake actuator assembly (9). Install two capscrews (5) and new self-locking nuts (4) on master cylinder (3). Torque self-locking nuts between 10 and 15 lb-ft (14-20 Nom).
6. Connect hydraulic brake front tube assembly (1) to connector (2) at master cylinder (3).

**FOLLOW-ON TASKS:**

- Service master cylinder (Appendix I).
- Bleed hydraulic brake system (para 4-41).

**4-40. HYDRAULIC BRAKE LINES REPLACEMENT.***This Task Covers:*

- |   |  |
|---|--|
| a. Front Tube Assembly Removal            | b. Front Tube Assembly Installation            |
| c. Rear Tube Assembly Removal             | d. Rear Tube Assembly Installation             |
| e. Hose Assembly Removal                  | f. Hose Assembly Installation                  |
| g. Left and Right Tube Assemblies Removal | h. Left and Right Tube Assemblies Installation |

*Initial Setup:***Tools/Test Equipment:**

- General mechanic's tool kit (Item 1, Appendix B)
- Common No. 1 tool set (Item 2, Appendix B)
- Lockwasher, MS35338-44
- Self-locking nut, MS51922-6 (M101A2, M101A3, M116A2, and M116A3)

**Materials/Parts:**

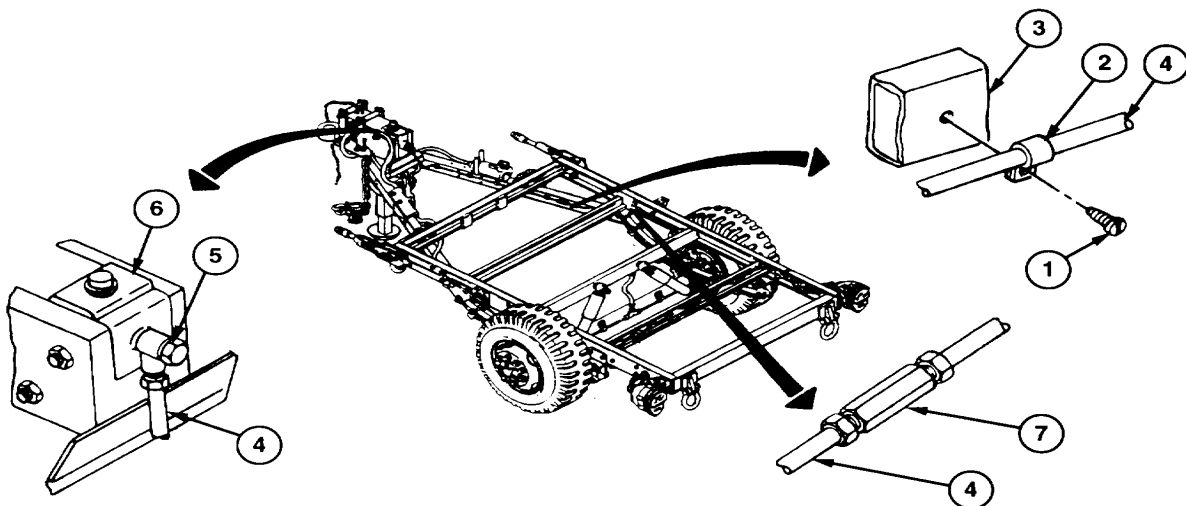
- Rag (Item 13, Appendix F)

**NOTE**

- Use a suitable container to catch any draining brake fluid. Make sure all spills are cleaned up.
- Quantity of mounting hardware varies slightly with model. Quantities indicated in task are for the M101A3 and the M116A3.
- For information on manufacturing tube assemblies, refer to Appendix G.

**a. FRONT TUBE ASSEMBLY REMOVAL**

1. Remove five screws (1) from five loop clamps (2) along curb-side drawbar (3).
2. Disconnect front tube assembly (4) from connector (5) at master cylinder (6).
3. Disconnect front tube assembly (4) from coupling (7). Remove front tube assembly from curb-side drawbar.
4. Remove five loop clamps (2) from front tube assembly (4).



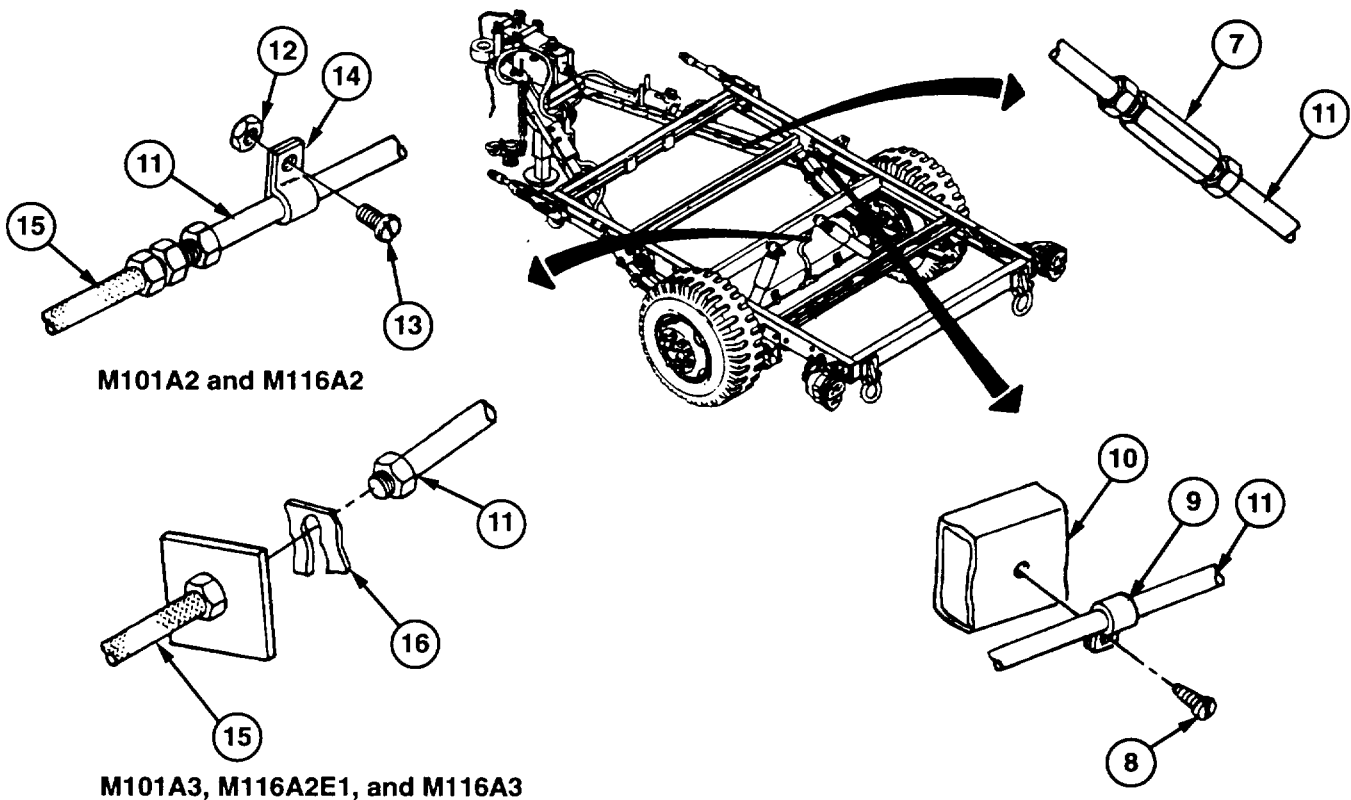
**4-40. HYDRAULIC BRAKE LINES REPLACEMENT (continued).**

**b. FRONT TUBE ASSEMBLY INSTALLATION**

1. Install five loop clamps (2) on front tube assembly (4).
2. Position front tube assembly (4) along curb-side drawbar (3) and connect to coupling (7).
3. Connect front tube assembly (4) to connector (5) at master cylinder (6).
4. Install five loop clamps (2) on curb-side drawbar (3) with five screws (1).

**c. REAR TUBE ASSEMBLY REMOVAL**

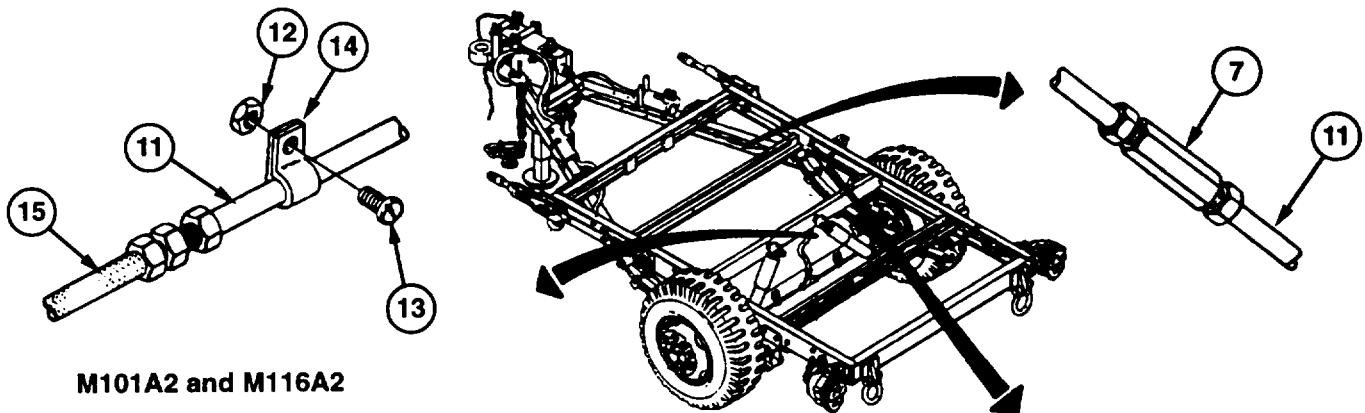
1. Remove two screws (8) from two loop clamps (9) along curb-side frame (10).
2. Disconnect rear tube assembly (11) from coupling (7).
3. On the M101A2 and M116A2, remove self-locking nut (12) and screw (13) from loop clamp (14) along crossmember. Disconnect rear tube assembly (11) from hose assembly (15) and remove. Discard self-locking nut.
4. On the M101A3, M116A2E1, and M116A3, remove rear tube assembly (11) from hose assembly (15) at retaining ring (16).
5. On the M101A2 and M116A2, remove two loop clamps (9) and loop clamp (14) from rear tube assembly (11).



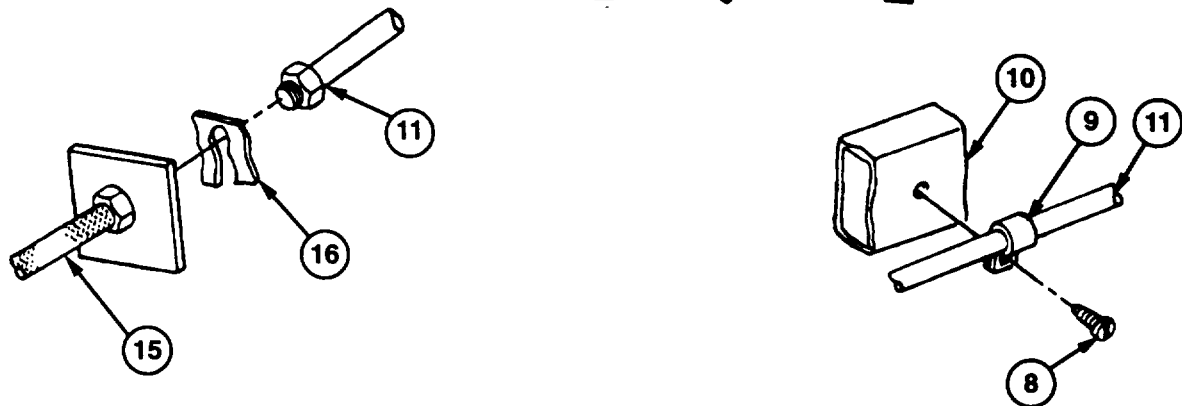
**4-40. HYDRAULIC BRAKE LINES REPLACEMENT (continued).**

**d. REAR TUBE ASSEMBLY INSTALLATION**

1. On the M101 A2 and M116A2, install two loop clamps (9) and loop clamp (14) on rear tube assembly (11).
2. Position rear tube assembly (11) along curb-side frame (10) and crossmember.
3. On the M101 A3, MI 16A2E1, and MI 16A3, connect rear tube assembly (11) to hose assembly (15) at retaining ring (16).
4. On the M101 A2 and MI 16A2, connect rear tube assembly (11) to hose assembly (15). Secure loop clamp (14) to crossmember with screw (13) and new self-locking nut (12).
5. Connect rear tube assembly (11) to coupling (7).
6. Install two loop clamps (9) on curb-side frame (10) with two screws (8).



**M101A2 and M116A2**



**M101A3, M116A2E1, and M116A3**

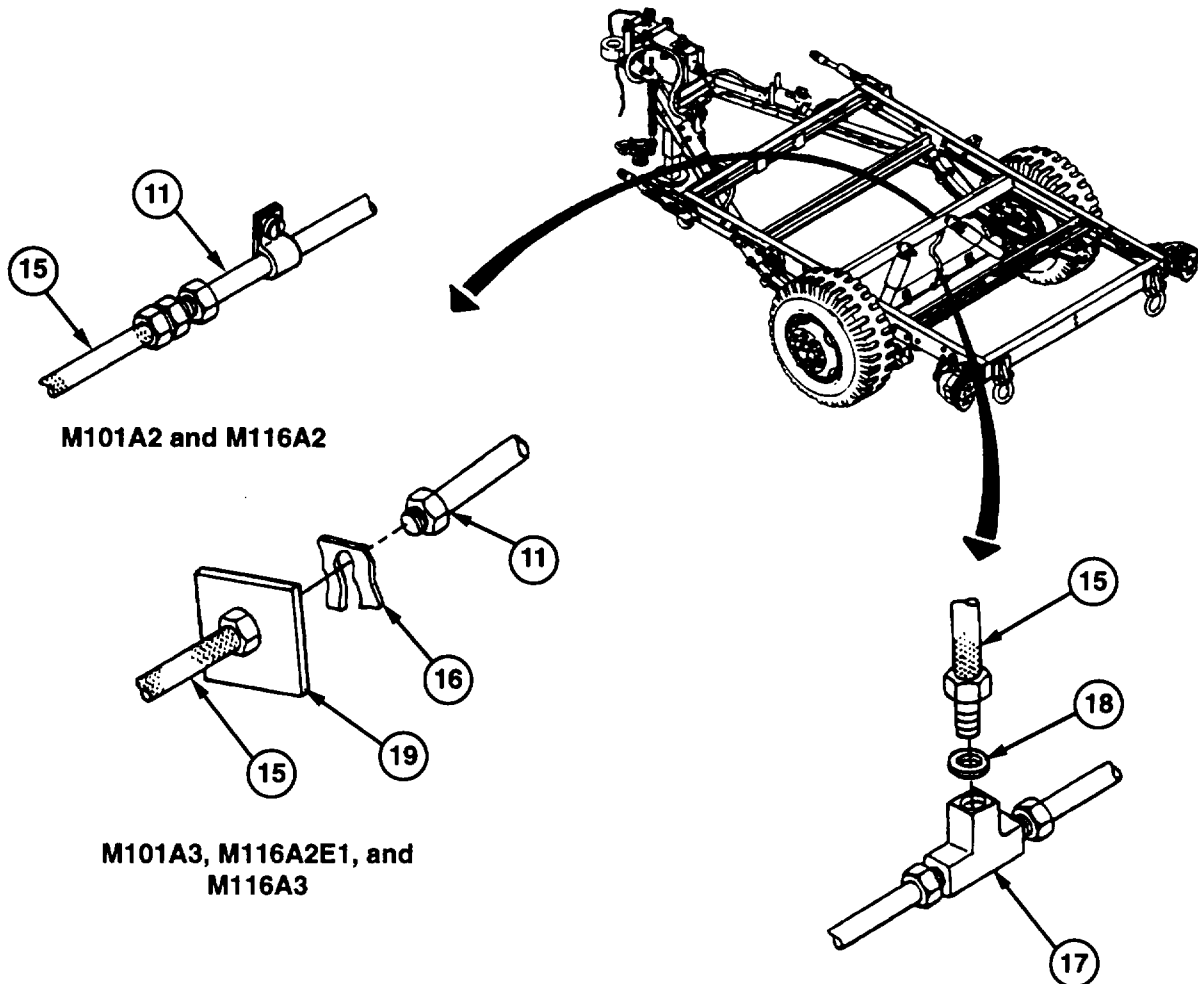
**4-40. HYDRAULIC BRAKE LINES REPLACEMENT (continued).**

**e. HOSE ASSEMBLY REMOVAL**

1. Disconnect hose assembly (15) from tee (17) at axle.
2. Remove copper gasket (18), if present, from hose assembly (15).
3. On the M101A3, M116A2E1, and M116A3, remove retaining ring (16) from hose assembly (15) and release hose assembly (15) from bracket (19) on crossmember.
4. Remove hose assembly (15) from rear tube assembly (11).

**f. HOSE ASSEMBLY INSTALLATION**

1. Connect hose assembly (15) to rear tube assembly (11).
2. On the M101A3, M116A2E1, and M116A3, secure hose assembly (15) to bracket (19) on crossmember with retaining ring (16).
3. Install copper gasket (18), if present, on hose assembly (15).
4. Connect hose assembly (15) to tee (17) at axle.



**4-40. HYDRAULIC BRAKE LINES REPLACEMENT (continued).****g. LEFT AND RIGHT TUBE ASSEMBLIES REMOVAL**

1. Disconnect tube assembly (20) from wheel cylinder (21).
2. Disconnect tube assembly (20) from tee (17) and remove from axle.

**NOTE**

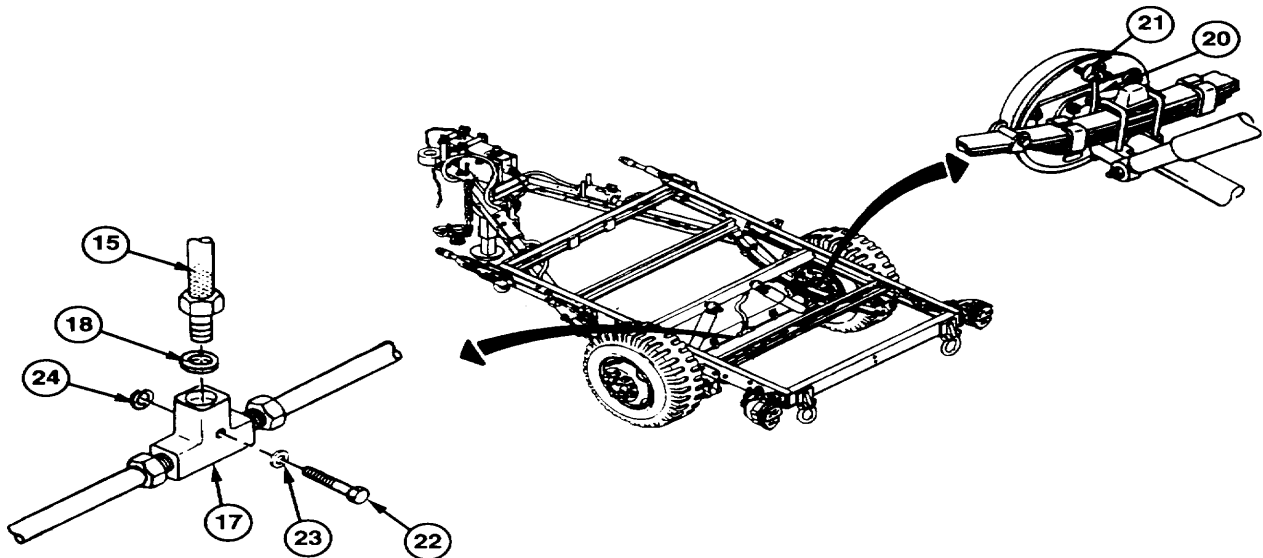
Do steps 3 and 4 to remove tee from axle.

3. Disconnect hose assembly (15) from tee (17). Remove copper gasket (18), if present, from hose assembly (15).
4. Remove capscrew (22), washer (23), tee (17), and lockwasher (24) from axle. Discard lockwasher.

**h. LEFT AND RIGHT TUBE ASSEMBLIES INSTALLATION****NOTE**

- Do steps 1 and 2 to install tee on axle.
- The procedure for installing assemblies is the same for left side and right side.

1. Install new lockwasher (24), tee (17), washer (23), and capscrew (22) on axle.
2. Install copper gasket (18), if present, on hose assembly (15). Connect hose assembly (15) to tee (17).
3. Position tube assembly (20) along axle and connect to tee (17).
4. Connect tube assembly (20) to wheel cylinder (21).

**FOLLOW-ON TASKS:**

- Bleed hydraulic brake system (para 4-41).

**4-41. BLEEDING HYDRAULIC BRAKE SYSTEM.***This Task Covers:*

Bleeding

*Initial Setup:***Tools/Test Equipment:**

- General mechanic's tool kit (Item 1, Appendix B)
- Rag (Item 13, Appendix F)
- Tubing, plastic (Item 20, Appendix F)

**Materials/Parts:**

- Fluid, brake (Item 6, Appendix F)
- Jar (Item 8, Appendix F)

**Equipment Conditions:**

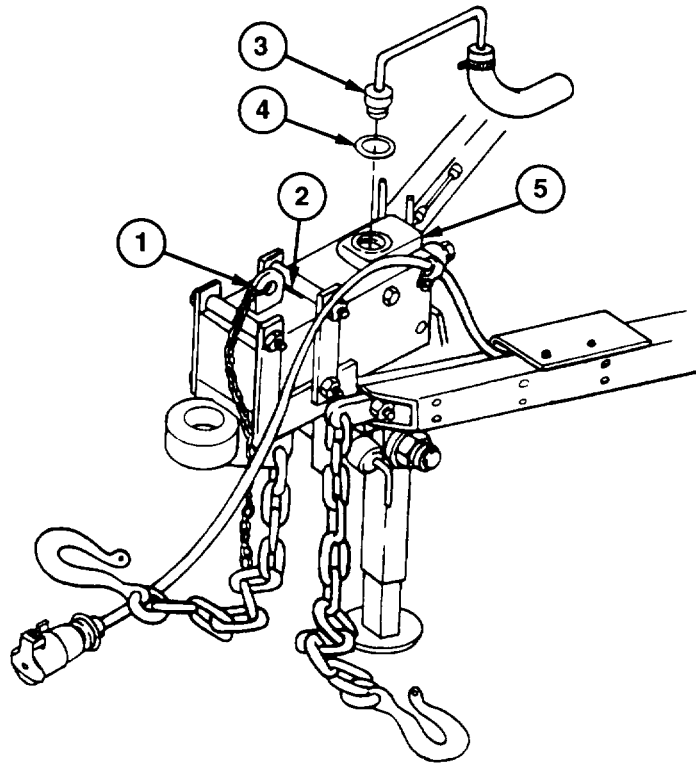
- Handbrakes applied (para 2-10).

**WARNING**

**When performing maintenance on brake system, make sure wheels are securely chocked. Failure to follow this warning may cause trailer to roll, resulting in serious injury or death to personnel or damage to equipment.**

**BLEEDING**

1. Release breakaway lever (1) by pulling up on leaf spring (2) and pushing down on breakaway lever (1). Release leaf spring (2).
2. Remove cap (3) and gasket (4) from master cylinder (5).
3. Fill master cylinder (5) with brake fluid to within 1/4 inch (6.35 mm) of top. Install gasket (4) and cap (3) on master cylinder (5) and finger-tighten.

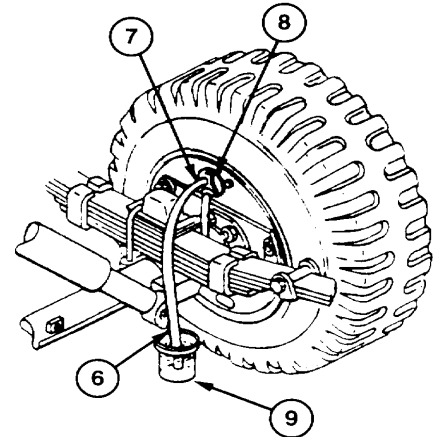


**4-41. BLEEDING HYDRAULIC BRAKE SYSTEM (continued).**

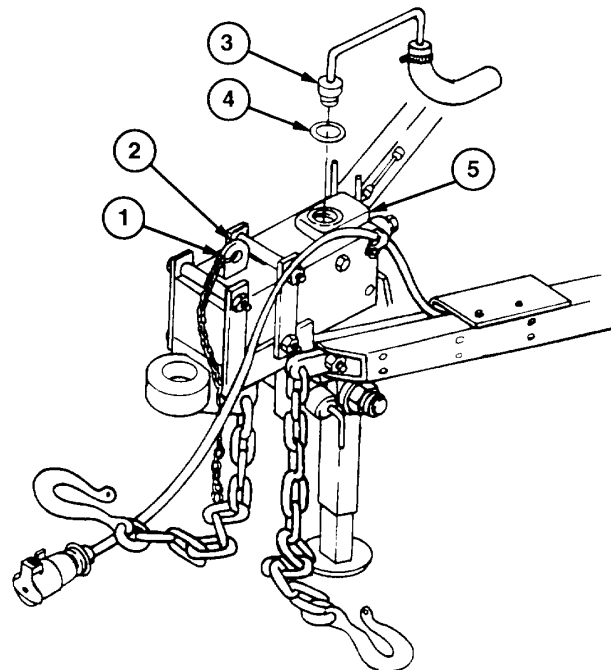
4. Install one end of hose (6) over bleeder valve (7) at wheel cylinder (8). Place free end of hose (6) in clean jar (9).
5. Fill jar (9) half full with brake fluid. Make sure free end of hose (6) is below the level of brake fluid.

**NOTE**

Make sure master cylinder is kept full of brake fluid at all times during bleeding or air will enter the system, making it necessary to bleed the system again.



6. Apply and release breakaway lever (1) four to five times, to apply pressure to brake system.
7. Leave breakaway lever (1) in applied position.
8. Open bleeder valve (7) to release air from brake system. Air is being released if there are air bubbles in jar (9).
9. Close bleeder valve (7). Remove hose (6) from bleeder valve (7)
10. Repeat steps 6 through 9 until fluid in jar (9) is free of air bubbles.
11. Release breakaway lever (1).
12. Remove cap (3) and gasket (4) from master cylinder (5). Discard gasket if damaged.
13. Fill master cylinder (5) with brake fluid.
14. Install gasket (4) and cap (3) on master cylinder (5).



**FOLLOW-ON TASKS:**

- None



**Section VIII. WHEELS, HUBS, AND BRAKEDRUMS MAINTENANCE**

Paragraph Number	Paragraph Title	Page Number
4-42	General .....	4-83
4-43	Hub, Brakedrum, and Wheel Bearings Maintenance .....	4-83
4-44	Wheel and Tire Assembly Replacement .....	4-90
4-45	Tire and Tube Maintenance .....	4-91

**4-42. GENERAL.**

This section describes and illustrates maintenance procedures for hubs, brakedrums, wheel bearings, wheel and tire assembly, tires, and tubes.

**4-43. HUB, BRAKEDRUM, AND WHEEL BEARINGS MAINTENANCE.**

*This Task Covers:*

- |                            |                             |
|----------------------------|-----------------------------|
| a. Removal                 | b. Disassembly              |
| c. Cleaning and Inspection | d. Assembly                 |
| e. Installation            | f. Wheel Bearing Adjustment |

*Initial Setup:*

**Tools/Test Equipment:**

- General mechanic's tool kit (Item 1, Appendix B)
- Common No. 1 tool set (Item 2, Appendix B)
- Cotter pin, MS24665-425
- Seal, 12313027

**Materials/Parts:**

- Cloth, abrasive (Item 3, Appendix F)
- Grease (Item 7, Appendix F)
- Rag (Item 13, Appendix F)
- Solvent, drycleaning (Item 15, Appendix F)

**Equipment Conditions:**

- Wheel and tire assembly removed (para 4-44).
- Handbrakes released (para 2-10).

**References:**

- TM 9-214

**WARNING**

**DO NOT handle brakeshoes, brakedrums, or other brake components unless area has been properly cleaned. Asbestos dust, which can be dangerous if you touch it or breathe it, may be on these components. Failure to follow this warning may result in serious illness or death to personnel.**

**a. REMOVAL**

1. Support vehicle with suitable jackstands at front and rear corners on side being maintained.

**4-43. HUB, BRAKEDRUM, AND WHEEL BEARINGS MAINTENANCE (continued).**

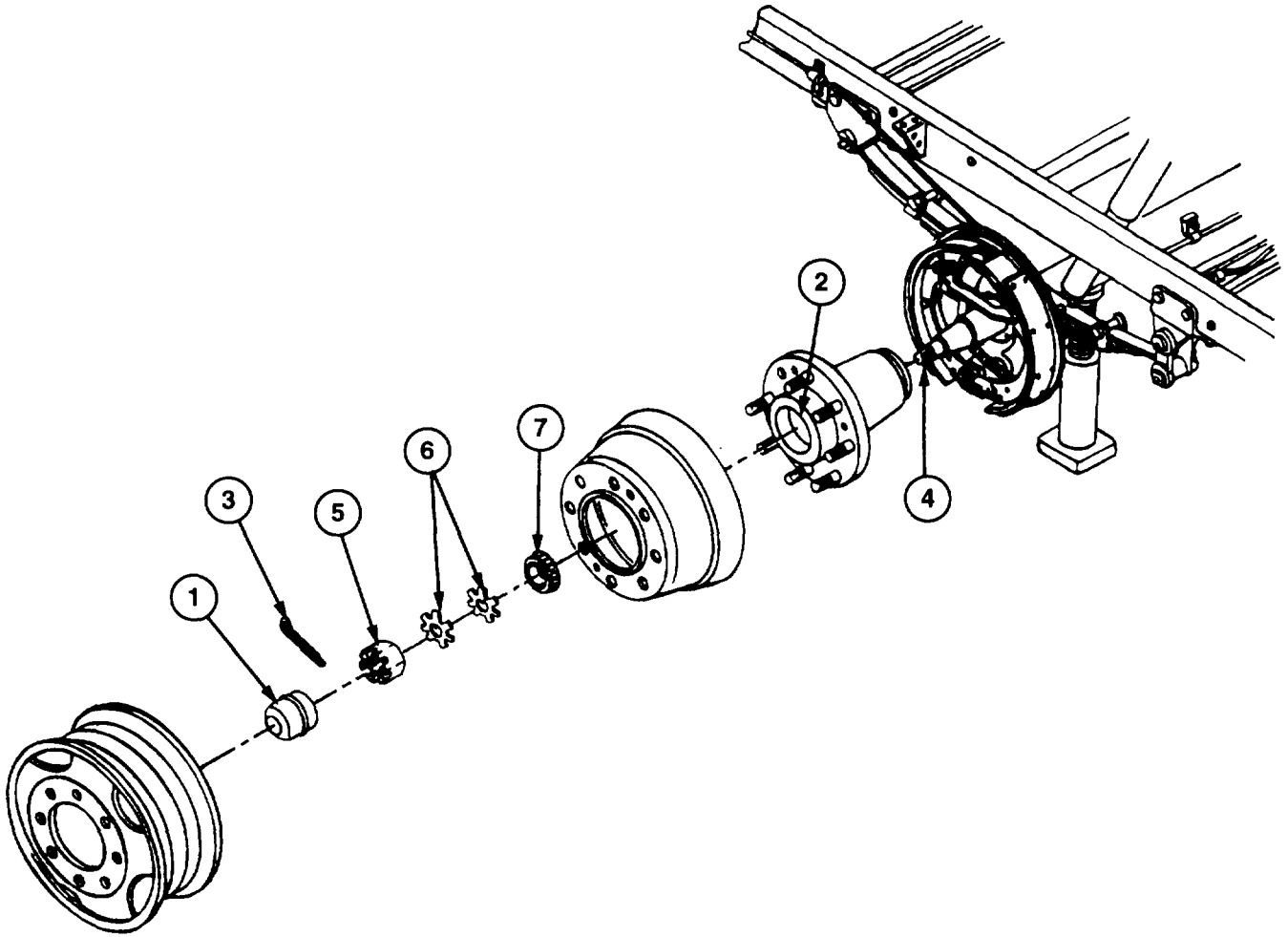
2. Remove grease cap (1) from hub (2).

3. Remove cotter pin (3) from spindle (4). Discard cotter pin.

**NOTE**

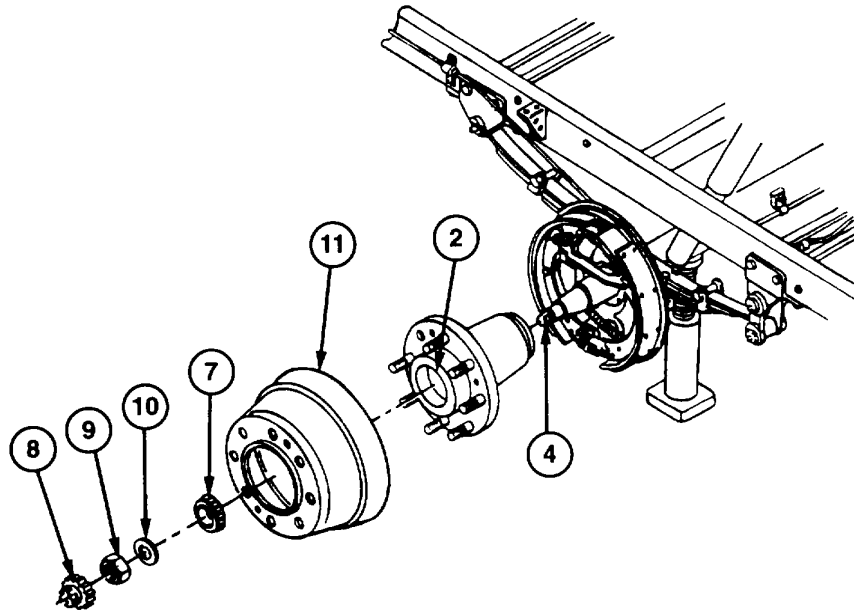
Configurations may vary. If trailer has key washers, do step 4. If trailer is equipped with retainers and washers, do step 5.

4. Remove nut (5), two key washers (6), and outer bearing (7) from spindle (4).



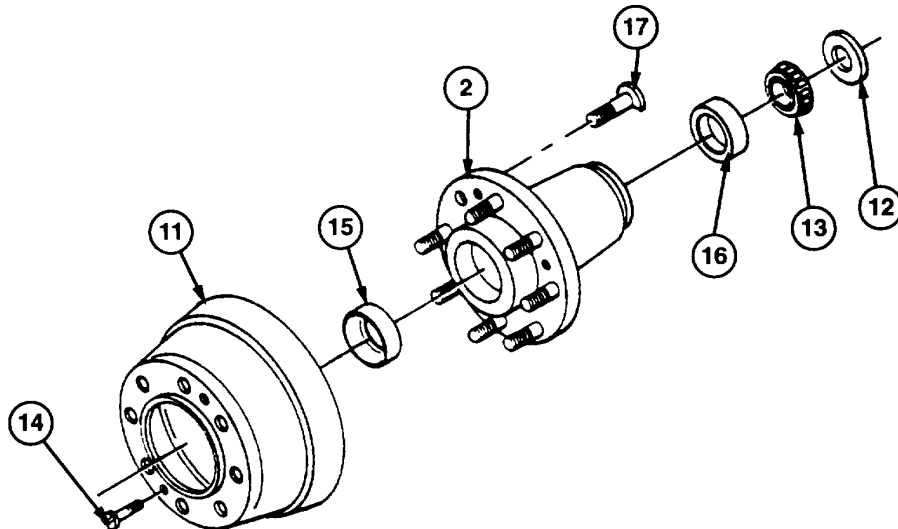
**4-43. HUB, BRAKEDRUM, AND WHEEL BEARINGS MAINTENANCE (continued).**

5. Remove retainer (8), nut (9), washer (10), and outer bearing (7) from spindle (4).
6. Remove hub (2) and brakedrum (11), as an assembly, from spindle (4).



**b. DISASSEMBLY**

1. Remove seal (12) and inner bearing (13) from hub (2). Discard seal.
2. Remove two machine screws (14) from hub (2) and brakedrum (11). Separate hub (2) and brakedrum (11).
3. Remove outer and inner cups (15 and 16) from hub (2).
4. If damaged, drive out eight shoulder bolts (17) from hub (2) and discard.



---

**4-43.HUB, BRAKEDRUM, AND WHEEL BEARINGS MAINTENANCE (continued).**


---

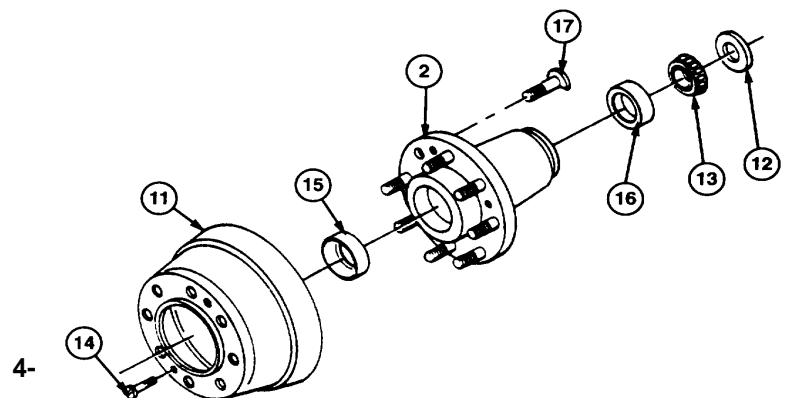
**c.CLEANING AND INSPECTION****WARNING**

- **Wear an approved filter mask and gloves. NEVER use compressed air or a dry brush to clean brake components. Dust may be removed using an industrial-type vacuum cleaner. Clean dust or mud away from brake components with water and a wet, soft brush or cloth.**
- **Drycleaning solvent P-D-680 is toxic and flammable. Always wear protective goggles and gloves, and use only in a well-ventilated area. Avoid contact with skin, eyes, and clothes, and DO NOT breathe vapors. DO NOT use near open flame or excessive heat.**

1. Clean and inspect inner and outer bearings and cups in accordance with TM 9-214. If any bearing or cup needs replacing, all bearings and cups must be replaced.
2. Clean all other removed components with drycleaning solvent and rag and allow to dry.
3. Wipe spindle clean with drycleaning solvent and rag. Inspect spindle for cracks, bends, and scored or discolored bearing surfaces. If threads are damaged, restore. Notify Direct Support maintenance if spindle is damaged beyond repair.
4. Inspect hub for cracks, breaks, and burrs. Remove burrs with abrasive cloth. Replace hub if damaged.
5. Inspect brakedrum for cracks, scoring, pitting, and grooves. Notify Direct Support maintenance if brakedrum is damaged.
6. Inspect all remaining components for damage. Replace if damaged.

**d.ASSEMBLY**

1. If removed, drive eight new shoulder bolts (17) into hub (2).
2. Install outer and inner cups (15 and 16) in hub (2).
3. Align holes in brakedrum (11) with holes in hub (2). Loosely install two machine screws (14) in brakedrum (11).
4. Tap brakedrum (11) against hub (2) with soft-faced hammer. Fully tighten two machine screws (14).
5. Pack inner bearing (13) with grease and install in hub (2).
6. Install new seal (12) in hub (2).



---

**4-43. UB, BRAKEDRUM, AND WHEEL BEARINGS MAINTENANCE (continued).**

---

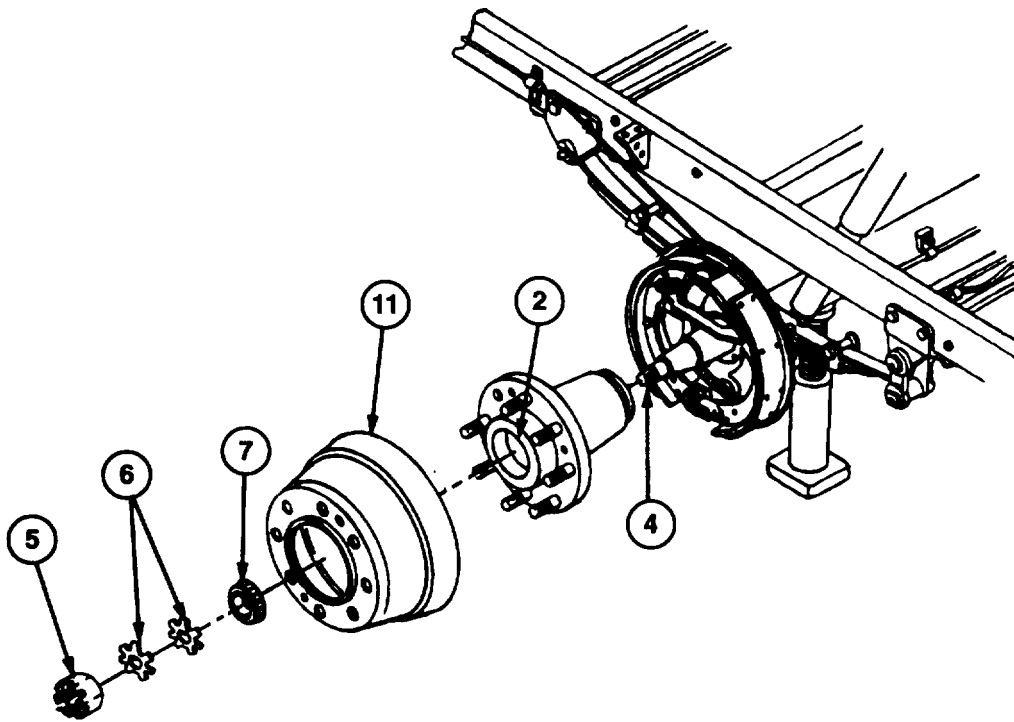
**e.INSTALLATION**

1. Lightly coat spindle (4) with grease.
2. Install hub (2) and brakedrum (11), as an assembly, on spindle (4).
3. Pack outer bearing (7) with grease and install on spindle (4).

**NOTE**

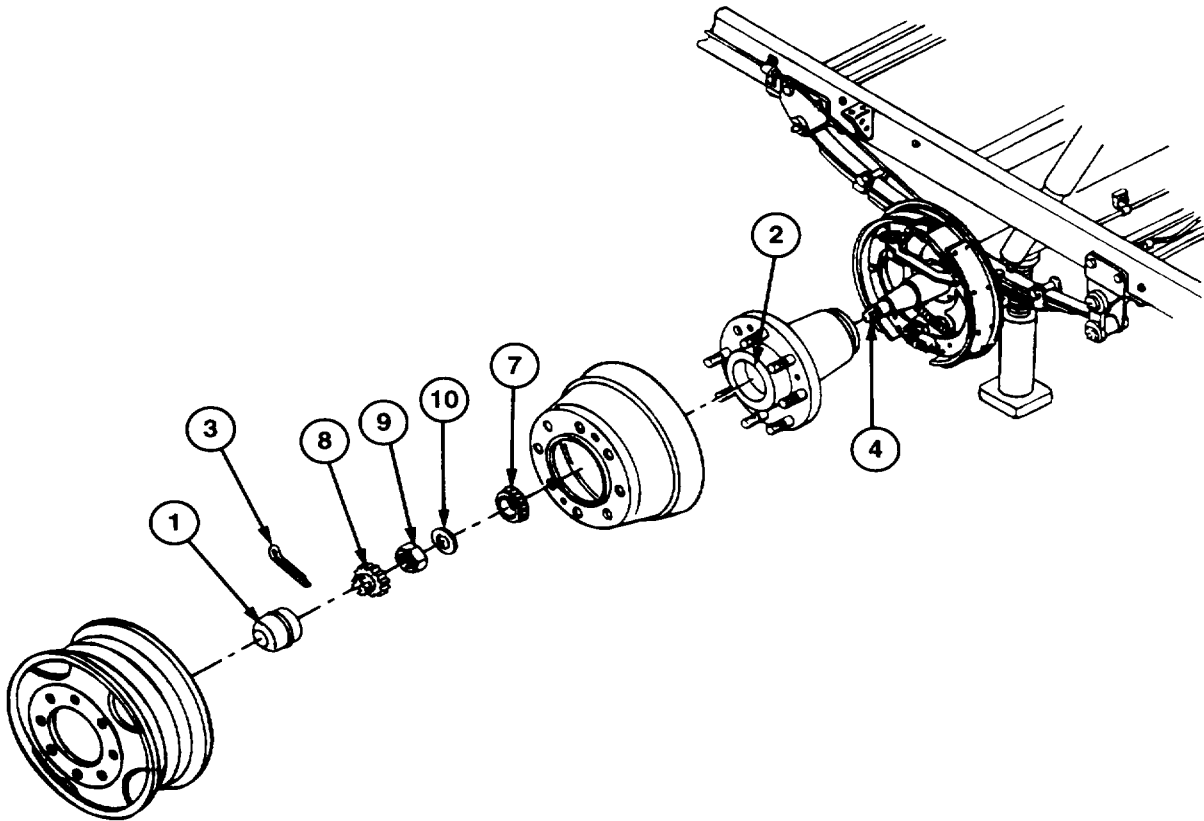
Configurations may vary. If trailer has key washers, do step 4. If trailer is equipped with retainers and washers, do step 5.

4. Install two key washers (6) and nut (5) on spindle (4).



**4-43. HUB, BRAKEDRUM, AND WHEEL BEARINGS MAINTENANCE (continued).**

5. Install washer (10), nut (9), and retainer (8) on spindle (4).
6. Perform wheel bearing adjustment (subpara f).

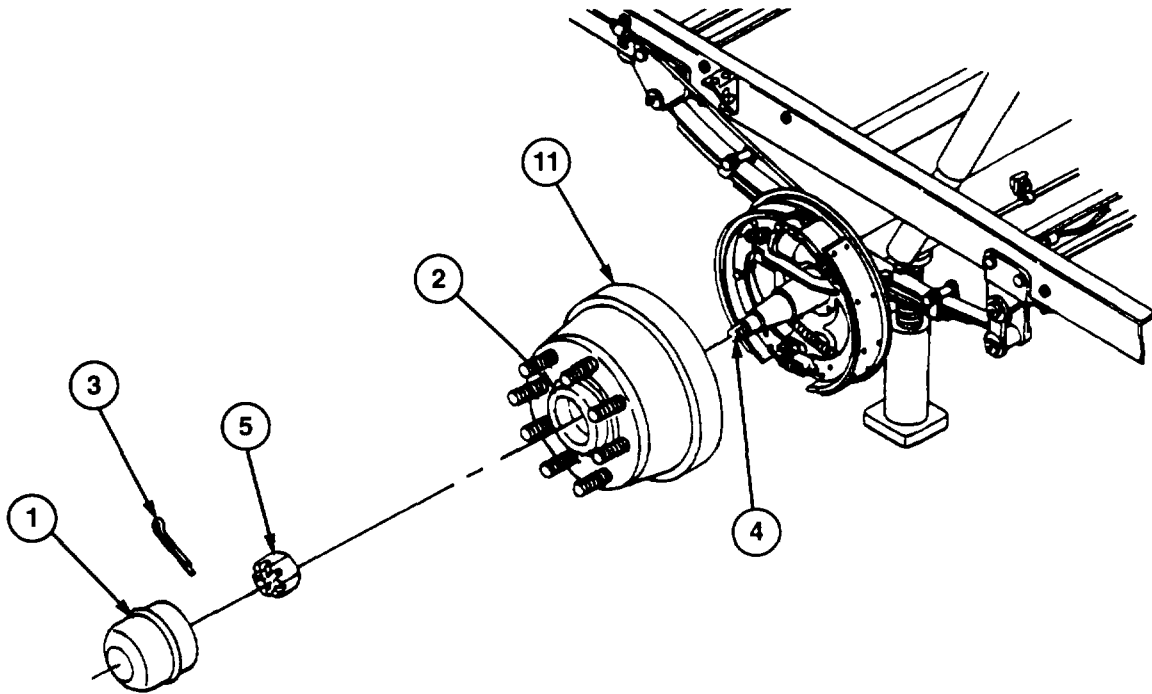
**f. WHEEL BEARING ADJUSTMENT****NOTE**

- If performing wheel bearing adjustment as part of troubleshooting when wheel and tire assembly has not been removed, perform steps 1 through 12.
- If performing wheel bearing adjustment as a follow-on to hub, brakedrum, and wheel bearings maintenance, perform steps 5 through 12 only.

1. Apply handbrakes (para 2-10). Chock wheel and tire assembly opposite the side being adjusted. Raise vehicle at front and rear corners of side being maintained until wheel and tire assembly is clear of ground. Support vehicle with suitable jackstand.
2. Release handbrake on side being adjusted (para 2-10).
3. Remove grease cap (1) from hub (2).
4. Remove cotter pin (3) from spindle (4). Discard cotter pin.

**4-43. HUB, BRAKEDRUM, AND WHEEL BEARINGS MAINTENANCE (continued).**

5. Loosen nut (5) on spindle (4) until hub (2) and brakedrum (11) turn freely.
6. Torque nut (5) to 30 lb-ft (41 Nom) while turning hub (2) and brakedrum (11), to seat bearings.
7. Back off nut (5) 1/16 turn. Finger-tighten nut.
8. Install new cotter pin (3) in spindle (4) and bend back ends. Make sure hub (2) and brakedrum (11) turn freely.
9. Install grease cup (1) on hub (2).
10. Apply handbrakes (para 2-10).
11. If removed, install wheel and tire assembly (para 4-44).
12. Remove jackstands and lower vehicle.

**FOLLOW-ON TASKS:**

- None

**4-44. WHEEL AND TIRE ASSEMBLY REPLACEMENT.***This Task Covers:*

- a. Removal b. Installation

*Initial Setup:***Tools/Test Equipment: Equipment Conditions:**

- General mechanic's tool kit (Item 1, Appendix B)
- Handbrakes applied (para 2-10).
- Common No. 1 tool set (Item 2, Appendix B)

**NOTE**

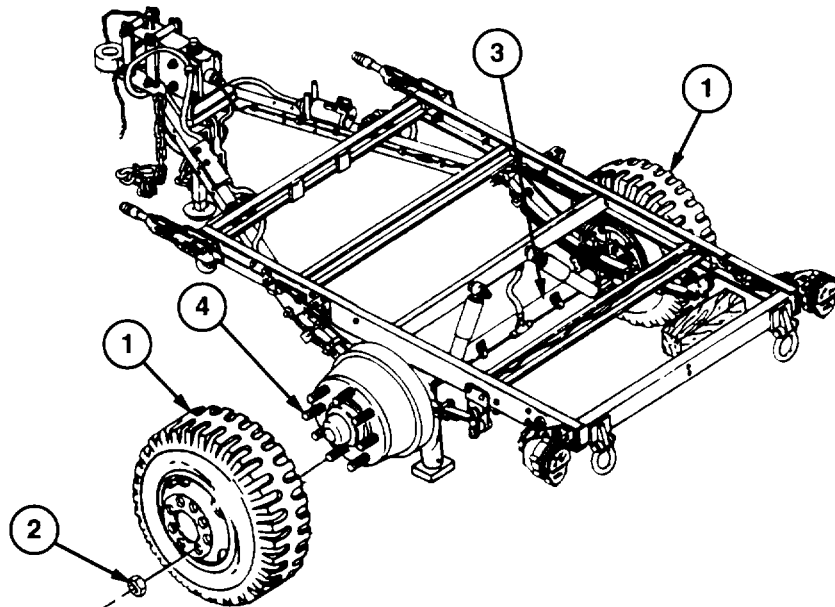
This procedure shows replacement of the M116A2 or M116A2E1 wheel and tire assembly.

**a.REMOVAL**

1. Chock wheel and tire assembly (1) opposite side being removed.
2. Loosen eight nuts (2) on wheel and tire assembly (1).
3. Raise and support axle (3) on side where wheel and tire assembly (1) is being removed.
4. Remove eight nuts (2) from wheel and tire assembly (1). Remove wheel and tire assembly (1) from shoulder bolts (4).

**b.INSTALLATION**

1. Install wheel and tire assembly (1) on shoulder bolts (4).
2. Install eight nuts (2) on wheel and tire assembly (1) and tighten alternately and evenly.
3. Remove support from axle (3) and lower wheel and tire assembly (1) to the ground.
4. Torque eight nuts (2) alternately and evenly between 110 and 120 lb-ft (149-163 N•m).

**FOLLOW ON TASKS:**

- None



---

**4-45. TIRE AND TUBE MAINTENANCE.**

---

To remove tire from wheel, to repair tube (if present), or to repair wheel and run flat assembly (M101 A3 and MI 16A3), refer to TM 9-2610-200-14.

**Section IX. FRAME AND TOWING ATTACHMENTS MAINTENANCE**

Paragraph Number	Paragraph Title	Page Number
4-46	General .....	4-92
4-47	Spring Hanger Replacement.....	4-92
4-48	Lift Shackle Replacement .....	4-97
4-49	Eyebolt Replacement.....	4-98
4-50	Drawbar Replacement .....	4-99
4-51	Adjustable Front Support Leg Replacement.....	4-101
4-52	Safety Chains Replacement .....	4-103

**4-46. GENERAL.**

This section describes and illustrates removal and installation procedures for spring hangers, lift shackles, eyebolts, drawbars, the adjustable front support leg, and safety chains.

**4-47. SPRING HANGER REPLACEMENT.**

*This Task Covers:*

- |                                     |                                    |
|-------------------------------------|------------------------------------|
| a. Front Spring Hanger Removal      | b. Rear Spring Hanger Removal      |
| c. Cleaning and Inspection          | d. Rear Spring Hanger Installation |
| e. Front Spring Hanger Installation |                                    |

*Initial Setup:*

**Tools/Test Equipment:**

- |  |   |
|--|---|
| <ul style="list-style-type: none"> <li>• General mechanic's tool kit (Item 1, Appendix B)</li> <li>• Common No. 1 tool set (Item 2, Appendix B)</li> </ul> | <ul style="list-style-type: none"> <li>• Cotter pin (2), MS24665-633 (M101A2, M101A3, M1 16A2)</li> <li>• Cotter pin (2), MS24665-357 (M1 16A2E1 and M116A3)</li> <li>• Lubrication fitting (2), MS15001-1</li> <li>• Self-locking nut (8), MS17829-6F (4 for rear spring hanger, 4 for front spring hanger)</li> <li>• Self-locking nut, MS51922-49 (front spring hanger)</li> </ul> |
|--|---|

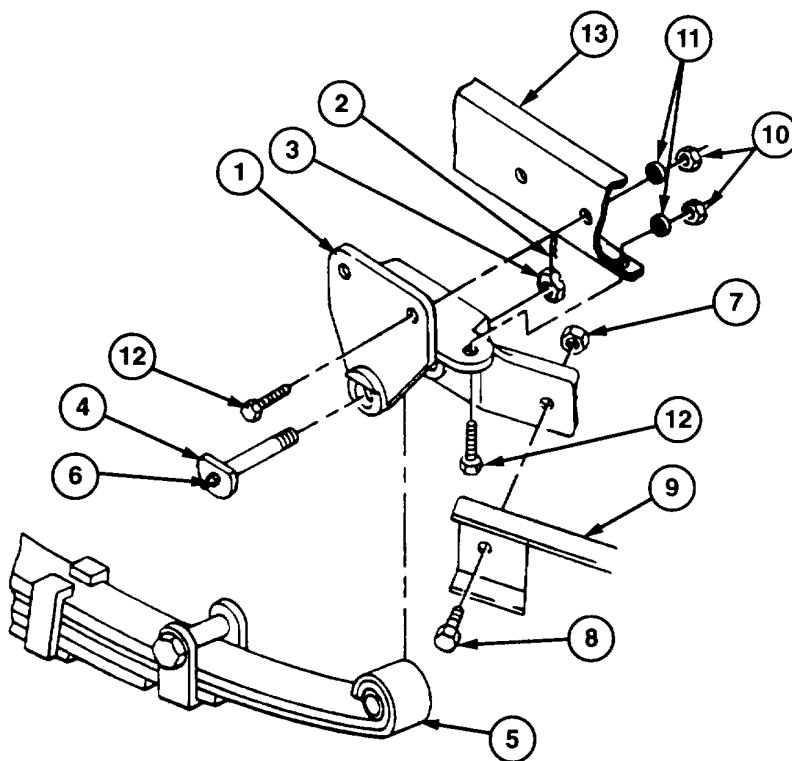
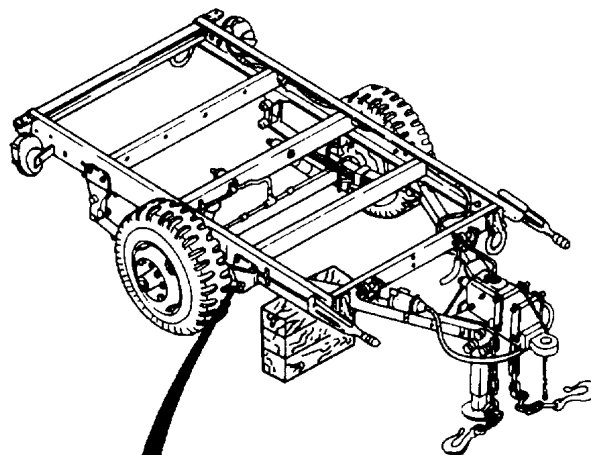
**Materials/Parts:**

- Rag (Item 13, Appendix F)
- Solvent, drycleaning (Item 15, Appendix F)

**4-47. SPRING HANGER REPLACEMENT (continued).**

**a. FRONT SPRING HANGER REMOVAL**

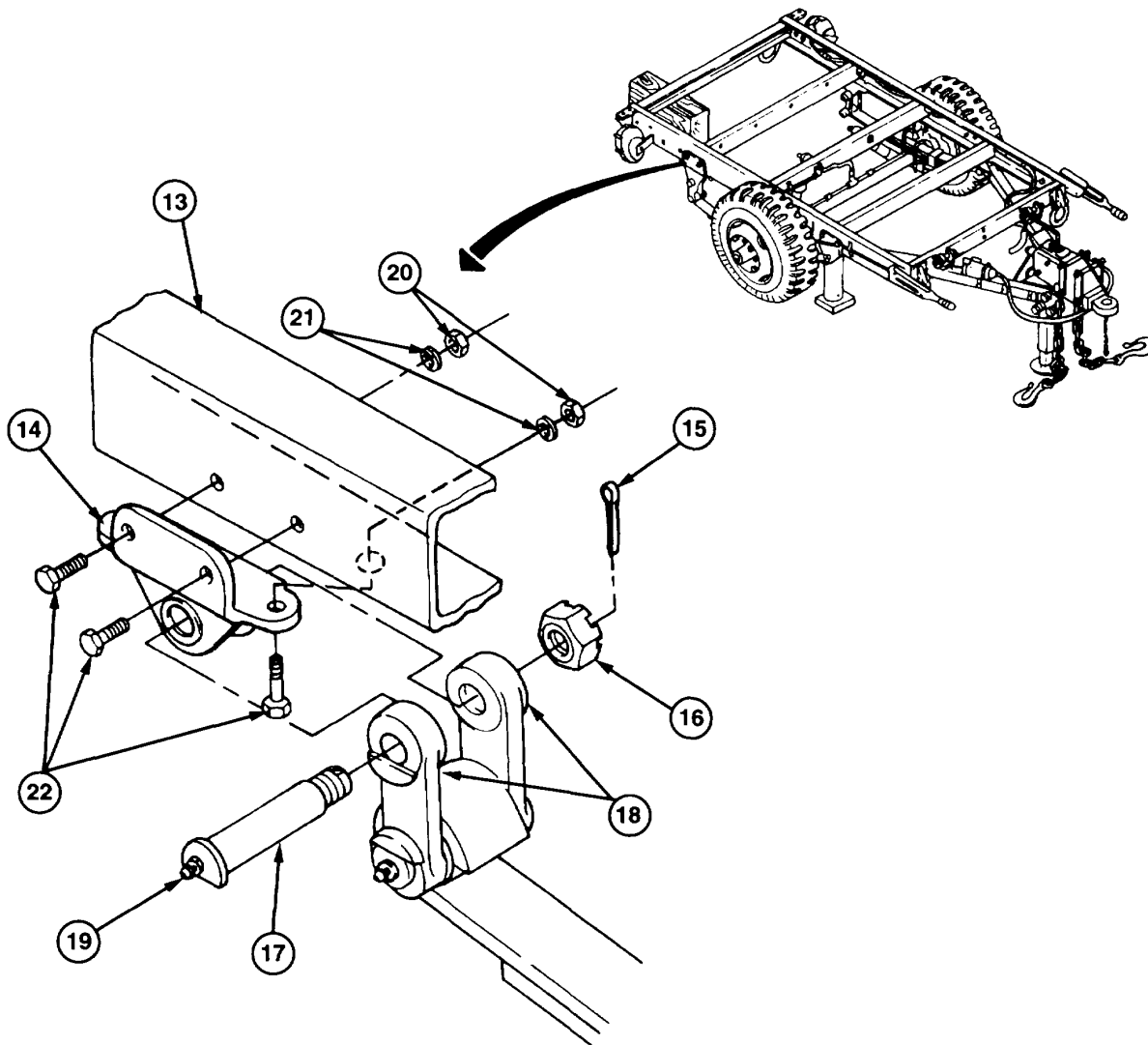
1. Place floor jack under vehicle on side where front spring hanger (1) is being removed. Use floor jack to raise trailer. Place suitable support under front corner of vehicle.
2. Lower vehicle until weight of trailer rests on support at the front corner. Some weight will be on floor jack.
3. Remove cotter pin (2), slotted nut (3), and shackle pin (4) from spring (5) and front spring hanger (1). Remove lubrication fitting (6) from shackle pin (4). Discard cotter pin and lubrication fitting.
4. Lower floor jack until spring (5) is clear of front spring hanger (1).
5. Remove self-locking nut (7) and capscrew (8) from drawbar (9) and front spring hanger (1). Discard self-locking nut.
6. Remove four self-locking nuts (10), washers (11), and capscrews (12) and front spring hanger (1) from frame (13). Discard self-locking nuts.



**4-47. SPRING HANGER REPLACEMENT (continued).**

**b. REAR SPRING HANGER REMOVAL**

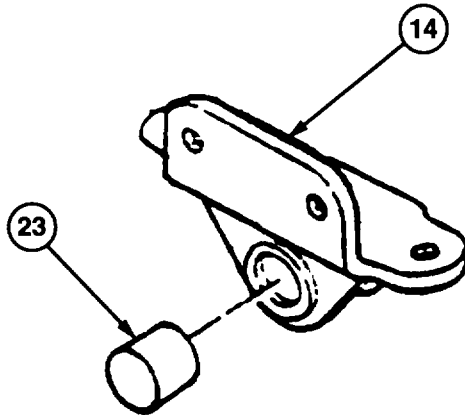
1. Place floor jack under vehicle on side where rear spring hanger (14) is being removed. Use floor jack to raise trailer. Place suitable support under rear corner of vehicle.
2. Lower vehicle until weight of trailer rests on support at the rear corner. Some weight will be on floor jack.
3. Remove cotter pin (15), slotted nut (16), and shackle pin (17) from shackle (18) and rear spring hanger (14). Remove lubrication fitting (19) from shackle pin (17). Discard cotter pin and lubrication fitting.
4. Lower floor jack until shackle (18) is clear of rear spring hanger (14).
5. Remove four self-locking nuts (20), washers (21), and capscrews (22) and rear spring hanger (14) from frame



**447. SPRING HANGER REPLACEMENT (continued).****NOTE**

Remove bushing only if damaged.

6. Remove bushing (23) from rear spring hanger (14).

**c. CLEANING AND INSPECTION****c. CLEANING AND INSPECTION****WARNING**

**Drycleaning solvent P-D-680 is toxic and flammable. Always wear protective goggles and gloves, and use only in a well-ventilated area. Avoid contact with skin, eyes, and clothes, and DO NOT breathe vapors. DO NOT use near open flame or excessive heat.**

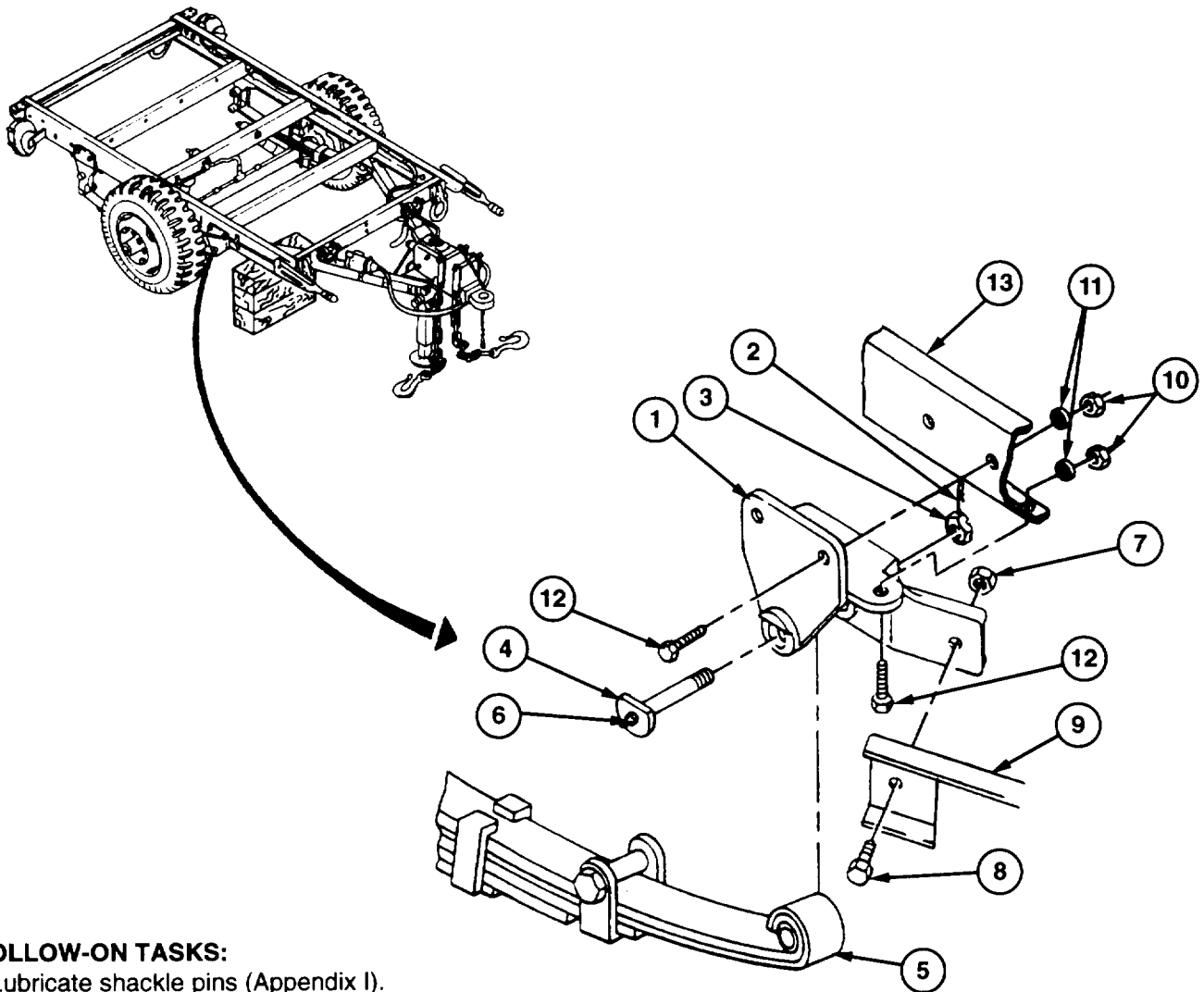
1. Clean all removed components with drycleaning solvent and rag and allow to dry. Make sure lubrication passages in shackle pins are free of grease.
2. Inspect all removed components for cracks, breaks, corrosion, and damaged threads. Replace if damaged.

**d. REAR SPRING HANGER INSTALLATION**

1. If removed, install bushing (23) in rear spring hanger (14).
2. Install rear spring hanger (14) on frame (13) with four capscrews (22), washers (21), and new self-locking nuts (20). Torque self-locking nuts to 30 lb-ft (41 N•m).
3. Use floor jack to raise vehicle until shackle (18) is aligned with rear spring hanger (14).
4. Install shackle pin (17) through shackle (18) and rear spring hanger (14).
5. Install slotted nut (16) on shackle (18) and tighten. Install new cotter pin (15) on shackle (18).
6. Install new lubrication fitting (19) in shackle pin (17).
7. Remove support from rear corner of vehicle. Remove floor jack from under vehicle.

**4-47. SPRING HANGER REPLACEMENT (continued).****e. FRONT SPRING HANGER INSTALLATION**

1. Install front spring hanger (1) on frame (13) with four capscrews (12), washers (11), and new self-locking nuts (10). Torque self-locking nuts to 30 lb-ft (41 N•m).
2. Install drawbar (9) on front spring hanger (1) with capscrew (8) and new self-locking nut (7). Torque self-locking nut between 140 and 150 lb-ft (190-203 Nom).
3. Use floor jack to raise vehicle until spring (5) is aligned with front spring hanger (1).
4. Install shackle pin (4) through spring (5) and front spring hanger (1).
5. Install slotted nut (3) on shackle pin (4) and tighten. Install new cotter pin (2) on shackle pin (4).
6. Install new lubrication fitting (6) in shackle pin (4).
7. Remove support from front corner of vehicle. Remove floor jack from under vehicle.

**FOLLOW-ON TASKS:**

- Lubricate shackle pins (Appendix I).

**4-48. LIFT SHACKLE REPLACEMENT.***This Task Covers:*

- a. Removal b. Installation

*Initial Setup:***Tools/Test Equipment:**

General mechanic's tool kit (Item 1, Appendix B)

**Materials/Parts:**

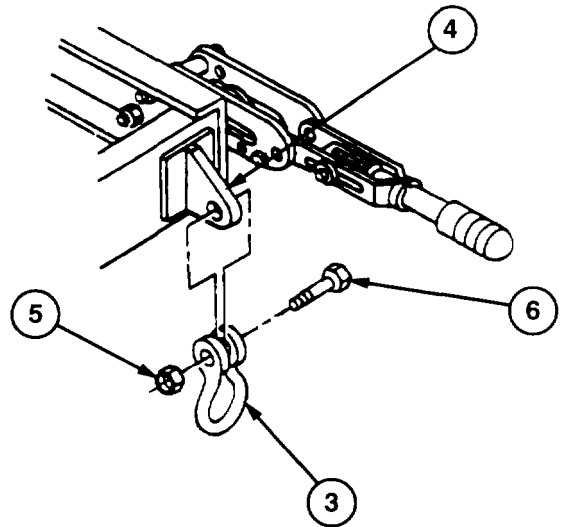
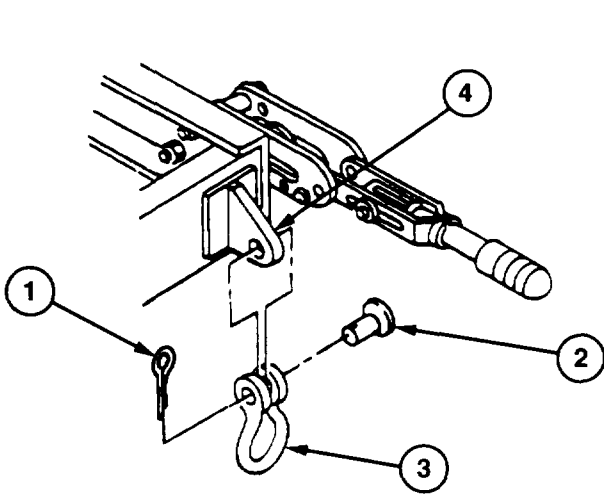
- Cotter pin, MS24665-355
- Self-locking nut, MS51922-57

**a. REMOVAL**

1. On the M101A2 and M116A2, remove cotter pin (1), straight headed pin (2), and lift shackle (3) from bracket (4). Discard cotter pin.
2. On the M101A3, M116A2E1, and M1 16A3, remove self-locking nut (5), capscrew (6), and lift shackle (3) from bracket (4). Discard self-locking nut.

**b. INSTALLATION**

1. On the M101A2 and M116A2, install lift shackle (3) on bracket (4) with straight headed pin (2) and new cotter pin (1).
2. On the M101A3, M116A2E1, and M116A3, install lift shackle (3) on bracket (4) with capscrew (6) and new self-locking nut (5).



---

**4-49. EYEBOLT REPLACEMENT.**

---

*This Task Covers:*

- a. Removal b. Installation
- 

*Initial Setup:*

**Tools/Test Equipment:**

- General mechanic's tool kit (Item 1, Appendix B)

**Materials/Parts:**

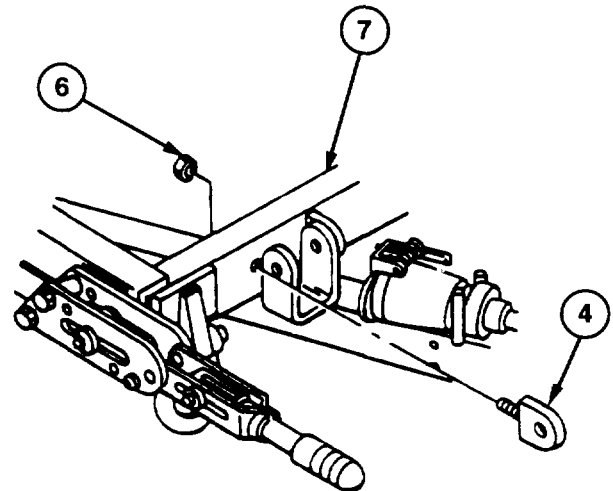
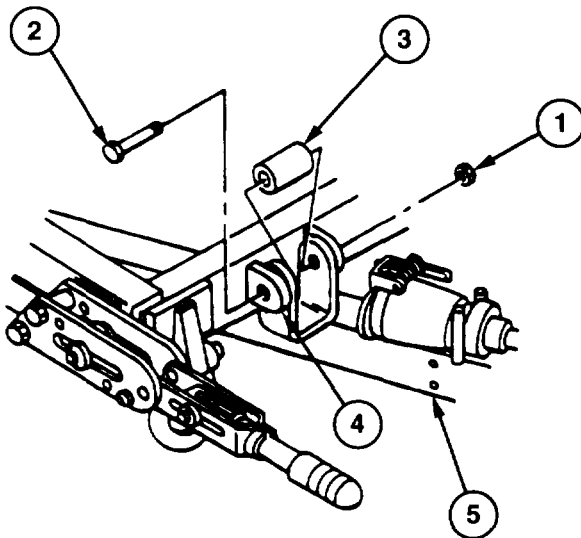
- Self-locking nut (2), MS21044-N8
- 

**a. REMOVAL**

1. Remove self-locking nut (1), capscrew (2), and spacer (3) from eyebolt (4) and drawbar (5). Discard self-locking nut.
2. Remove self-locking nut (6) and eyebolt (4) from frame (7). Discard self-locking nut.

**b. INSTALLATION**

1. Install eyebolt (4) on frame (7) with new self-locking nut (6).
2. Install spacer (3), capscrew (2), and new self-locking nut (1) on eyebolt (4) and drawbar (5).



**FOLLOW-ON TASKS:**

- None



**4-50. DRAWBAR REPLACEMENT.***This Task Covers:*

- |    |         |    |              |
|----|---------|----|--------------|
| a. | Removal | b. | Installation |
|----|---------|----|--------------|

*Initial Setup:***Tools/Test Equipment:**

General mechanic's tool kit (Item 1, Appendix B)  
Common No. 1 tool set (Item 2, Appendix B)

**Materials/Parts:**

- Self-locking nut, MS21044-N8
- Self-locking nut, MS51922-49

**Equipment Conditions:**

- Hydraulic brake actuator assembly removed (para 4-38).

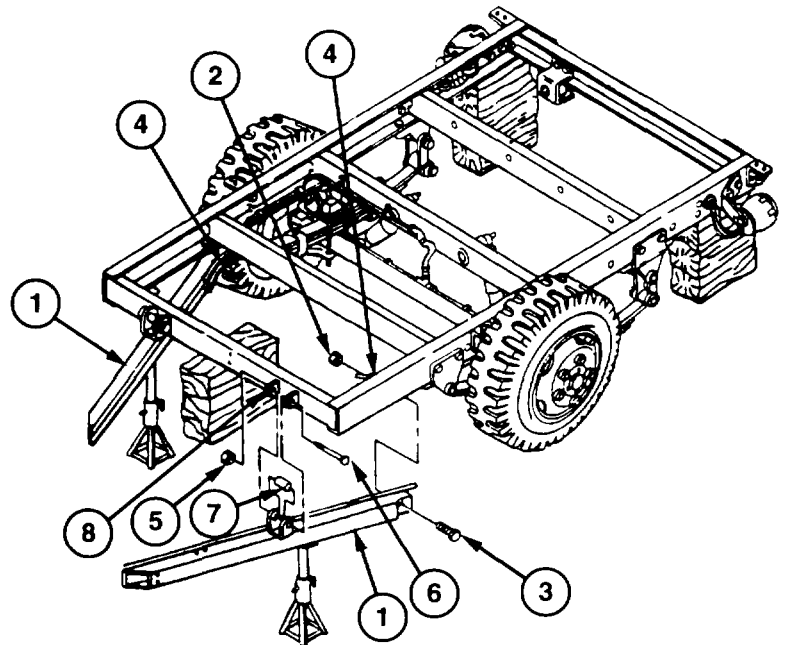
- Intervehicular cable removed from road-side drawbar (para 4-30).
- Chassis wiring harness removed from road-side drawbar, if removing road-side drawbar (para 4-29).
- Hydraulic brake lines removed from curb-side drawbar, if removing curb-side drawbar (para 4-40).

**NOTE**

The procedure for removing and installing drawbars is the same for left side and right side.

**a. REMOVAL**

1. Raise trailer and place suitable support at rear corners and at midpoint of vehicle.
2. Place jackstand under drawbar (1) being removed.
3. Remove self-locking nut (2) and capscrew (3) from drawbar (1) and front spring hanger (4). Discard self-locking nut.
4. Remove self-locking nut (5), capscrew (6), and spacer (7) from drawbar (1) and two eyebolts (8). Discard self-locking nut.

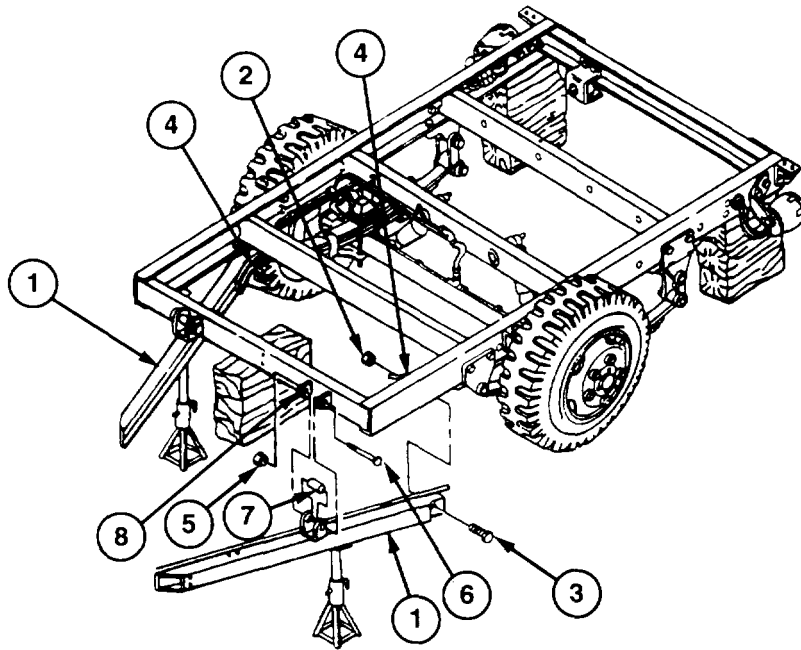


**4-50. DRAWBAR REPLACEMENT (continued).**

5. Pull drawbar (1) forward, away from vehicle, and remove.
6. If replacing drawbar (1), remove data plate (para 4-63).

**b. INSTALLATION**

1. If removed, install data plate (para 4-63).
2. Position drawbar (1) under frame and support with jackstand.
3. Loosely install drawbar (1) on two eyebolts (8) with spacer (7), capscrew (6), and new self-locking nut (5). Torque self-locking nut (5) between 35 and 40 lb-ft (47-54 N•m).
4. Loosely install drawbar (1) on front spring hanger (4) with capscrew (3) and new self-locking nut (2). Torque self-locking nut (2) between 140 and 150 lb-ft (190-203 N•m).
5. Remove supports from rear of vehicle.

**FOLLOW-ON TASKS:**

- Install hydraulic brake lines on curb-side drawbar, if installing curb-side drawbar (para 4-40).
- Install chassis wiring harness on road-side drawbar, if installing road-side drawbar (para 4-29).
- Install Intervehicular cable on road-side drawbar (para 4-30).
- Install hydraulic brake actuator assembly (para 4-38).

## 4-51. ADJUSTABLE FRONT SUPPORT LEG REPLACEMENT.

*This Task Covers:*

- |                 |                            |
|-----------------|----------------------------|
| a. Removal      | b. Cleaning and Inspection |
| c. Installation |                            |

*Initial Setup:*

### Tools/Test Equipment:

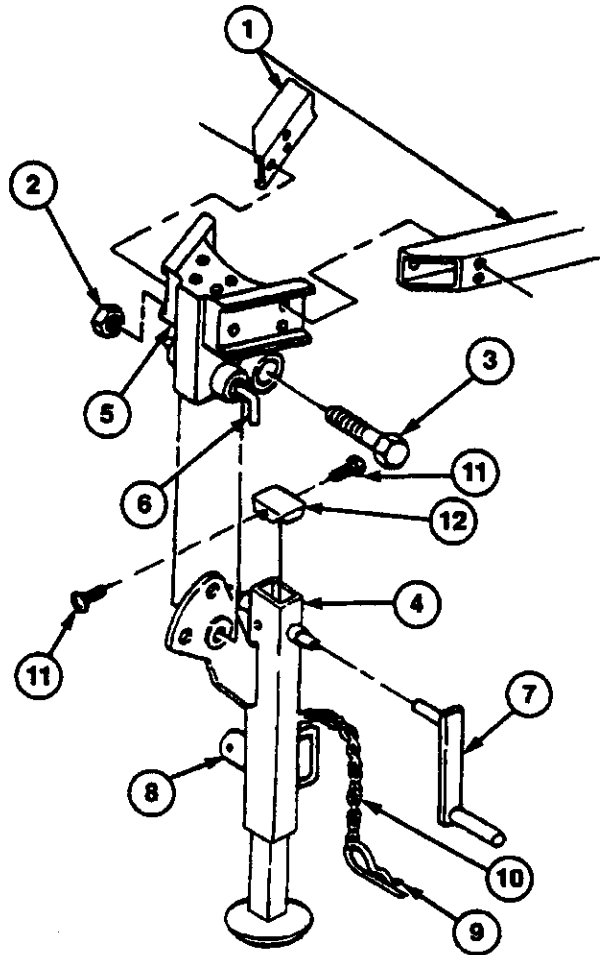
- General mechanic's tool kit (Item 1, Appendix B)
- Common No. 1 tool set (Item 2, Appendix B)

### Materials/Parts:

- Grease (Item 7, Appendix F)
- Rag (Item 13, Appendix F)
- Solvent, drycleaning (Item 15, Appendix F)
- Self-locking nut, MS51922-61

### a. REMOVAL

1. Place jackstand under both drawbars (1) to support front of trailer.
2. Remove self-locking nut (2) and capscrew (3) from adjustable front support leg (4) and bracket and plunger assembly (5). Discard self-locking nut.
3. Pull out on plunger (6) and remove adjustable front support leg (4) from bracket and plunger assembly (5).
4. Remove handcrank (7) from stowage bracket (8) by removing cotter pin (9) from stowage bracket (8).
5. If damaged, remove cotter pin (9) from chain (10). Discard cotter pin.
6. Remove two screws (11) and cap (12) from adjustable front support leg (4).



**4-51. ADJUSTABLE FRONT SUPPPORT LEG REPLACEMENT (continued).**

**b. CLEANING AND INSPECTION**

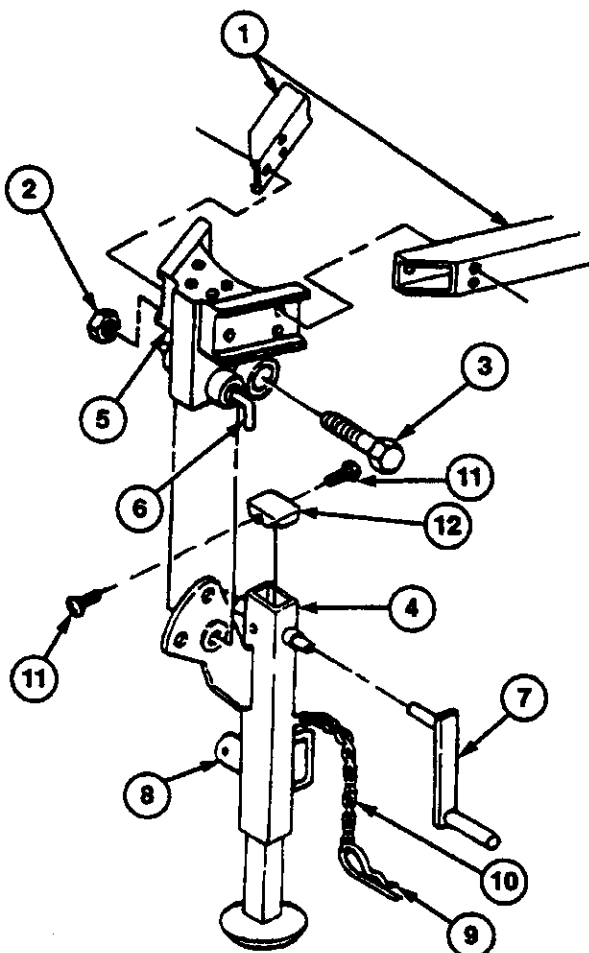
**WARNING**

Drycleaning solvent P-D-680 is toxic and fammable. Always wear protective goggles and gloves, and use only in a well-ventilated area. Avoid contact with skin, eyes, and clothes, and DO NOT breathe vapors. DO NOT use near open flame or excessive heat.

1. Clean all removed components with drycleaning solvent and rag and allow to dry.
2. Inspect all components for wear, cracks, broken welds, or corrosion. Replace if damaged.

**c. INSTALLATION**

1. Fill cavity of adjustable front support leg (4) with grease. Install cap (12) on adjustable front support leg (4) with two screws (11).
2. If removed, install new cotter pin (9) on chain (10).
3. Pull out plunger (6) and position adjustable front support leg (4) at bracket and plunger assembly (5). Push in plunger to hold leg.
4. Install capscrew (3) and new self-locking nut (2) on adjustable front support leg (4) and bracket and plunger assembly (5).
5. Use handcrank (7) to make sure adjustable front support leg (4) is in fully lowered position. Push in plunger (6) to lock it in position.
6. Stow handcrank (7) on stowage bracket (8) with cotter pin (9).
7. Remove jackstands from both drawbars (1).



**FOLLOW-ON TASKS:**

- None

**4-52. SAFETY CHAINS REPLACEMENT.***This Task Covers:*

- a. Removal b. Installation

*Initial Setup:*

Tools/Test Equipment:

- General mechanic's tool kit (Item 1, Appendix B)
- Common No. 1 tool set (Item 2, Appendix B)

Materials/Parts:

- Self-locking nut, MS51922-61

**NOTE**

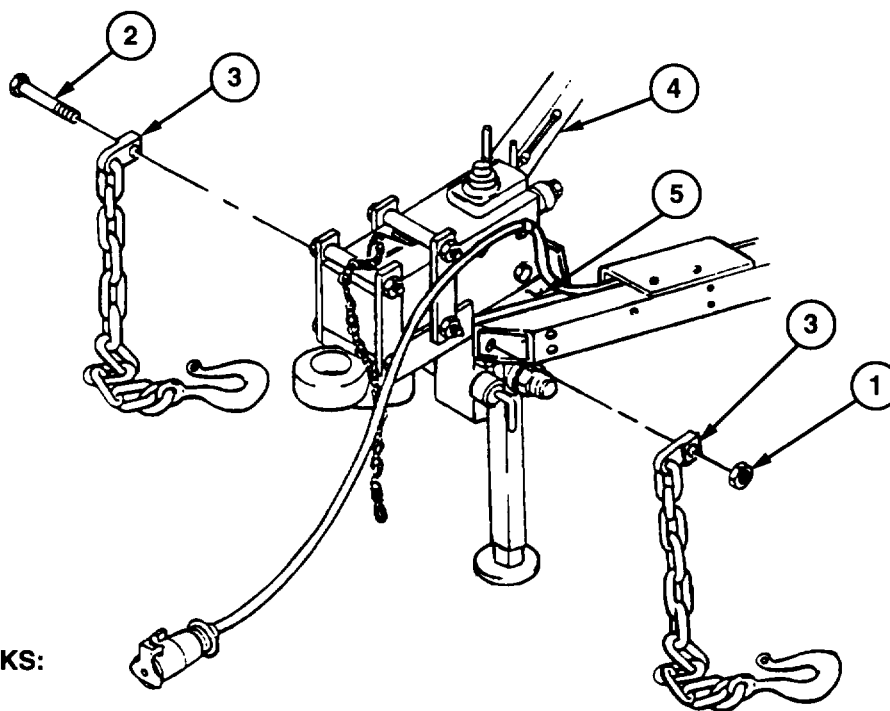
Mounting capscrew for safety chains passes through hydraulic brake actuator assembly components.

**a. REMOVAL**

Remove self-locking nut (1), capscrew (2), and two safety chains (3) from two drawbars (4) and drawbar bracket assembly (5). Discard self-locking nut.

**b. INSTALLATION**

Install two safety chains (3) on two drawbars (4) and drawbar bracket assembly (5) with capscrew (2) and new self-locking nut (1). Torque self-locking nut between 165 and 175 lb-ft (224-237 N•m).

**FOLLOW-ON TASKS:**

- None

**Section X. SPRINGS AND SHOCK ABSORBERS MAINTENANCE**

Paragraph Number	Paragraph Title	Page Number
4-53	General .....	4-104
4-54	Spring Assembly Replacement.....	4-104
4-55	Shock Absorbers Replacement .....	4-108

**4-53. GENERAL.**

This section describes and illustrates removal and installation procedures for the spring assemblies and shock absorbers.

**4-54. SPRING ASSEMBLY REPLACEMENT.**

*This Task Covers:*

- a. Removal
- b. Cleaning and Inspection
- c. Installation

*Initial Setup:*

**Tools/Test Equipment:**

General mechanic's tool kit (Item 1, Appendix B)  
 Common No. 1 tool set (Item 2, Appendix B)

- Cotter pin (3), MS24665-633 (M101A2 and M116A2)
- Lubrication fitting (3), MS15001-1
- Self-locking nut (4), MS21044-N8

**Materials/Parts:**

- removed (para 4-44).
- 
- 

**Equipment Conditions:**

- Rag (Item 13, Appendix F)•Wheel and tire assembly
- Solvent, drycleaning (Item 15, Appendix F)
- Cotter pin (3), MS24665-357 (M101A3, M116A2E1,• Personnel Required: Two and M116A3)

**WARNING**

**Use extreme caution when handling heavy parts. Lifting device is required when parts weigh over 50 pounds (23 kg) for a single-person lift, over 100 pounds (45 kg) for a two-person lift, and over 150 pounds (68 kg) for a three-person or more lift. Keep clear of heavy parts supported only by lifting device. Failure to follow this warning may cause serious injury or death to personnel.**

**a. REMOVAL**

1. Place floor jack under axle (1), raise trailer, and place suitable support at rear of trailer.
2. Lower axle (1) until weight of trailer rests on support at rear of trailer. Some weight will be on floor jack.
3. Remove four self-locking nuts (2) and washers (3), two U-bolts (4), and bumper (5) from axle (1) and spring assembly (6). Discard self-locking nuts.
4. Remove screw (7) from handbrake cable clip (8) on frame (9).

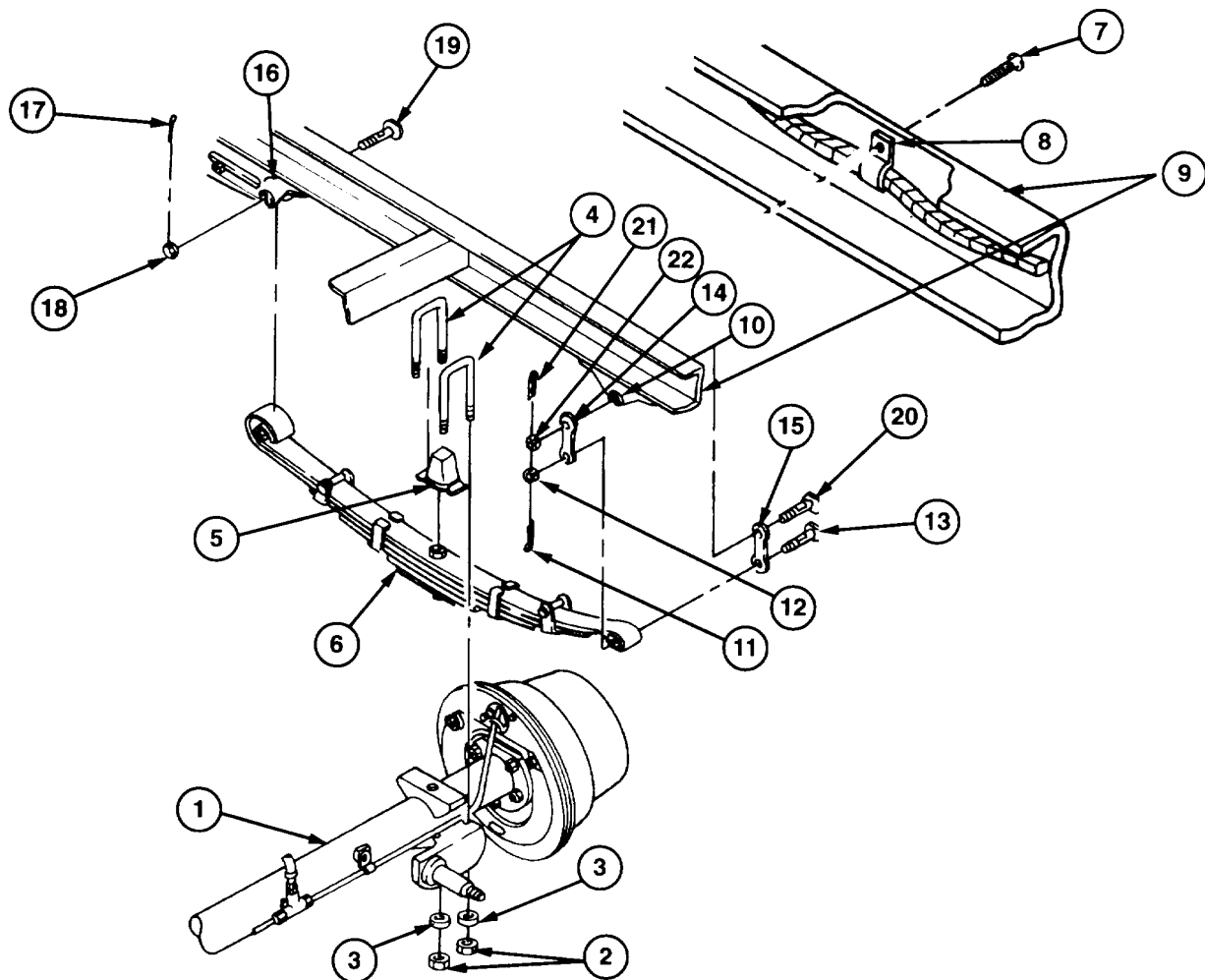
**4-54. SPRING ASSEMBLY REPLACEMENT (continued).**

5. Lower axle (1) approximately 4 inches (10 cm) to take weight off spring assembly (6).
6. At rear spring hanger (10), remove cotter pin (11), slotted nut (12), and shackle pin (13) from two shackles (14 and 15) and, with the aid of an assistant, remove spring assembly (6). Discard cotter pin.
7. At front spring hanger (16), remove cotter pin (17), slotted nut (18), and shackle pin (19) from front spring hanger (16) and spring assembly (6). Discard cotter pin.
8. Remove spring assembly (6) from frame (9).

**NOTE**

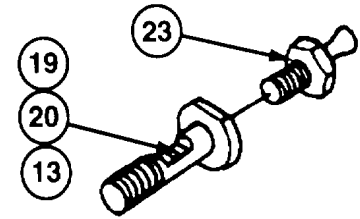
Shackle pin should fit in rear spring hanger with slight resistance.

9. At rear spring hanger (10), check play between shackle pin (20) and rear spring hanger (10). Looseness indicates a damaged shackle pin (20) inside rear spring hanger (step 11).
10. Remove cotter pin (21), slotted nut (22), shackle pin (20), and two shackles (14 and 15) from rear spring hanger (10). Discard cotter pin.



**4-54. SPRING ASSEMBLY REPLACEMENT (continued).**

11. Remove lubrication fitting (23) from each of three shackle pins (19, 20, and 13) and discard.



**b. CLEANING AND INSPECTION**

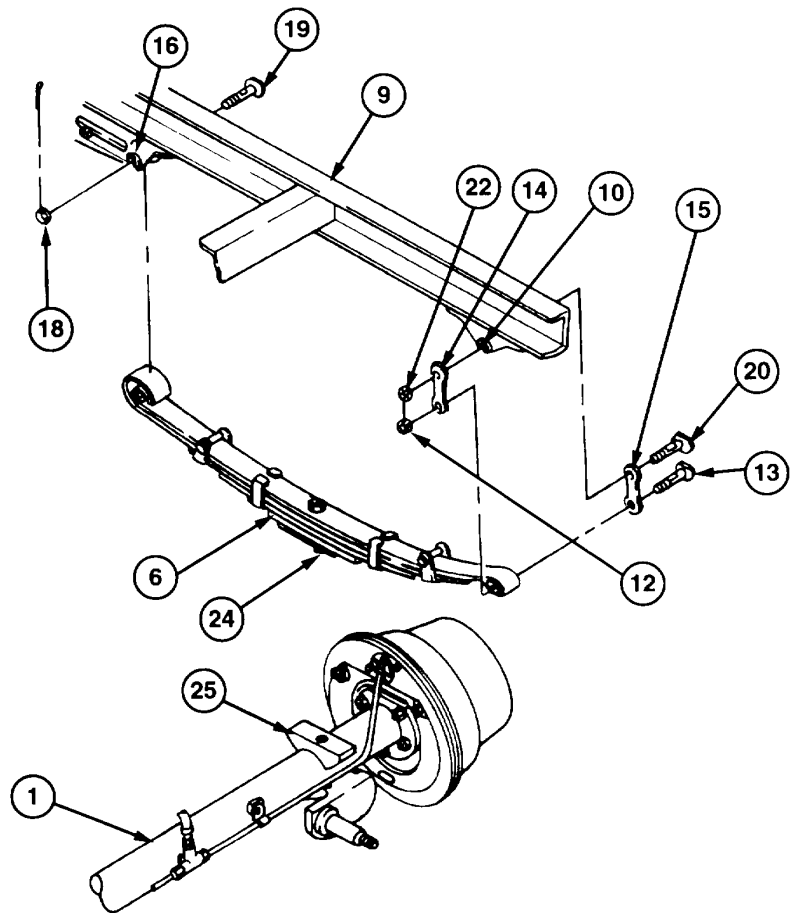
**WARNING**

**Drycleaning solvent P-D-680 is toxic and flammable. Always wear protective clothing and use only in a well-ventilated area. Avoid contact with skin, eyes, and clothes, and DO NOT breathe vapors. DO NOT use near open flame or excessive heat.**

1. Clean all removed components with drycleaning solvent and rag and allow to dry. Make sure lubrication passages in shackle pins are clear.
2. Inspect all removed components for cracks, breaks, corrosion, or damaged threads. Replace if damaged.

**c. INSTALLATION**

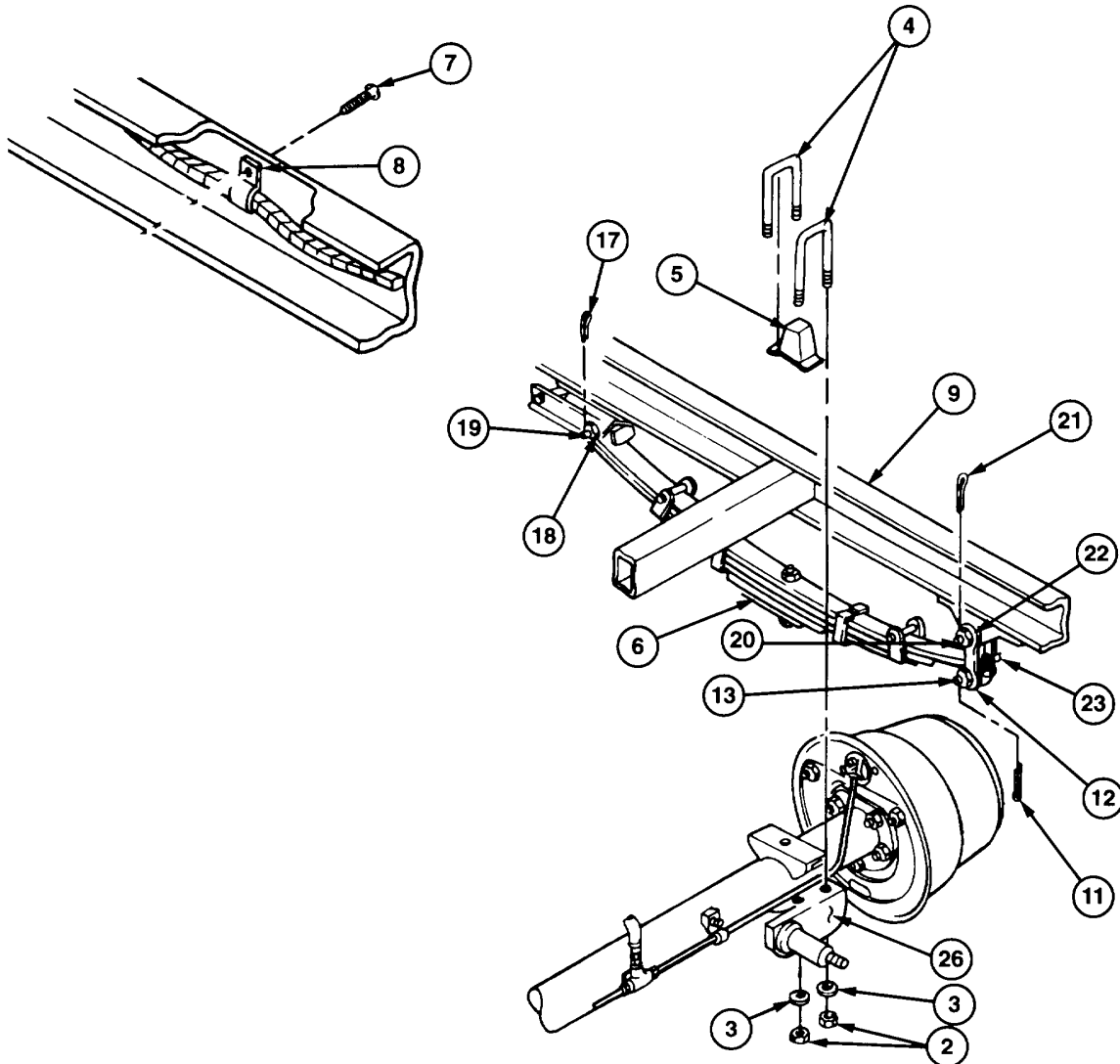
1. Loosely install two shackles (14 and 15) on rear spring hanger (10) with shackle pin (20) and slotted nut (22).
2. Position spring assembly (6) above axle (1).
3. At front spring hanger (16), loosely install spring assembly (6) on frame (9) with shackle pin (19) and slotted nut (18).
4. At rear spring hanger (10), loosely install spring assembly (6) on two shackles (14 and 15) with shackle pin (13) and slotted nut (12).
5. Use floor jack to raise axle (1) until it contacts underside of spring assembly (6). Engage spring assembly center bolt head (24) with hole in spring mounting pad (25).





**4-54. SPRING ASSEMBLY REPLACEMENT (continued).**

6. Install bumper (5) on spring assembly (6). Install two U-bolts (4) into grooves of bumper (5) and through holes in spring plate (26).
7. Install four washers (3) and new self-locking nuts (2) on two U-bolts (4).
8. Tighten slotted nuts (22, 12, and 18).
9. Align holes for three cotter pins (17, 21, and 11) with slots in slotted nuts (22, 12, and 18) and install three new cotter pins (17, 21, and 11).
10. Install new lubrication fitting (23) in each of three shackle pins (19, 20, and 13).
11. Install screw (7) into handbrake cable clip (8) on frame (9) and tighten.

**FOLLOW-ON TASKS:**

- Lubricate shackle pins (Appendix I).
- Install wheel and tire assembly (para 4-44).

---

**4-55. SHOCK ABSORBERS REPLACEMENT.**

---

*This Task Covers:*

- |                 |                            |
|-----------------|----------------------------|
| a. Removal      | b. Cleaning and Inspection |
| c. Installation |                            |
- 

*Initial Setup:*

**Tools/Test Equipment:**

- General mechanic's tool kit (Item 1, Appendix B)
- Common No. 1 tool set (Item 2, Appendix B) and M116A2)

•Rag (Item 13, Appendix F)

- Solvent, drycleaning (Item 15, Appendix F)
- Self-locking nut (2), MS21044N10 (M101A2, M101A3,

**Materials/Parts:**

Detergent (Item 5, Appendix F)

- Self-locking nut (2), MS51922-53 (M116A2E1 and M116A3)
- 

**a. REMOVAL**

1. Remove two self-locking nuts (1) from upper and lower mounting studs (2 and 3). Discard self-locking nuts.
2. Remove two recessed washers (4) and bushings (5), shock absorber (6), and two bushings (7) from upper and lower mounting studs (2 and 3).

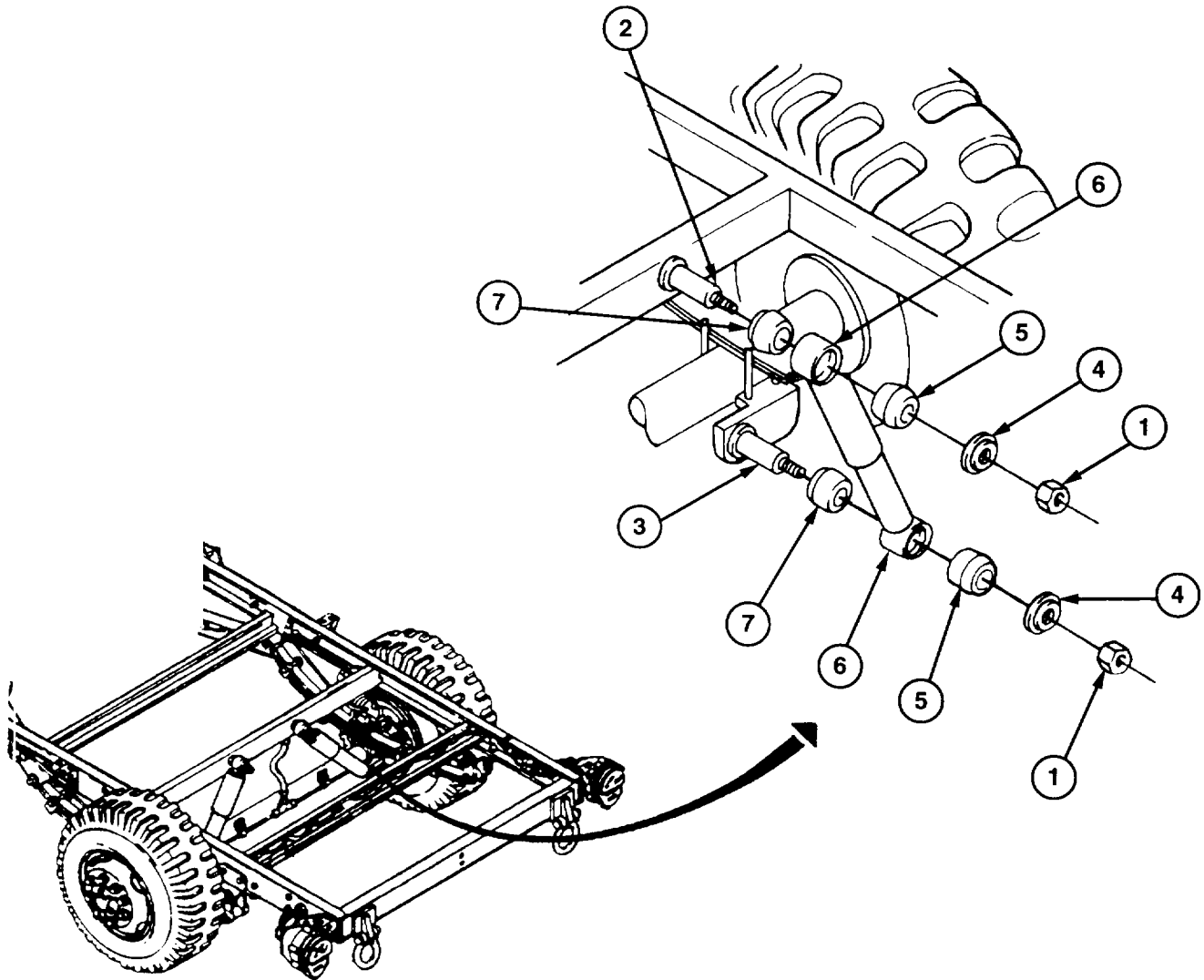
**b. CLEANING AND INSPECTION****WARNING**

**Drycleaning solvent P-D-680 is toxic and flammable. Always wear protective goggles and gloves, and use only in a well-ventilated area. Avoid contact with skin, eyes, and clothes, and DO NOT breathe vapors. DO NOT use near open flame or excessive heat.**

1. Clean upper and lower mounting studs and all mounting hardware except bushings with drycleaning solvent and rag and allow to dry.
2. Clean bushings with detergent and water solution.

**4-55. SHOCK ABSORBERS REPLACEMENT (continued).**

3. Inspect upper and lower mounting studs for cracks, bends, or bad threads. Notify Direct Support maintenance if damaged.
  4. Replace all damaged components.
- c. INSTALLATION**
1. Install two bushings (7), shock absorber (6) with thicker dust shield end at top, and two bushings (5) on upper and lower mounting studs (2 and 3).
  2. Install two recessed washers (4) and new self-locking nuts (1) on upper and lower mounting studs (2 and 3). Torque self-locking nuts between 20 and 25 lb-ft (27-34 N•m).

**FOLLOW-ON TASKS:**

- None

Section XI. BODY MAINTENANCE

Paragraph Number	Paragraph Title	Page Number
4-56	General .....	4-110
4-57	Cargo Body Replacement (M101A2 and M101A3).....	4-110
4-58	Tailgate Replacement (M101A2 and M101A3).....	4-113
4-59	U-Bolt Replacement (M101A2 and M101A3).....	4-115

**4-56. GENERAL.**

This section describes and illustrates removal and installation procedures for the cargo body, tailgate, and U-bolts.

**4-57. CARGO BODY REPLACEMENT (M101A2 AND M101A3).**

*This Task Covers:*

- a. Removal b. Installation

*Initial Setup:*

**Tools/Test Equipment:**

**Personnel Required:** Two

- General mechanic's tool kit (Item 1, Appendix B)
- Common No. 1 tool set (Item 2, Appendix B)

**Materials/Parts:**

- Self-locking nut (18), MS51922-17

**WARNING**

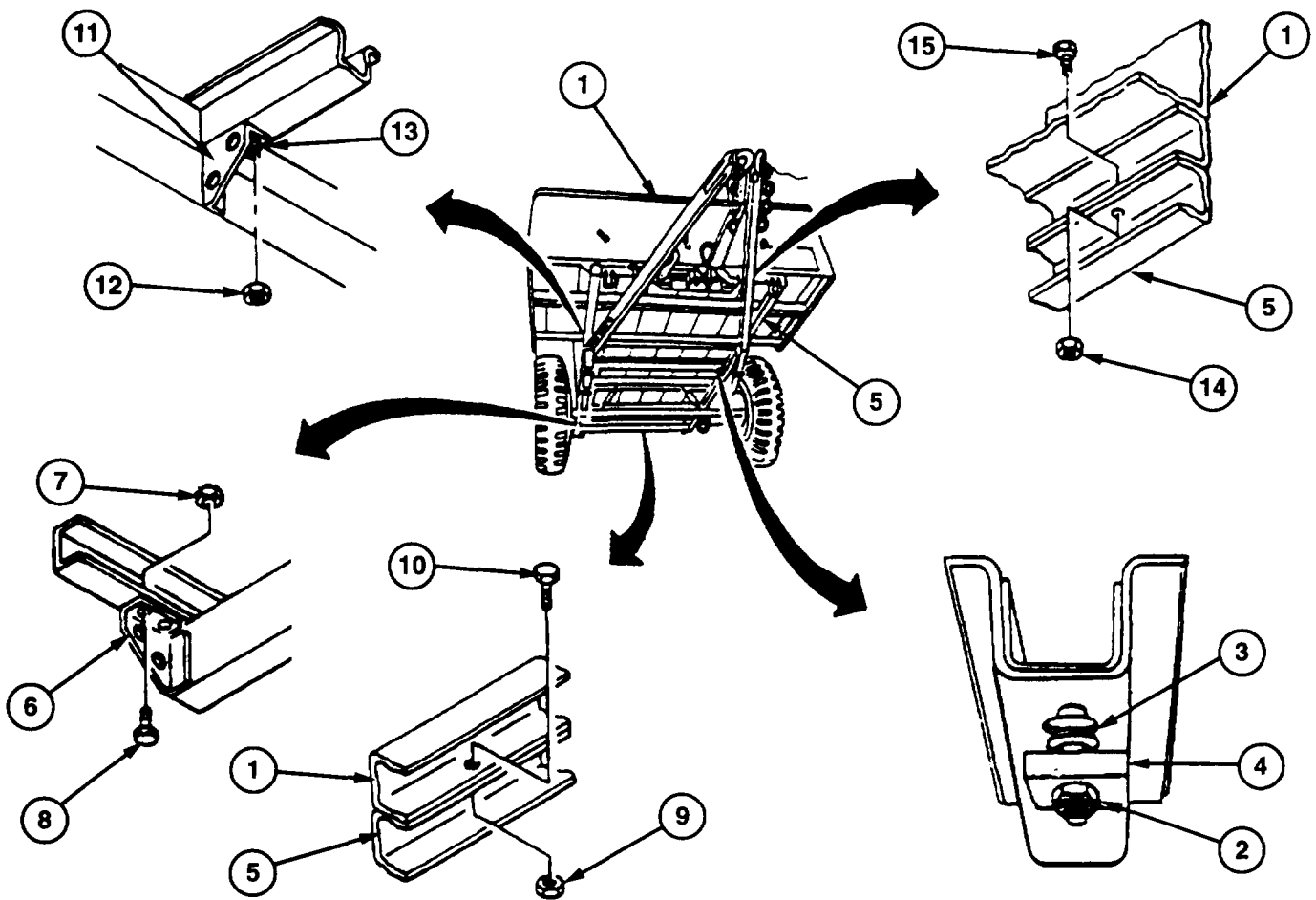
Use extreme caution when handling heavy parts. Lifting device is required when parts weigh over 50 pounds (23 kg) for a single-person lift, over 1 00 pounds (45 kg) for a two-person lift, and over 150 pounds (68 kg) for a three-person or more lift. Keep clear of heavy parts supported only by lifting device. Failure to follow this warning may cause serious injury or death to personnel.

**a. REMOVAL**

1. Attach a suitable lifting device to cargo body (1).

**4-57. CARGO BODY REPLACEMENT (M101A2 AND M101A3) (continued).**

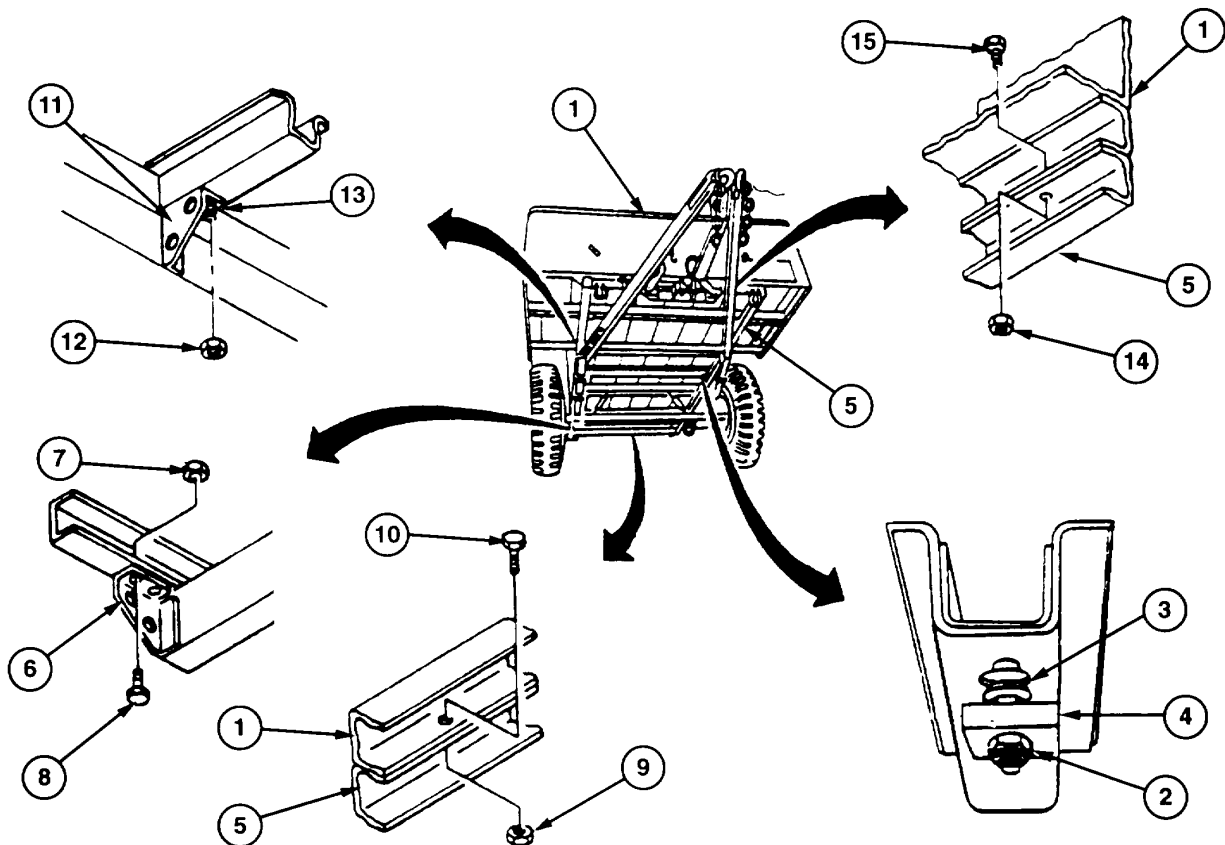
2. Remove eight self-locking nuts (2), square neck bolts (3), and clamps (4) securing cargo body (1) to frame (5). Discard self-locking nuts.
3. At each of two rear corner mounting brackets (6), remove two self-locking nuts (7) and capscrews (8) from mounting bracket (6). Discard self-locking nuts.
4. At rear chassis sill, remove self-locking nut (9) and capscrew (10) from cargo body (1) and frame (5). Discard self-locking nut.
5. At each of two midchassis mounting brackets (11), remove self-locking nut (12) and capscrew (13) from mounting brackets (11). Discard self-locking nuts.
6. At front chassis sill, remove three self-locking nuts (14) and capscrews (15) from cargo body (1) and frame (5). Discard self-locking nuts.
7. With the aid of an assistant, lift cargo body (1) from frame (5). Remove lifting device from cargo body (1).



**4-57. CARGO BODY REPLACEMENT (M101A2 AND M101A3) (continued).**

**b. INSTALLATION**

1. Attach a suitable lifting device to cargo body (1).
2. With the aid of an assistant, lift cargo body (1) onto frame (5) and align mounting holes.
3. At front chassis sill, loosely install three capscrews (15) and new self-locking nuts (14) on cargo body (1) and frame (5).
4. At each of two midchassis mounting brackets (11), loosely install capscrew (13) and new self-locking nut (12) on mounting brackets (11).
5. At rear chassis sill, loosely install capscrew (10) and new self-locking nut (9) on cargo body (1) and frame (5).
6. At each of two rear corner mounting brackets (6), loosely install two capscrews (8) and new self-locking nuts (7) on mounting brackets (6).
7. Insert eight square neck bolts (3), clamps (4), and new self-locking nuts (2) into cargo body (1).
8. Torque 18 self-locking nuts (14, 2, 9, 7, and 12) between 26 and 31 lb-ft (35-42 N•m).
9. Remove lifting device from cargo body (1).



**FOLLOW-ON TASKS:**

- None

---

**4-58. TAILGATE REPLACEMENT (M101A2 AND M101A3).**

---

*This Task Covers:*

- a. Removal b. Installation
- 

*Initial Setup:*

**Tools/Test Equipment:**

**Personnel Required:** Two

- General mechanic's tool kit (Item 1, Appendix B)

**Materials/Parts:**

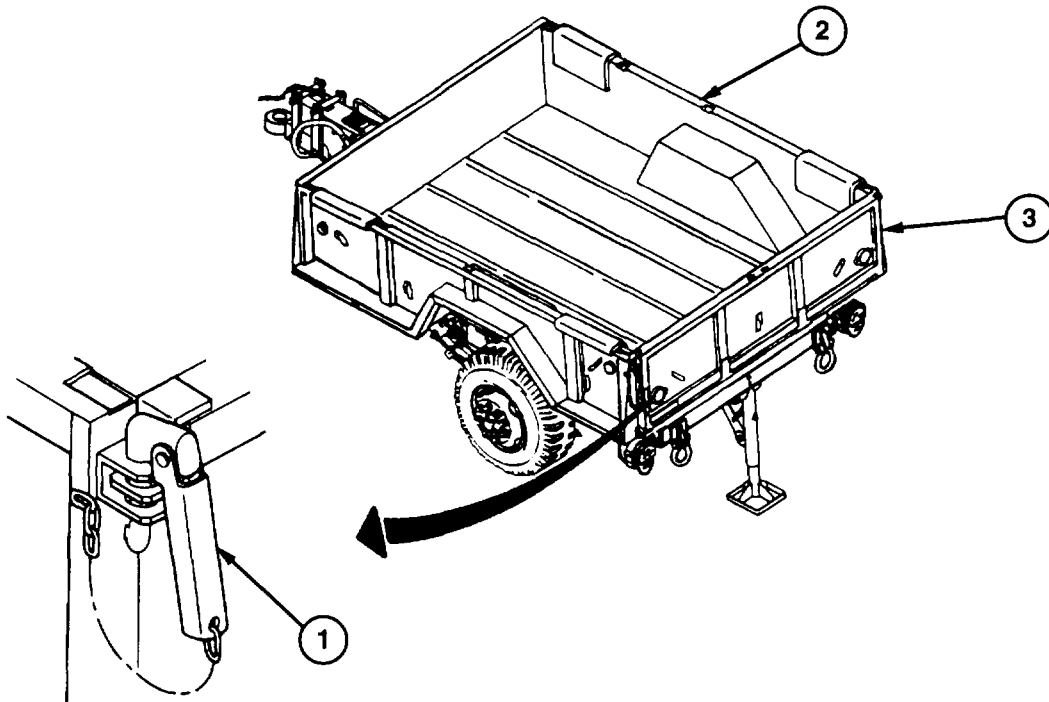
- Cotter pin (4), MS24665-353
- 

**WARNING**

Use extreme caution when handling heavy parts. Lifting device is required when parts weigh over 50 pounds (23 kg) for a single-person lift, over 100 pounds (45 kg) for a two-person lift, and over 150 pounds (68 kg) for a three-person or more lift. Keep clear of heavy parts supported only by lifting device. Failure to follow this warning may cause serious injury or death to personnel.

**a. REMOVAL**

1. Remove two latch pins (1) from cargo body (2) and release top corners of tailgate (3) from cargo body (2).
2. Open and lower tailgate (3) and support it with wood blocks.



---

**4-58. TAILGATE REPLACEMENT (M101A2 AND M101A3) (continued).**


---

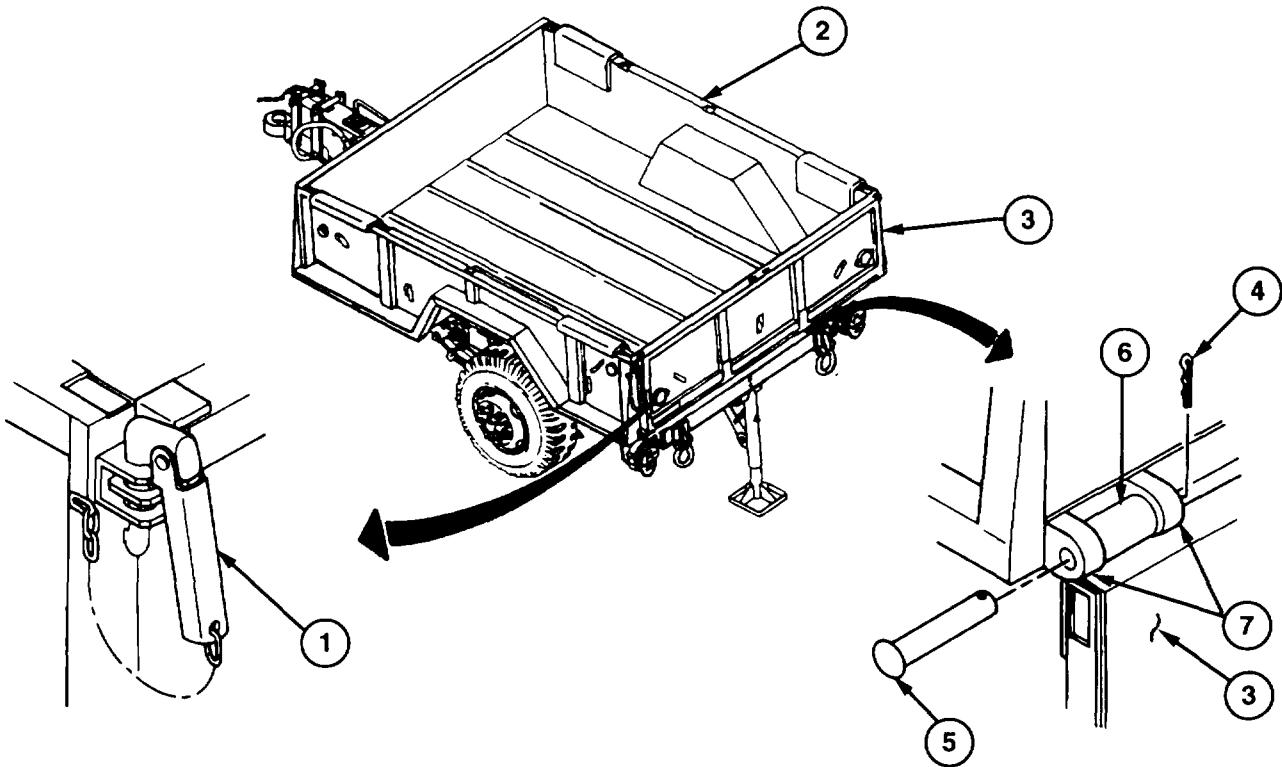
WARNING

**Hold tailgate in place before removing straight headed pins. If tailgate is not properly supported it may fall, causing injury to personnel.**

3. With the aid of an assistant, remove four cotter pins (4) and straight headed pins (5) from four hinges (6) and eyebolts (7). Discard cotter pins.
  4. With the aid of an assistant, remove tailgate (3) from cargo body (2).

**b. INSTALLATION**

1. With the aid of an assistant, position tailgate (3) at cargo body (2) and support tailgate (3) with wood blocks.
2. With the aid of an assistant, align four hinges (6) with eyebolts (7) and install four straight headed pins (5) through hinges (6) with heads facing away from center of tailgate (3).
3. With the aid of an assistant, install four new cotter pins (4) in four straight headed pins (5).
4. Raise tailgate (3) and secure to top corners of cargo body (2) with two latch pins (1).





---

**4-59. U-BOLT REPLACEMENT (M101A2 AND M101A3).**

---

*This Task Covers:*

- a. Removal b. Installation
- 

*Initial Setup:*

**Tools/Test Equipment:**

- General mechanic's tool kit (Item 1, Appendix B)

**Materials/Parts:**

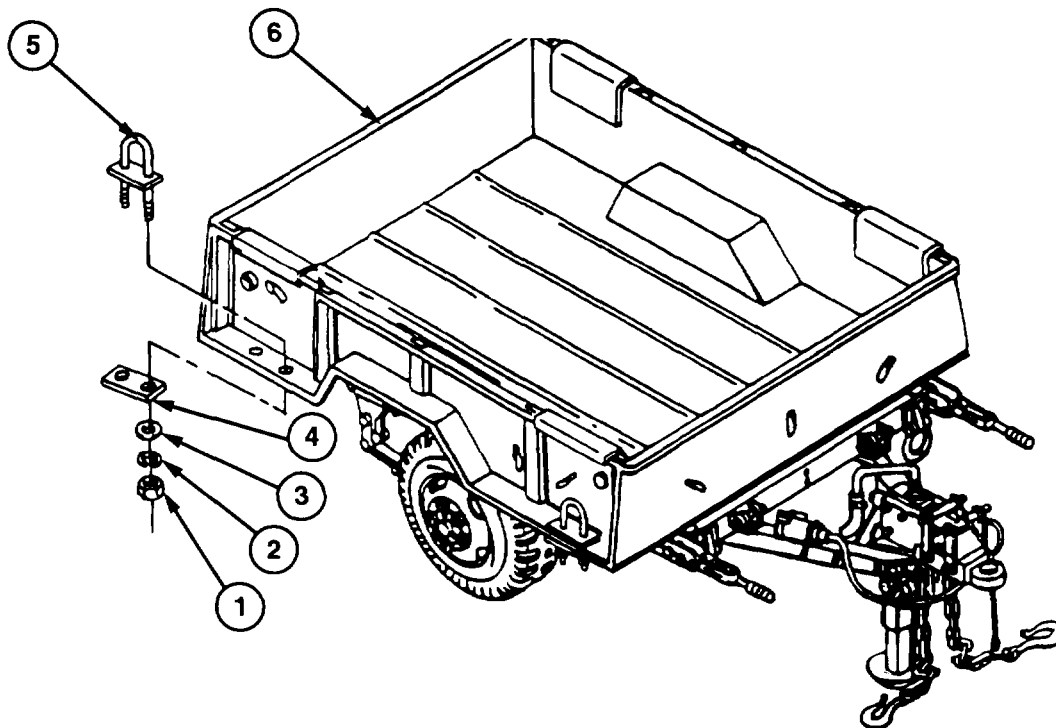
- Lockwasher (2), MS35338-48
- 

**a. REMOVAL**

Remove two nuts (1), lockwashers (2), and washers (3), plate (4), and U-bolt (5) from cargo body (6). Discard lockwashers.

**b. INSTALLATION**

Install U-bolt (5) on cargo body (6) with plate (4) and two washers (3), new lockwashers (2), and nuts (1).

**FOLLOW-ON TASKS:**

- None

Section XII. ACCESSORY ITEMS MAINTENANCE

Paragraph Number	Paragraph Title	Page Number
4-60	General.....	4-116
4-61	Canvas Cover Assembly Grommet and Rope Replacement (M101A2 and M101A3).....	4-116
4-62	Reflector Replacement (M101A2 and M101A3) .....	4-117
4-63	Data Plate Replacement .....	4-118

**4-60. GENERAL.**

This section describes and illustrates removal and installation procedures for the canvas cover assembly grommet and rope, reflectors, and data plates.

**4-61. CANVAS COVER ASSEMBLY GROMMET AND ROPE REPLACEMENT (M101A2 AND M101A3).**

*This Task Covers:*

- a. Removal b. Installation

*Initial Setup:*

**Tools/Test Equipment:**

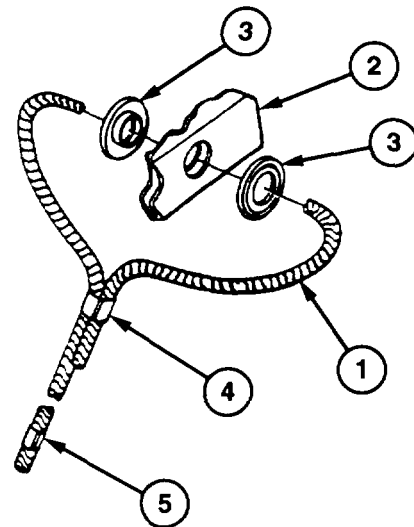
- General mechanic's tool kit (Item 1, Appendix B)

**a. REMOVAL**

1. Cut rope (1) from canvas cover assembly (2). Discard rope.
2. Remove two grommets (3) from canvas cover assembly (2).

**b. INSTALLATION**

1. Install two grommets (3) on canvas cover assembly (2).
2. Feed new rope (1) through two grommets (3) and loop securely around grommets (3). Install clip (4) on rope (1) and crimp.
3. Install end clip (5) on end of rope (1) and crimp.



**FOLLOW-ON TASKS:**

- None

---

**4-62. REFLECTOR REPLACEMENT (M101A2 AND M101A3).**

---

*This Task Covers:*

- a. Removal b. installation
- 

*Initial Setup:*

**Tools/Test Equipment:**

- General mechanic's tool kit (Item 1, Appendix B)

**Materials/Parts:**

- Lockwasher (2), MS35338-44
- 

**a. REMOVAL**

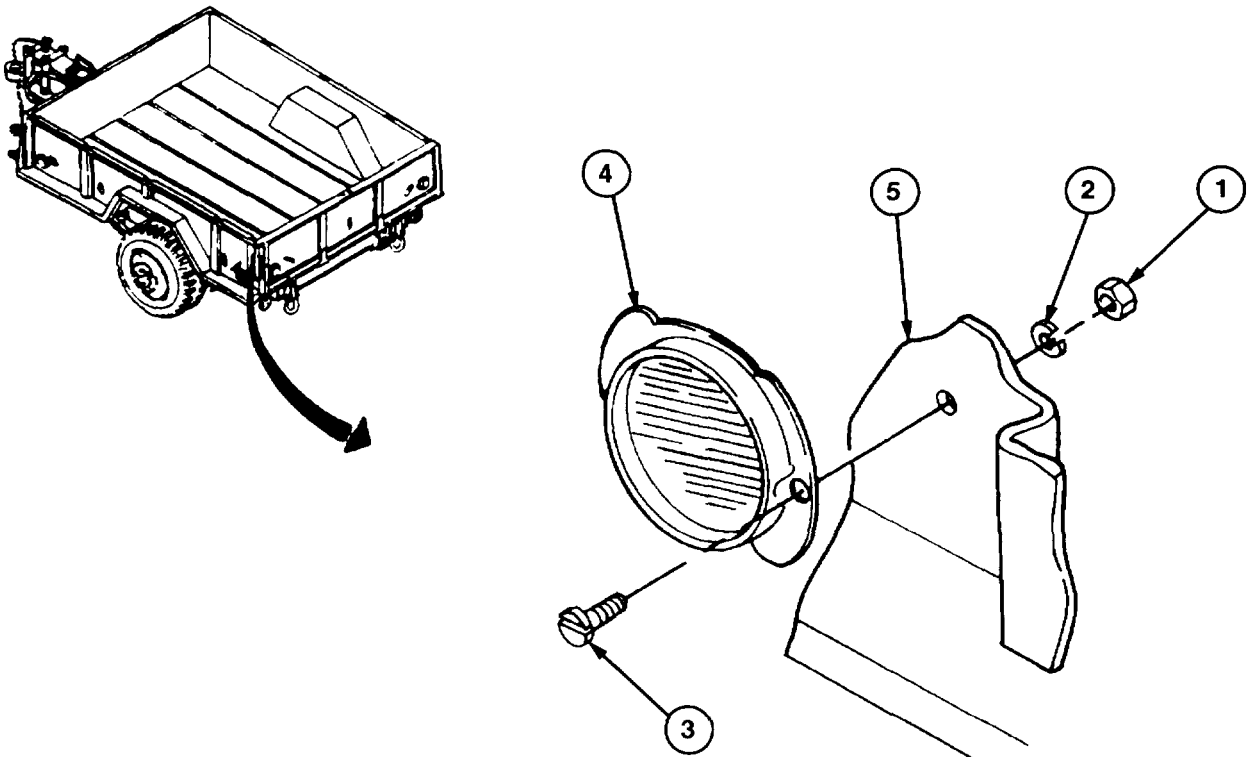
Remove two nuts (1), lockwashers (2), and screws (3) and reflector (4) from cargo body (5). Discard lockwashers.

**b. INSTALLATION**

**NOTE**

Reflector should be installed on cargo body with heads of screws on inside of cargo body.

Install reflector (4) on cargo body (5) with two screws (3), new lockwashers (2), and nuts (1).



**FOLLOW-ON TASKS:**

- None



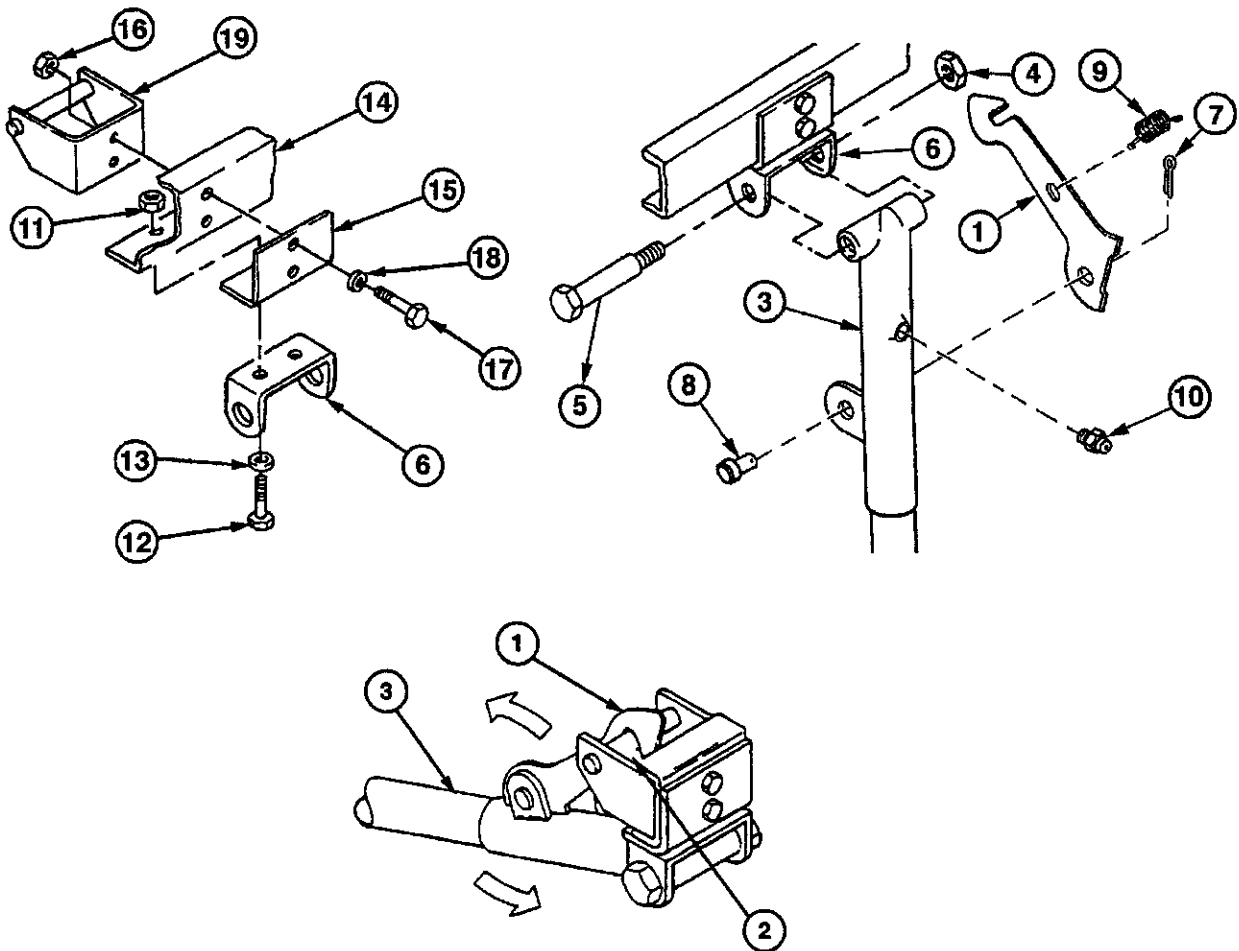


## 4-64. REAR STABILIZER REPLACEMENT (continued).

6. Remove two nuts (11), capscrews (12), lockwashers (13), and bracket (6) from frame (14) and bracket (15). Discard lockwashers.
7. Remove two nuts (16), capscrews (17), lockwashers (18), and brackets (15) and (19) from frame (14). Discard lockwashers.

### b. INSTALLATION

1. Install brackets (15) and (19) on frame (14) with two capscrews (17), new lockwashers (18), and nuts (16).
2. Install bracket (6) on frame (14) and bracket (15) with two capscrews (12), new lockwashers (13), and nuts (11).
3. Install lubrication fitting (10) on rear stabilizer (3).
4. Install spring (9) and latch hook (1) on rear stabilizer (3).
5. Install latch hook (1) on rear stabilizer (3) with straight pin (8) and new cotter pin (7).
6. Install rear stabilizer (3) on bracket (6) with shoulder bolt (5) and new self-locking nut (4).
7. Swing rear stabilizer (3) up until latch hook (1) hooks onto up-latch pin (2).



### FOLLOW-ON TASK:

Lubricate rear stabilizer (Appendix I).

**Section XIV. PAINTING AND IDENTIFICATION MARKING**

<b>Paragraph Number</b>	<b>Paragraph Title</b>	<b>Page Number</b>
4-65	General.....	4-121
4-66	Painting.....	4-121
4-67	Stenciling.....	4-121

**4-65. GENERAL.**

This section gives instruction references for painting and stenciling the M101 and M116 Series trailers.

**4-66. PAINTING.**

- a. Instructions for the preparation of materiel for painting, methods of painting, and materials to be used are contained in TM 43-0139.
- b. Instructions for camouflage painting are contained in FM 20-3 and TB 43-0209.

**4-67. STENCILING.**

Refer to TB 43-0209 for instructions on the application of stencils.

**Section XV. PREPARATION FOR STORAGE AND SHIPMENT**

<b>Paragraph Number</b>	<b>Paragraph Title</b>	<b>Page Number</b>
4-68	General.....	4-122
4-69	Definition of Administrative Storage .....	4-122
4-70	Preparation of Equipment for Administrative Storage .....	4-123
4-71	Care of Equipment in Administrative Storage .....	4-124
Table 4-2	Exercise Schedule.....	4-125
4-72	Procedures for Common Components and Miscellaneous Items .....	4-125
4-73	Removal of Equipment from Administrative Storage .....	4-126
4-74	Preparation of Equipment for Shipment .....	4-126

**4-68. GENERAL.**

- a. This section contains requirements and procedures for the administrative storage of equipment that is issued to and in use by Army activities worldwide.
- b. The requirements specified herein are necessary to maintain equipment in administrative storage in such a way as to achieve maximum readiness condition.
- c. Equipment that is placed in administrative storage should be capable of being readied to perform its mission within a 24-hour period, or as otherwise prescribed by the approving authority. Before equipment is placed in administrative storage, current PMCS procedures should be completed and deficiencies corrected.
- d. Report equipment in administrative storage as prescribed for all reportable equipment (refer to AR 200-1).
- e. Perform inspections, maintenance services, and lubrication as specified herein.
- f. Records and reports to be maintained for equipment in administrative storage are those prescribed by DA Pam 738-750 for equipment in use.
- g. A 10 percent variance is acceptable on time, running hours, or mileage used to determine the required maintenance actions.
- h. Accomplishment of applicable PMCS, as mentioned throughout this section, will be on a semiannual basis.

**4-69. DEFINITION OF ADMINISTRATIVE STORAGE.**

The placement of equipment in administrative storage can be for short periods of time when a shortage of maintenance effort exists. Items should be ready for use within the time factors determined by the directing authority. During the storage period, appropriate maintenance records will be kept.



---

**4-70. PREPARATION OF EQUIPMENT FOR ADMINISTRATIVE STORAGE.**

---

**Storage Site**

- a. Select the best available site for administrative storage. Separate stored equipment from equipment in use. Conspicuously mark the area "Administrative Storage."
- b. Covered space is preferred.
- c. Open sites should be improved hardstand, if available. Unimproved sites should be firm, well drained, and free of excessive vegetation.

**Storage Plan**

- a. Store equipment so as to provide maximum protection from the elements and access for inspection, maintenance, and exercising. Anticipate removal or deployment problems and take suitable precautions.
- b. Take into consideration environmental conditions, such as extreme heat and cold; high humidity; blowing sand, dust, or loose debris; soft ground; mud; heavy snows; or any combination thereof. Take adequate precautions in regard to environmental conditions.
- c. Establish a fire plan and provide for adequate fire-fighting equipment and personnel.

**NOTE**

Steps d and e apply to the M101A2 and M101A3 trailers.

- d. Remove, fold, and stow the canvas cover assembly (para 2-16).
- e. Remove and stow the rack and tailgate assembly (para 2-16).

**Maintenance Services and Inspection**

- a. Prior to storage, perform the next scheduled Unit PMCS.
- b. Inspect and approve the equipment prior to storage. Do not place in storage equipment that is not mission capable.

**Auxiliary Equipment and Basic Issue Items**

- a. Process auxiliary equipment and basic issue items (BII) simultaneously with the major item to which they are assigned.
- b. If possible, store auxiliary equipment and BII with the major item.
- c. If stored apart from the major item, mark auxiliary equipment and BII with tags indicating the major item and its registration or serial number and location, and store in protective-type enclosures. In addition, place a tag or list indicating the location of the removed items in a conspicuous place on the major item.

**Correction of Shortcomings and Deficiencies**

Correct all shortcomings and deficiencies prior to storage, or obtain a deferment from the approving authority.

---

**4-70. PREPARATION OF EQUIPMENT FOR ADMINISTRATIVE STORAGE.**

---

**Lubrication**

Lubricate equipment in accordance with instructions in Appendix I.

**General Cleaning, Painting, and Preservation****CAUTION**

Do not direct water or steam, under pressure, against unsealed electrical systems or any exterior opening. Failure to follow this caution may result in damage to equipment.

- a. Clean dirt, grease, and other contaminants from the equipment, but do not use vapor degreasing.
- b. Remove rust and damaged paint by scraping, wire brushing, sanding, or buffing. Sand to a smooth finish and spot-paint as necessary (refer to TB 43-0209).
- c. After cleaning and drying, immediately coat unpainted metal surfaces with oil or grease, as appropriate (Appendix I). For information on the proper preservation of M101A2 and M101A3 trailers, refer to SB 740-98-1.

---

**4-71. CARE OF EQUIPMENT IN ADMINISTRATIVE STORAGE.**

---

**Maintenance Services**

After equipment has been placed in administrative storage, inspect, service, and exercise as specified in this paragraph.

**Inspection**

Inspection will usually be visual and must consist of at least a walk-around examination of all equipment to detect any deficiencies. Inspect equipment in open storage weekly, and inspect equipment in covered storage monthly. Inspect all equipment immediately after any severe storm or environmental change. The following are examples of things to look for during a visual inspection:

- a. Low or flat tires.
- b. Condition of preservatives, seals, and wraps.
- c. Corrosion or other deterioration.
- d. Missing or damaged parts.
- e. Water in compartments.
- f. Any other readily recognizable shortcomings or deficiencies.

**Repair During Administrative Storage**

Keep equipment in an optimum state of readiness. Accomplish the required services and repairs as quickly as possible. Whenever possible, perform all maintenance on-site.

**4-71. CARE OF EQUIPMENT IN ADMINISTRATIVE STORAGE (continued).**

**Exercising**

Exercise equipment in accordance with Table 4-2 and the following instructions:

- a. Depreserve equipment by removing only that material restricting exercise. Remove blocks and perform all before-operation checks. Couple trailer to towing vehicle and drive for at least 25 miles (40 km). Make several right and left 90-degree turns. Make several hard braking stops without skidding. During exercise when it is convenient and safe, operate all other functional components and perform all during- and after-operation checks.
- b. Scheduled services will include inspection per the "Inspection" paragraph (p. 4-124) and will be conducted in accordance with Table 4-2. Lubricate in accordance with the instructions in Appendix I.
- c. Immediately take action to correct shortcomings and deficiencies noted. Record inspection and exercise results on DA Form 2404. Record and report all maintenance actions on DA Form 2407. After exercising, restore the preservation to the original condition. Replenish lubricants used during exercising and note the amount on DA Form 2408.

*Table 4-2. Exercise Schedule*

<b>Weeks</b>	<b>2</b>	<b>4</b>	<b>6</b>	<b>8</b>	<b>10</b>	<b>12</b>	<b>14</b>	<b>16</b>	<b>18</b>	<b>20</b>	<b>22</b>	<b>24</b>
PMCS						X						X
Scheduled Services		X		X		X		X		X		
Major Exercises												X

**Rotation**

Rotate items in accordance with any rotational plan that will keep the equipment in operational condition and reduce the maintenance effort.

**4-72. PROCEDURES FOR COMMON COMPONENTS AND MISCELLANEOUS ITEMS.**

**Tires**

Visually inspect tires during each walk-around inspection. This inspection includes checking tires with a tire gage. Inflate, repair, or replace as necessary those tires found to be low, damaged, or excessively worn. Mark inflated and repaired tires with a crayon for checking at the next inspection.

**Seals**

Seals may develop leaks during storage or shortly thereafter. If leaking persists, refer to the applicable maintenance section in this manual for corrective maintenance procedures.

---

**4-73. REMOVAL OF EQUIPMENT FROM ADMINISTRATIVE STORAGE.**

---

**Activation**

Restore equipment to normal operating condition in accordance with the instructions contained in Chapter 4, Section II.

**Servicing**

Resume the maintenance service schedule in effect at the commencement of storage, or service the equipment before the scheduled dates in order to produce a staggered workload.

---

**4-74. PREPARATION OF EQUIPMENT FOR SHIPMENT.**

---

- a. Refer to FM 55-21, TM 55-601, and TM 743-200-1 for additional instructions on processing, storage, and shipment of materiel.
- b. Trailers shipped on flatcars require wheel blocking in accordance with the Association of American Railroads' rules governing the loading of commodities on "open top" cars.
- c. Trailers that have been removed from storage for shipment do not have to be reprocessed if they will reach their destination within the administrative storage period. Reprocess only if inspection reveals any corrosion or if in-transit weather conditions make it necessary.
- d. When a trailer is received and has already been processed for domestic shipment, as indicated on DD Form 1397, the trailer does not have to be reprocessed for storage unless corrosion and deterioration are found during the inspection upon receipt. List, on SF Form 364, all discrepancies found because of poor preservation, packaging, packing, marking, handling, loading, storage, or excessive preservation. Repairs that cannot be handled by the receiving unit must have tags attached listing needed repairs. A report of these conditions will be submitted by the Unit commander for action by an ordnance maintenance Unit.

**CHAPTER 5  
DIRECT SUPPORT AND GENERAL SUPPORT MAINTENANCE**

**Section I. AXLE MAINTENANCE**

---

**5-1. AXLE REPLACEMENT.**

---

*This Task Covers:*

- a. Removal b. Installation
- 

*Initial Setup:*

**Tools/Test Equipment:**

- General mechanic's tool kit (Item 1, Appendix B)
- Field maintenance tool set (Item 5, Appendix B)

**Equipment Conditions:**

- Shock absorbers removed (para 4-54).
- Hydraulic brake lines removed from axle (para 4-39).
- Service brakes removed (para 4-34).

**Materials/Parts:**

- Self-locking nut (8), MS21044-N8

**Personnel Required:** Two

---

**WARNING**

**Use extreme caution when handling heavy parts. Lifting device is required when parts weigh over 50 pounds (23 kg) for a single-person lift, over 100 pounds (45 kg) for a two-person lift, and over 150 pounds (68 kg) for a three-person or more lift. Keep clear of heavy parts supported only by lifting device. Failure to follow this warning may result in serious injury or death to personnel.**

**NOTE**

Replacement of axle is the same for all models. This procedure shows replacement of the M116A2 axle.

**a. REMOVAL**

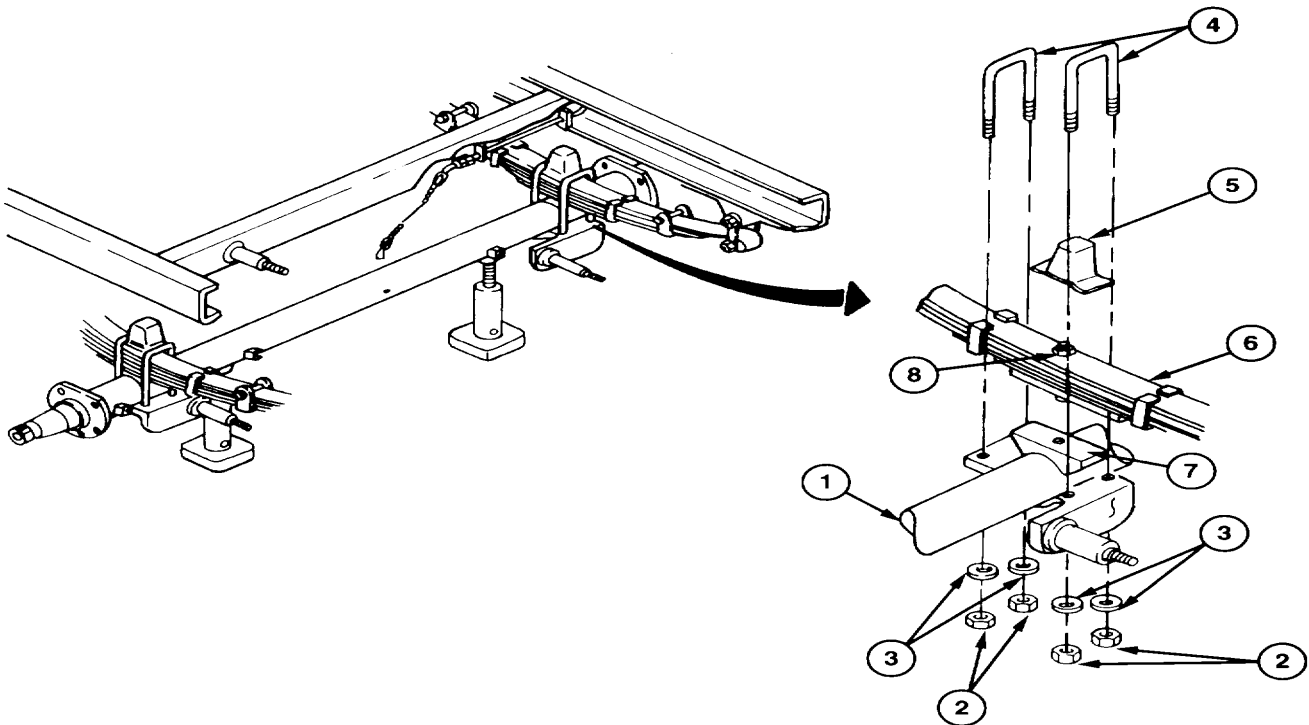
1. Block and support frame securely, front and rear.

**5-1. AXLE REPLACEMENT (continued).**

2. Place floor jack under midpoint of axle (1) to provide a balanced support.
3. At each end of axle (1), remove four self-locking nuts (2) and washers (3), two U-bolts (4), and bumper (5) from spring assembly (6) and spring plate (7). Discard self-locking nuts.
4. Remove axle (1) from under trailer and from floor jack.

**b. INSTALLATION**

1. Place midpoint of axle (1) on floor jack and position axle (1) under trailer.



2. Raise axle (1) until it contacts underside of spring assembly (6). At each end of axle (1), engage spring assembly center bolt head (8) with hole in pad on bumper (5).
3. Install bumper (5) on each spring assembly (6).
4. At each end of axle (1), install two U-bolts (4) into grooves of bumper (5) and through holes in spring plate (7).
5. At each end of axle (1), install four washers (3) and new self-locking nuts (2) on two U-bolts (4).
6. Remove floor jack from under axle (1).

**FOLLOW-ON TASKS:**

- Install service brakes (para 4-34).
- Install hydraulic brake lines on axle (para 4-39).
- Install shock absorbers (para 4-54).

**Section II. BRAKEDRUM AND TIRE MAINTENANCE**

<b>Paragraph Number</b>	<b>Paragraph Title</b>	<b>Page Number</b>
5-2	General.....	5-3
5-3	Brakedrum Repair .....	5-3
5-4	Tire Repair.....	5-5

**5-2. GENERAL.**

The section describes and illustrates repair procedures for the brakedrum and tire.

**5-3. BRAKEDRUM REPAIR.**

*This Task Covers:*

- |               |           |
|---------------|-----------|
| a. Inspection | b. Repair |
|---------------|-----------|

*Initial Setup:*

**Tools/Test Equipment:**

- Field maintenance tool set (Item 5, Appendix B)

**Materials/Parts:**

- Rag (Item 13, Appendix F)
- Solvent, drycleaning (Item 15, Appendix F)

**a. INSPECTION**

**WARNING**

- **DO NOT** handle brakeshoes, brakedrums, or other brake components unless area has been properly cleaned. Asbestos dust, which can be dangerous if you touch it or breathe it, may be on these components. Wear an approved filter mask and gloves. **NEVER** use compressed air or a dry brush to clean brake components. Dust may be removed using an industrial-type vacuum cleaner. Clean dust or mud away from brake components with water and a wet, soft brush or cloth. Failure to follow this warning may result in serious illness or death to personnel.
- Drycleaning solvent P-D-680 is toxic and flammable. Always wear protective goggles and gloves, and use only in a well-ventilated area. Avoid contact with skin, eyes, and clothes, and **DO NOT** breathe vapors. **DO NOT** use near open flame or excessive heat.

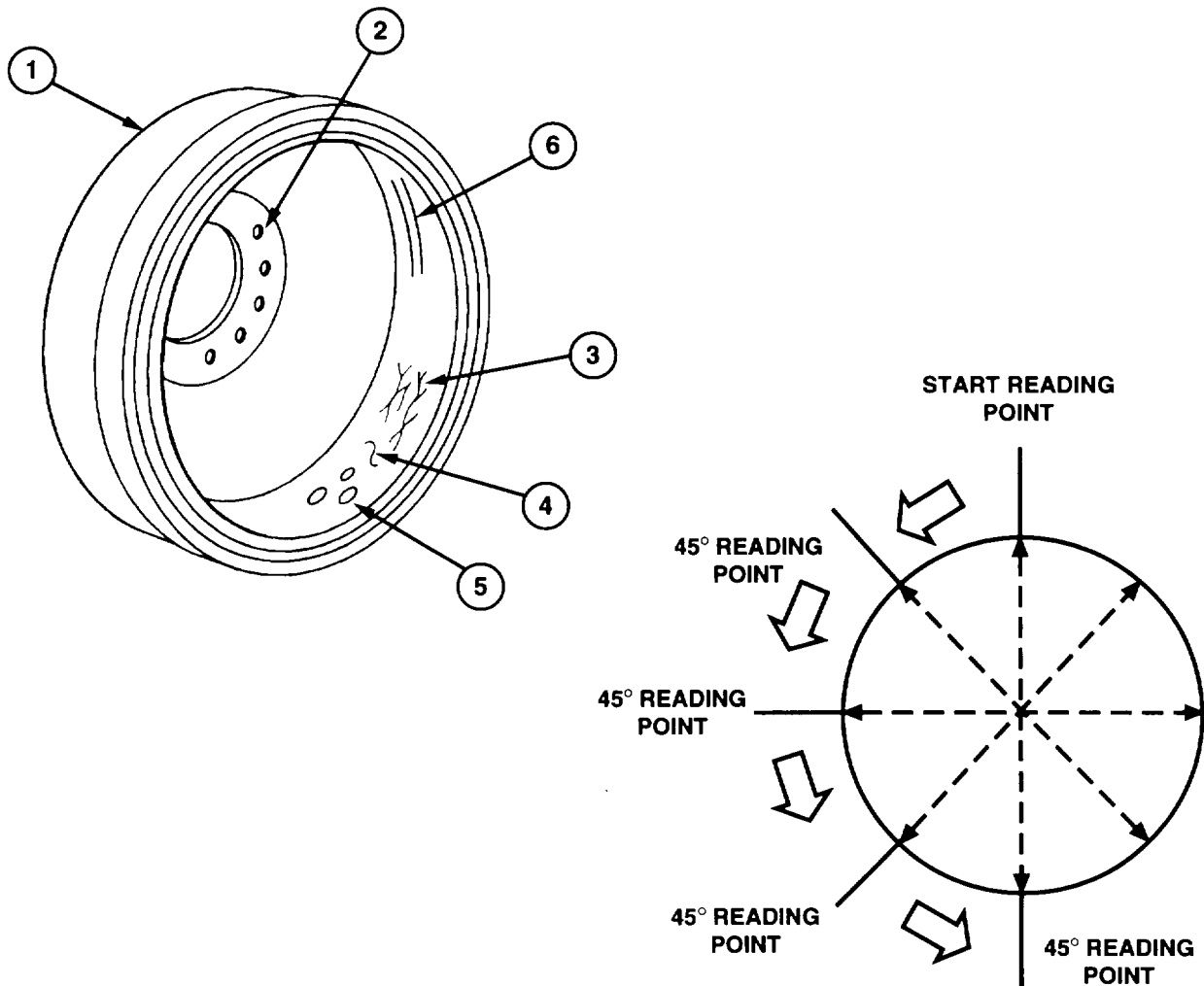
**5-3. BRAKEDRUM REPAIR (continued).**

1. Clean brakedrum (1) with drycleaning solvent and allow to dry.
2. Inspect stud holes (2) for cracks (3). Discard brakedrum (1) if stud holes are cracked.

**WARNING**

DO NOT use a brakedrum that exceeds maximum wear specifications. Failure to follow this warning may result in brake failure and serious injury or death to personnel.

3. Measure inside diameter of brakedrum (1). Discard and replace brakedrum (1) if inside diameter exceeds 12.065 inches (30.645 cm).
4. Inspect braking surface (4) for cracks (3), hot spots (5), and scoring (6). Reface braking surface if damaged (subpara b).
5. Inspect braking surface (4) for out-of-round at 45-degree intervals. Out-of-round should not exceed 0.015 inch (0.381 mm). If runout exceeds 0.015 inch (0.381 mm), reface braking surface (subpara b).





---

**5-3. BRAKEDRUM REPAIR (continued).**

---

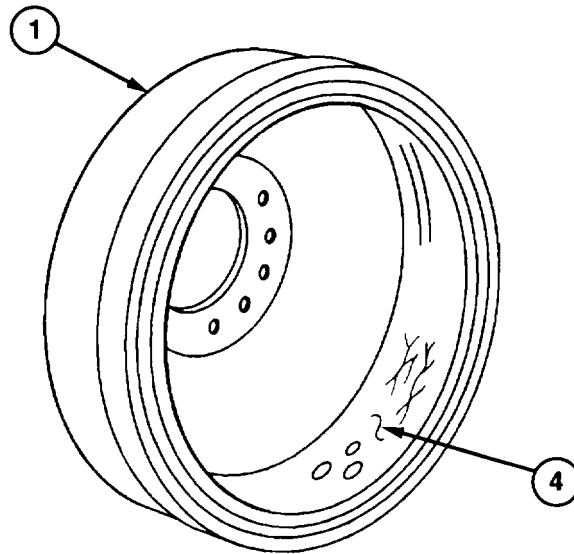
**b. REPAIR**

1. Reface braking surface (4) with brakedrum lathe, removing a maximum of 0.01 inch (0.25 mm) per cut.

**WARNING**

**DO NOT use a brakedrum that exceeds maximum wear specifications. Failure to follow this warning may result in brake failure and serious injury or death to personnel.**

2. Discard and replace brakedrum (1) if inside diameter exceeds 12.065 inches (30.645 cm) after refacing.

**FOLLOW-ON TASKS:**

- None

---

**5-4. TIRE REPAIR.**

---

Refer to TM 9-2610-200-14 for instructions on tire repair.

**Section III. FRAME ASSEMBLY MAINTENANCE**

---

**5-5. FRAME ASSEMBLY REPAIR.**

---

Refer to TB 9-2300-247-40 for instructions on frame assembly repair.

**Section IV. ACCESSORY ITEMS MAINTENANCE**

---

**5-6. CANVAS COVER ASSEMBLY REPAIR (M101A2 AND M101A3).**

---

Refer to FM 10-16 for instructions on canvas cover assembly repair.

**5-7/(5-8 blank)**

**APPENDIX A  
REFERENCES**

<b>Paragraph Number</b>	<b>Paragraph Title</b>	<b>Page Number</b>
A-1	General.....	A-1
A-2	Forms .....	A-1
A-3	Field Manuals .....	A-1
A-4	Technical Manuals .....	A-2
A-5	Pamphlets and Bulletins .....	A-2
A-6	Other Publications .....	A-3

**A-1. GENERAL.**

This appendix lists all forms, manuals, pamphlets, bulletins, and other publications that are referenced in this manual and/or apply to the operation and maintenance of the M101 and M116 Series trailers. DA Pam 25-30, *Consolidated Index of Army Publications and Blank Forms*, should be consulted frequently for the latest changes or revisions and for new publications relevant to material covered in this technical manual.

**A-2. FORMS.**

Refer to DA Pam 738-750, *The Army Maintenance Management System (TAMMS)*, for instructions on the use of maintenance forms.

Recommended Changes to Publications and Blank Forms.....	DA Form 2028
Recommended Changes to Equipment Technical Publications .....	DA Form 2028-2
Organization Control Record for Equipment .....	DA Form 2401
Equipment Inspection and Maintenance Worksheet.....	DA Form 2404
Maintenance Request .....	DA Form 2407
Equipment Log Assembly (Records).....	DA Form 2408
Equipment Control Record.....	DA Form 2408-9
Serial/Registration Number Record.....	DA Form 3328-1
Preventive Maintenance Schedule and Record .....	DD Form 314
Processing and Deprocessing Record for Shipment, Storage and Issue of Vehicles and Spare Engines .....	DD Form 1397
Report of Discrepancy (ROD) .....	SF Form 364
Product Quality Deficiency Report.....	SF Form 368

**A-3. FIELD MANUALS.**

NBC Contamination Avoidance.....	FM 3-3
NBC Protection.....	FM 3-4
NBC Decontamination.....	FM 3-5
Operation and Maintenance of Ordnance Materiel in Cold Weather (O Degrees F to Minus 65 Degrees F) .....	FM 9-207

**A-3. FIELD MANUALS (continued).**

General Fabric Repair .....	FM 10-16
Camouflage .....	FM 20-3
First Aid for Soldiers .....	FM 21-11
Manual for the Wheeled Vehicle Driver .....	FM 21-305
Basic Cold Weather Manual .....	FM 31-70
Northern Operations .....	FM 31-71
Railway Operating and Safety Rules .....	FM 55-21
Army Motor Transport Units and Operations .....	FM 55-30
Desert Operations (How To Fight) .....	FM 90-3
Mountain Operations .....	FM 90-6

**A-4. TECHNICAL MANUALS.**

Inspection, Care and Maintenance of Antifriction Bearings .....	TM 9-214
Operator's Manual for Welding Theory and Application .....	TM 9-237
Deepwater Fording of Ordnance Materiel .....	TM 9-238
Materials Used for Cleaning, Preserving, Abrading and Cementing Ordnance Materiel and Related Materials, Including Chemicals .....	TM 9-247
Operator's, Unit, Direct Support and General Support Maintenance Manual for Care, Maintenance Repair and Inspection of Pneumatic Tires and Inner Tubes .....	TM 9-2610-200-14
Painting Instructions for Army Materiel .....	TM 43-0139
Railcar Loading Procedures .....	TM 55-601
Storage and Materials Handling .....	TM 743-200-1
Procedures for Destruction of Tank-Automotive Equipment to Prevent Enemy Use .....	TM 750-244-6

**A-5. PAMPHLETS AND BULLETINS.**

Consolidated Index of Army Publications and Blank Forms .....	DA Pam 25-30
Using Unit Supply System (Manual Procedures) .....	DA Pam 710-2-1
The Army Maintenance Management System (TAMMS) .....	DA Pam 738-750
Storage and Serviceability Standard: Tracked Vehicles, Wheeled Vehicles, and Component Parts .....	SB 740-98-1
Description, Use, Bonding Techniques, and Properties of Adhesive .....	TB ORD 1032
Tactical Wheeled Vehicles: Repair of Frames .....	TB 9-2300-247-40
Equipment Improvement Report and Maintenance Digest (U.S. Army Tank-automotive and Armaments Command). Tank and Automotive Equipment .....	TB 43-0001-39 Series
Color, Marking, and Camouflage Painting of Military Vehicles, Construction Equipment and Materials Handling Equipment .....	TB 43-0209
Maintenance in the Desert .....	TB 43-0239

---

**A-6. OTHER PUBLICATIONS.**

---

Environmental Protection and Enhancement.....	AR 200-1
Army Logistics Readiness and Sustainability.....	AR 700-138
Reporting of Product Quality Deficiencies Across Component Lines .	AR 702-7
Army Medical Department Expendable/Durable Items .....	CTA 8-100
Expendable/Durable Items (Except Medical, Class V, Repair Parts and Heraldic Items).....	CTA 50-970
Abbreviations for Use on Drawings, Specifications, Standards, and in Technical Documents .....	MIL-STD-12

**A-3/(A-4 blank)**

**APPENDIX B  
MAINTENANCE ALLOCATION CHART**

**Section I. INTRODUCTION**

Paragraph Number	Paragraph Title	Page Number
B-1	General.....	B-1
B-2	Maintenance Functions .....	B-1
B-3	Explanation of Columns in Section II, Maintenance Allocation Chart for M101 and M116 Series Trailers.....	B-2
B-4	Explanation of Columns in Section III, Tool and Test Equipment Requirements.....	B-3
B-5	Explanation of Columns in Section IV, Remarks.....	B-3

---

**B-1. GENERAL.**

---

Appendix B consists of four sections:

- a. Section I provides a general explanation of all maintenance and repair functions authorized at the various maintenance levels.
- b. Section II, the maintenance allocation chart (MAC), designates overall authority and responsibility for the performance of maintenance functions on the identified end item or component. The application of the maintenance functions to the end item or component will be consistent with the capacities and capabilities of the designated maintenance levels.
- c. Section III lists the tools and test equipment (both special tools and common tool sets) required for each maintenance function as referenced from Section II
- d. Section IV contains supplemental instructions and explanatory notes for some maintenance functions.

---

**B-2. MAINTENANCE FUNCTIONS.**

---

Maintenance functions are limited to and defined as follows:

- a. **Inspect.** To determine the serviceability of an item by comparing its physical, mechanical, and/or electrical characteristics with established standards through examination (e.g., by sight, sound, or feel).
- b. **Test.** To verify serviceability by measuring the mechanical, pneumatic, hydraulic, or electrical characteristics of an item and comparing those characteristics with prescribed standards.
- c. **Service.** To keep an item in proper operating condition by periodically cleaning (including decontaminating, when required), preserving, draining, painting, or replenishing fuel, lubricants, chemical fluids, or gases.
- d. **Adjust.** To maintain or regulate, within prescribed limits, by bringing into proper or exact position or by setting the operating characteristics to specified parameters.
- e. **Align.** To adjust specified variable elements of an item to bring about optimum or desired performance.

---

**B-2. MAINTENANCE FUNCTIONS (continued).**


---

- f. **Calibrate.** To determine the accuracy of and cause corrections or adjustments to be made on instruments or test, measuring, and diagnostic equipment (TMDE) used in precision measurement. Calibration consists of comparisons of two instruments, one of which is a certified standard of known accuracy, to detect and adjust any discrepancy in the accuracy of the instrument being compared.
- g. **Remove/install.** To remove and install the same item when required to perform service or other maintenance functions "Install" may be the act of emplacing, seating, or fixing into position a spare, repair part, or module (component or assembly) in a manner to allow the proper functioning of an equipment or system.
- h. **Replace.** To remove an unserviceable item and Install a serviceable counterpart in its place. "Replace" is authorized by the MAC and is shown as the third position of the source, maintenance, and recoverability (SMR) code.
- i. **Repair.** To apply maintenance services--including fault location/troubleshooting, removal/installation, and disassembly/assembly procedures--and maintenance actions to identify troubles and restore serviceability to an item by correcting any specific damage. fault, malfunction, or failure in a part, subassembly, module (component or assembly), end Item. or system.
- j. **Overhaul.** To perform that maintenance effort (service/action) required to restore an item to a completely serviceable/operational condition as required by maintenance standards in an appropriate technical publication (e.g., depot maintenance work requirement). Overhaul is normally the highest degree of maintenance performed by the Army. Overhaul does not normally return an item to like-new condition.
- k. **Rebuild.** To perform those services/actions necessary for the restoration of unserviceable equipment to a like-new condition In accordance with original manufacturing standards. Rebuild is the highest degree of materiel maintenance applied to Army equipment. The rebuild operation includes the act of returning to zero those age measurements (hours,/miles, etc.) considered in classifying Army equipment/components.

---

**B-3. EXPLANATION OF COLUMNS IN SECTION II, MAINTENANCE ALLOCATION CHART FOR M101 AND M116 SERIES TRAILERS.**


---

- a. **(1) Group Number.** Column 1 lists functional group code numbers, whose purpose is to identify maintenance significant components, assemblies, subassemblies, and modules with the next higher assembly. The end item group number is "00."
- b. **(2) Component/Assembly.** Column 2 contains the names of components, assemblies, subassemblies, and modules for which maintenance is authorized.
- c. **(3) Maintenance Function.** Column 3 lists the functions to be performed on the item listed in Column 2. (For a detailed explanation of these functions, refer to para B-2.)
- d. **(4) Maintenance Level.** Column 4 specifies, by the listing of a work-time figure in the appropriate subcolumn(s), the level of maintenance authorized to perform the function listed in Column 3. This figure represents the active time required to perform that maintenance function at the indicated level of maintenance. If the number or complexity of the tasks within the listed maintenance function varies at different maintenance levels, appropriate work-time figures will be shown for each level. The work-time figure represents the average time required to restore an item (assembly, subassembly, component, module, end item, or system) to a serviceable condition under typical field operating conditions. This time includes preparation time (including



---

**B-3. EXPLANATION OF COLUMNS IN SECTION II, MAINTENANCE ALLOCATION CHART FOR M101 AND M116 SERIES TRAILERS (continued).**

---

any necessary disassembly/assembly time), troubleshooting/fault location time, and quality assurance/ quality control time in addition to the time required to perform the specific tasks identified for the maintenance functions authorized in the MAC. The symbol designations for the various maintenance levels are as follows:

- C..... Operator/Crew
- O..... Unit
- F..... Direct Support
- H..... General Support
- D..... Depot

- e. **(5) Tools and Equipment Reference Code.** Column 5 specifies, by code, those common tool sets (not individual tools), common TMDE, special tools, special TMDE, and special support equipment required to perform the designated maintenance function. Codes are keyed to tools and test equipment listed in Section III.
- f. **(6) Remarks.** When applicable, this column contains a letter code, in alphabetical order, which is keyed to remarks contained in Section IV. If there is nothing in the Remarks column, there is no Section IV.

---

**B-4. EXPLANATION OF COLUMNS IN SECTION III, TOOL AND TEST EQUIPMENT REQUIREMENTS.**

---

- a. **Column 1, Tool or Test Equipment Reference Code.** This code correlates with the code used in Section II, Column 5.
- b. **Column 2, Maintenance Level.** The symbol designation shown indicates the lowest level of maintenance authorized to use the tool or test equipment.
- c. **Column 3, Nomenclature.** This is the name or identification of the tool or test equipment.
- d. **Column 4, National Stock Number.** This is the national stock number of the tool or test equipment.
- e. **Column 5, Tool Number.** This is the manufacturer's part number.

---

**B-5. EXPLANATION OF COLUMNS IN SECTION IV, REMARKS.**

---

- a. **Column 1, Remarks Code.** This column contains the code letter recorded in Column 6 of Section II, the MAC.
- b. **Column 2, Remarks.** This column provides information pertinent to the maintenance function being performed as indicated in Section II, the MAC.

Section II. MAINTENANCE ALLOCATION CHART  
FOR M101 AND M116 SERIES TRAILERS

(1) Group Number	(2) Component/Assembly	(3) Maintenance Function	(4) Maintenance Level					(5) Tools and Test Equipment Ref. Code	(6) Remarks
			C	O	F	H	D		
<b>06</b>	<b>ELECTRICAL SYSTEM</b>								
(0609	<i>Lights</i>	Replace		0.5				1	A
		Repair		0.5				1	
	Lamps	Replace		0.5				1	
(0613	<i>Hull or Chassis Wiring Harness</i>								
	Wiring Harness, Branched	Replace		0.5				1	
<b>11</b>	Cable, Intervehicular	Replace		0.3				1	
1100	<b>REAR AXLE</b>								
	<i>Rear Axle Assembly</i>	Inspect		1.0					
<b>12</b>		Replace			5.5			1, 5	
1201	<b>BRAKES</b>								
	<i>Handbrakes</i>								
	Handbrake Levers and Linkage	Adjust		0.1				1, 2	
1202		Replace		2.0				1	
	<i>Service Brakes</i>								
	Brake Assemblies	Adjust		0.5				1,2	
1204		Replace		2.0				1, 2	
	<i>Hydraulic Brake System</i>	Repair			1.5			5	
	Cylinder Assembly, Wheel	Replace		1.5				1, 2	
	Actuator Assembly, Brake	Replace		2.0				1, 2	
		Repair		2.0				1, 2	
	Cylinder Assembly, Master	Service		0.1					
		Replace		1.0				1, 2	
	Brake Lines, Hydraulic	Inspect		0.1					
		Replace		1.0				1, 2	

**MAINTENANCE ALLOCATION CHART FOR  
M101 AND M116 SERIES TRAILERS (continued)**

(1) Group Number	(2) Component/Assembly	(3) Maintenance Function	(4) Maintenance Level					(5) Tools and Test Equipment Ref. Code	(6) Remarks
			C	O	F	H	D		
<b>13</b>	<b>WHEEL AND TRACKS</b>								
1311	<i>Wheel Assembly</i>								
	Brakedrum	Inspect Replace Repair		0.5 1.0	2.0			1, 2 5	
	Hub Bearings, Wheel	Service Adjust Replace		1.0 0.2 1.0				1, 2 1, 2 1, 2	
	Wheel	Inspect Replace	0.1	2.0				1, 2	
1313	<i>Tires, Tubes, Tire Chains</i>								
	Tire	Inspect Replace Repair	0.1	1.0	2.0			1, 2 1, 5	B
	Tube, Inner	Replace Repair		1.0 1.0				1, 2 1, 2	B
<b>15</b>	<b>FRAME, TOWING ATTACHMENTS, DRAWBARS, AND ARTICULATION SYSTEMS</b>								
1501	<i>Frame Assembly</i>	Repair		1.0	4.0			1, 2, 5, 6, 7	C
1503	<i>Pintles and Towing Attachments</i>								
	Drawbar	Replace Repair		1.5	2.0			1, 2 1, 2, 5, 6, 7	
	Bracket Assembly, Drawbar	Replace		3.0				1, 2	
	Chains, Safety	Replace		0.5				1, 2	

**MAINTENANCE ALLOCATION CHART FOR  
M101 AND M116 SERIES TRAILERS (continued)**

(1) Group Number	(2) Component/Assembly	(3) Maintenance Function	(4) Maintenance Level					(5) Tools and Test Equipment Ref. Code	(6) Remarks
			C	O	F	H	D		
1507	<i>Landing Gear, Leveling Jacks</i>								
	Leg, Support, Front, (Adjustable)	Replace		2.0				1, 2	
		Service		0.5				1, 2	
<b>16</b>	<b>SPRINGS AND SHOCK ABSORBERS</b>								
1601	<i>Springs</i>	Replace		2.0				1, 2	
1604	<i>Shock Absorber Equipment</i>								
	Absorber, Shock	Replace		1.0				1, 2	
<b>18</b>	<b>BODY, CAB, HOOD, AND HULL</b>								
1810	<i>Cargo Body</i>	Replace		4.0				1, 2	
<b>22</b>	<b>BODY, CHASSIS, AND HULL ACCESSORY ITEMS</b>								
2201	<i>Canvas, Rubber, or Plastic Items</i>								
	Cover Assembly, Canvas	Replace Repair		0.5	1.0			1, 5	
2202	<i>Accessory Items</i>								
	Reflector	Replace		0.5				1	
2210	<i>Data Plates and Instruction Holders</i>								
	Plate, Identification	Replace		1.0				1, 2, 3, 4	
<b>33</b>	<b>SPECIAL PURPOSE KIT</b>								
3307	<i>Special Purpose Kit</i>								
	Stabilizer Kit, Rear	Replace Repair		1.0 0.5				1 1	

**Section III. TOOL AND TEST EQUIPMENT REQUIREMENTS**

(1) TOOL OR TEST EQUIPMENT REF CODE	(2) MAINTENANCE LEVEL	(3) NOMENCLATURE	(4) NATIONAL STOCK NUMBER	(5) TOOL NUMBER
1	0	Tool Kit, General Mechanic's: Automotive	5180-00-177-7033	
2	0	Shop Equipment, Automotive Maintenance and Repair: Organizational Maintenance, Common No. 1, Less Power	4910-00-754-0654	
3	0	Die Set, Metal Stamping, Hand: With 1/4-In. Numbers	5110-00-289-0003	
4	0	Die Set, Metal Stamping, Hand: With 1/4-In. Upper Case Letters, Ampersand, and Period	5110-00-289-0007	
5	F	Shop Equipment, Automotive Maintenance and Repair: Field Maintenance, Basic, Less Power	4910-00-754-0705	
6	F	Shop Equipment, Welding, Field Maintenance	3470-00-357-7268	
7	F	Tool Kit, Welder's	5810-00-754-0661	

**Section IV. REMARKS**

(1) Remarks Code	(2) Remarks
A	Stoplight-taillight and composite stoplight-taillight repair is limited to lens, preformed packing, and lamp or LED replacement.
B	Refer to TM 9-2610-200-14 for information on tire and tube repair.
C	Refer to TB 9-2300-247-40 for information on frame repair.

**B-7/(B-8 blank)**



**APPENDIX C**  
**COMPONENTS OF END ITEM AND BASIC ISSUE ITEMS LISTS**

The M101 and M1 16 Series trailers currently do not have any assigned components of end item or basic issue items.

**C-1/(C-2 blank)**





**APPENDIX D  
ADDITIONAL AUTHORIZATION LIST**

**Section I. INTRODUCTION**

Paragraph Number	Paragraph Title	Page Number
D-1	Scope .....	D-1
D-2	General .....	D-1
D-3	Explanation of Columns .....	D-1

**D-1. SCOPE**

This appendix lists additional items you are authorized for support of the M101 and M116 Series trailers.

**D-2. GENERAL.**

This list identifies items that do not have to accompany the trailers and do not have to be turned in with them. These items are all authorized to you by CTA or MTOE.

**D-3. EXPLANATION OF COLUMNS.**

- a. In Section II (Additional Authorization List), the national stock number, description, Commercial and Government Entity Code (CAGEC) and part number, unit of measure (U/M), and quantity recommended (Qty. Recm.) are provided for each item to help you identify and request the items you need to support this equipment.
- b. The items are listed in alphabetical sequence by item name under the type of document (CTA or MTOE) that authorizes the item(s) to you.
- c. If the item required differs for different models of this equipment, see the "Used-On Code" entries for the applicable model. These codes are as follows:

Used-On Code	Model
263	M101A2
TC1	M101A3
258	M116A2
SPR	M116A2E1
CT1	M116A3

Section II. ADDITIONAL AUTHORIZATION LIST (AAL)

(1) NATIONAL STOCK NUMBER	(2) Description CAGEC and Part Number	USABLE ON CODE	(3) U/M	(4) QTY AUTH
<b>CTA Authorized Items</b>				
2540-00-133-3492	Bow and Tarpaulin Accessory Kit, Vehicle Body: Includes 5 Bows and Tarpaulin Cover Assembly, Green (19207)11674804	263, CT1	EA	1
	Bow and Tarpaulin Accessory Kit, Vehicle Body: Includes 5 Bows and Tarpaulin Cover Assembly, Tan (19207)11674804-1	263, CT1	EA	1
<b>MTOE Authorized Items</b>				
5120-00-243-2419	Bar, Socket Wrench Handle: 3/4-Inch Diameter, 30 Inches Long (19207) 6196147		EA	1
5120-00-293-2452	Wrench, Double Socket, Hexagon: 1 1/2 and 1 1/16-Inch Openings, 10 Inches Long (19207) 7083293	263	EA	1
5120-01-156-7296	Wrench, Wheel Lug: CUCV (11862)14009303	263	EA	1
<b>D-2</b>				

**APPENDIX E  
REPAIR PARTS AND SPECIAL TOOLS LIST**

**Section I. INTRODUCTION**

Paragraph Number	Paragraph Title	Page Number
E-1	Scope .....	E-1
E-2	General.....	E-1
E-3	Explanation of Columns (Sections II and III) .....	E-2
E-4	Explanation of Columns (Section IV) .....	E-6
E-5	Special Information.....	E-7
E-6	How To Locate Repair Parts .....	E-7
E-7	Abbreviations .....	E-7

**E-1. SCOPE.**

This repair parts and special tools list (RPSTL) lists and authorizes spares and repair parts; special tools; special test, measurement, and diagnostic equipment (TMDE); and other special support equipment required for the performance of Unit, Direct Support, and General Support maintenance of the M101 and M116 Series trailers. It authorizes the requisitioning, issue, and disposition of spares, repair parts, and special tools as indicated by the source, maintenance, and recoverability (SMR) code.

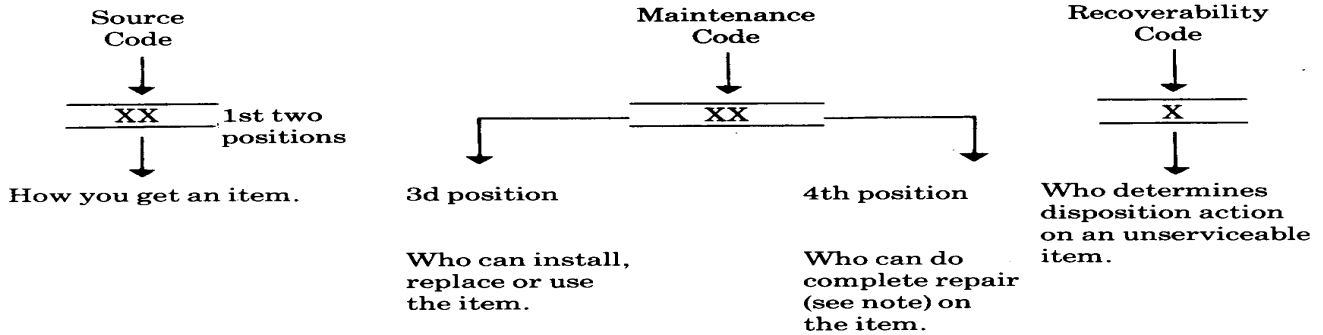
**E-2. GENERAL.**

In addition to Section I, this RPSTL is divided into the following sections:

- a. **Section II. Repair Parts List.** A list of spares and repair parts authorized by this RPSTL for use in the performance of maintenance. The list also includes parts that must be removed for replacement of the authorized parts. Parts lists are composed of functional groups in ascending alphanumeric sequence, with the parts in each group listed in ascending figure and item number sequence. Bulk materials are listed in item name sequence. Repair parts kits are listed separately in their own functional group within Section II. Repair parts for repairable special tools are also listed in this section. Items listed are shown on the associated illustration(s)/figure(s).
- b. **Section III. Special Tools List.** A list of special tools, special TMDE, and other special support equipment authorized by this RPSTL for the performance of maintenance.
- c. **Section IV. Cross Reference Indexes.** A list, in national item identification number (NIIN) sequence, of all national stock numbered items appearing in the listing, followed by a list in alphanumeric sequence of all part numbers appearing in the listings. National stock numbers (NSNs) and part numbers are cross-referenced to each illustration/figure and item number appearance. The figure and item number index lists each figure and item number in alphanumeric sequence and cross-references the NSN, commercial and government entity code (CAGEC), and part number.

**E-3. EXPLANATION OF COLUMNS (SECTIONS II AND III).**

- a. **ITEM NO. [Column (1)].** Indicates the number used to identify items called out in the illustration.
- b. **SMR CODE [Column (2)].** The SMR code is a five-position code containing supply/requisitioning information, maintenance category authorization criteria, and disposition instruction, as shown in the following breakout:



\* *Complete Repair* Maintenance capacity, capability, and authority to perform all corrective maintenance tasks of the "Repair" function in a use/user environment In order to restore serviceability to a failed Item.

- (1) **Source Code.** The source code tells you how to get an item needed for maintenance, repair, or overhaul of an end item/equipment. Explanations of source codes follow:

<u>Code</u>	<u>Application/Explanation</u>
PA PB PC PD PE PF PG	Stocked items; use the applicable NSN to request/requisition items with these source codes. They are authorized to the category indicated by the code entered in the third position of the SMR code.  <i>"Items coded PC are subject to deterioration."</i>
KD KF KB	Items with these codes are not to be requested/requisitioned individually. They are part of a kit that is authorized to the maintenance category indicated in the third position of the SMR code. The complete kit must be requisitioned and applied.
MO—Made at org/ AVUM category MF—Made at DS/ AVUM category MH—Made at GS category ML—Made at Specialized Repair Activity (SRA) MD—Made at Depot	Items with these codes are not to be requested/requisitioned individually. They must be made from bulk material that is identified by the part number in the DESCRIPTION AND USABLE-ON CODE (UOC) column and listed in the bulk material group of the repair parts list in this RPSTL. If the item is authorized to you by the third-position code of the SMR code but the source code indicates it is made at a higher level, order the item from the higher level of maintenance.

**E-3. EXPLANATION OF COLUMNS (SECTIONS II AND III) (continued).**

AO —Assembled by  
org/AVUM  
category  
AF —Assembled by  
DS/AVUM  
category  
AH —Assembled by  
GS category  
..  
AD —Assembled by  
Depot

Items with these codes are not to be requested/requisitioned individually. The parts that make up the assembled item must be requisitioned or fabricated and assembled at the level of maintenance indicated by the source code. If the third position code of the SMR code authorizes you to re- place the item, but the source code indicates that the item is assembled at a higher level, order the item from the higher level of maintenance.

**NOTE**

Cannibalization or controlled exchange, when authorized, may be used as a source of supply for items with the preceding source codes, except for those source coded "XA."

- XA - DO NOT requisition an "XA"-coded item. Order its next higher assembly.
- XB - If an "XB" item is not available from salvage, order it using the CAGEC and part number given.
- XC - Installation drawing, diagram, instruction sheet, or field service drawing that is identified by manufacturer's part number.
- XD - Item is not stocked. Order an "XD"-coded item through normal supply channels using the CAGEC and part number given if no NSN is available.

(2) **Maintenance Code.** Maintenance codes tell you the level(s) of maintenance authorized to use and repair support items. The maintenance codes are entered in the third and fourth positions of the SMR code as follows:

- (a) The maintenance code entered in the third position tells you the lowest maintenance level authorized to remove, replace, and use an item. The maintenance code entered in the third position will indicate authorization to one of the following levels of maintenance:

<u>Code</u>	<u>Application/Explanation</u>
C	Crew or operator maintenance done within Unit maintenance or Aviation Unit maintenance.
O	Unit maintenance or Aviation Unit can remove, replace, and use the item.
F	Direct Support or Aviation Intermediate level can remove, replace, and use the item.
H	General Support level can remove, replace, and use the item.
L	Specialized repair activity (SRA) can remove, replace, and use the item.
D	Depot level can remove, replace, and use the item.

**E-3. EXPLANATION OF COLUMNS (SECTIONS II AND III) (continued).****NOTE**

If authorized by the maintenance allocation chart (MAC) and SMR codes, some limited repair may be done on an item at a lower level of maintenance.

- (b) The maintenance code entered in the fourth position tells whether the item is to be repaired and identifies the lowest maintenance level with the capability to do complete repair (i.e., perform all authorized "Repair" functions). This position will contain one of the following maintenance codes:

<u>Code</u>	<u>Application/Explanation</u>
O	Unit maintenance or Aviation Unit is the lowest level that can do complete repair of the item.
F	Direct Support or Aviation Intermediate is the lowest level than can do complete repair of the item.
H	General Support is the lowest level that can do complete repair of the item.
L	SRA is the lowest level that can do complete repair of the item.
D	Depot is the lowest level that can do complete repair of the item.
Z	Nonrepairable. No repair is authorized.
B	No repair is authorized. (No parts or special tools are authorized for the maintenance of a "B"-coded item.) However, the item may be reconditioned by adjusting, lubricating, etc., at the user level.

- (3) **Recoverability Code.** Recoverability codes are assigned to items to indicate the disposition action on unserviceable items. The recoverability code is entered in the fifth position of the SMR code as follows:

<u>Code</u>	<u>Application/Explanation</u>
Z	<i>Nonrepairable item.</i> When unserviceable, condemn and dispose of the item at the level of maintenance shown in the third position of the SMR code.
O	<i>Repairable item.</i> When uneconomically repairable, condemn and dispose of the item at Unit maintenance or Aviation Unit level.
F	<i>Repairable item.</i> When uneconomically repairable, condemn and dispose of the item at the Direct Support or Aviation Intermediate level.
H	<i>Repairable item.</i> When uneconomically repairable, condemn and dispose of the item at the General Support level.
D	<i>Repairable item.</i> When beyond lower-level repair capability, return to Depot. Condemnation and disposal of the item is not authorized below Depot level.
L	<i>Repairable item.</i> Condemnation and disposal of the item is not authorized below SRA.
A	Item requires special handling or condemnation procedures for specific reasons (e.g., precious metal content, high dollar value, critical material, or hazardous material). Refer to appropriate manuals/directives for specific instructions.

**E-3. EXPLANATION OF COLUMNS (SECTIONS II AND III) (continued).**

- c. **CAGEC [Column (3)].** The CAGEC is a five-digit alphanumeric code used to identify the manufacturer, distributor, or Government agency, etc., that supplies the item.

**NOTE**

When you use an NSN to requisition an item, the item you receive may have a part number different from the part ordered.

- d. **PART NUMBER [COLUMN (4)].** Indicates the primary number used by the manufacturer (individual, company, firm, corporation, or Government activity), which controls the design and characteristics of the item by means of its engineering drawings, specifications standards, and inspection requirements, to identify an item or range of items.
- e. **DESCRIPTION AND USABLE-ON CODE (UOC) [Column (5)].** This column includes the following information:
- (1) The Federal item name and, when required, a minimum description to identify the item.
  - (2) Physical security classification. Not applicable.
  - (3) Items that are included in kits and sets are listed below the name of the kit or set on Figure KIT.
  - (4) Spare/repair parts that make up an assembled item are listed immediately following the assembled item line entry.
  - (5) Part numbers for bulk materials are referenced in this column in the line item entry for the item to be manufactured/fabricated.
  - (6) When the item is not used with all serial numbers of the same model, the effective serial numbers are shown on the last line(s) of the description (before UOC).
  - (7) The UOC, when applicable (see para E-5, Special Information).
  - (8) In the Special Tools List section, the Basis of Issue (BOI) appears as the last line(s) in the entry for each special tool, special TMDE, and other special support equipment. When density of equipments supported exceeds density spread indicated in the BOI, the total authorization is increased proportionately.
  - (9) The statement "END OF FIGURE" appears just below the last item description in Column 5 for a given figure in both Section II and Section III.
- f. **QTY [Column (6)].** The QTY (quantity per figure) column indicates the quantity of the item used in the breakout shown on the illustration/figure, which is prepared for a functional group, subfunctional group, or an assembly. A "V" appearing in this column in lieu of a quantity indicates that the quantity is variable and the quantity may vary from application to application.

- a. **National Stock Number (NSN) Index.**

- (1) **STOCK NUMBER Column.** This column lists the NSN by NIIN sequence. The NIIN consists of the last nine digits of the NSN (i.e.,

$$\frac{\text{NSN}}{\text{NIIN}}$$
 5305-01-674-1467). When using this column to locate an item, ignore the first four digits

of the NSN. However, the complete NSN should be used when ordering items by stock number.

---

**E-4. EXPLANATION OF COLUMNS (SECTION IV).**


---

- (2) **FIG. Column.** This column lists the number of the figure where the item is identified/located. The figures are in numerical order in Section II and Section III.
  - (3) **ITEM Column.** The item number identifies the item associated with the figure listed in the adjacent FIG. column. This item is also identified by the NSN listed on the same line.
- b. **Part Number Index.** Part numbers in this index are listed by part number in ascending alphanumeric sequence (i.e., vertical arrangement of letter and number combination that places the first letter or digit of each group in order A through Z, followed by the numbers 0 through 9 and each following letter or digit in like order).
- (1) **CAGEC Column.** The CAGEC is a five-digit alphanumeric code used to identify the manufacturer, distributor, or Government agency, etc., that supplies the item.
  - (2) **PARTNUMBER Column.** Indicates the primary number used by the manufacturer (individual, firm, corporation, or Government activity), which controls the design and characteristics of the item by means of its engineering drawings, specifications standards, and inspection requirements, to identify an item or range of items.
  - (3) **STOCK NUMBER Column.** This column lists the NSN for the associated part number and manufacturer identified in the PART NUMBER and CAGEC columns to the left.
  - (4) **FIG. Column.** This column lists the number of the figure where the item is identified/located in Section II and Section III.
  - (5) **ITEM Column.** The item number is that number assigned to the item as it appears in the figure referenced in the adjacent figure number column.
- c. **Figure and Item Number Index.**
- (1) **FIG. Column.** This column lists the number of the figure where the item is identified/located in Sections II and III.
  - (2) **ITEM Column.** The item number is that number assigned to the item as it appears in the figure referenced in the adjacent figure number column.
  - (3) **STOCK NUMBER Column.** This column lists the NSN for the item.
  - (4) **CAGEC Column.** The CAGEC is a five-digit alphanumeric code used to identify the manufacturer, distributor, or Government agency, etc., that supplies the item.
  - (5) **PART NUMBER Column.** Indicates the primary number used by the manufacturer (individual, firm, corporation, or Government activity), which controls the design and characteristics of the item by means of its engineering drawings, specifications standards, and inspection requirements, to identify an item or range of items.

---

**E-5. SPECIAL INFORMATION.**


---

- a. Usable-On Code. Usable-on codes are shown as "UOC:" in the *Description* column on the first line after the applicable item description/nomenclature. Uncoded items are applicable to all models. Identification of the usable-on codes used in the RPSTL are as follows:



---

**E-5. SPECIAL INFORMATION (continued).**


---

263	M101A2
TC1	M101A3
258	M116A2
SPR	M116A2E1
CT1	M116A3

- b. **Fabrication Instructions.** Bulk materials required to manufacture items are listed in the Bulk Material Functional Group of this RPSTL. Part numbers for bulk material are also referenced in the DESCRIPTION column of the line item entry for the item to be manufactured/fabricated. Detailed fabrication instructions for items source coded to be manufactured or fabricated are found in Appendix G of this manual.
- c. **Assembly Instructions.** Detailed assembly instructions for items source coded to be assembled from component spare/repair parts are found in Chapters 4 and 5. Items that make up the assembly are listed immediately following the assembly item entry, or reference is made to an applicable figure.
- d. **Kits.** Line item entries for repair parts kits appear in group 9401 in Section II.
- e. **Index Numbers.** Items that have the work *BULK* in the *FIG.* column will have an index number shown in the item column. This index number is a cross-reference between the NSN/part number index and the bulk materials list in Section II.
- f. **Associated Publications.** Not applicable.

---

**E-6. HOW TO LOCATE REPAIR PARTS.**


---

- a. **When National Stock Number or Part Number Is Not Known:**
  - (1) *First.* Using the Table of Contents, determine the assembly group or subassembly group to which the item belongs. This is necessary because figures are prepared for assembly groups and subassembly groups, and listings are divided into the same groups.
  - (2) *Second.* Find the figure covering the assembly group or subassembly group to which the item belongs.
  - (3) *Third.* Identify the item on the figure and use the Figure and Item Number Index to find the NSN.
- b. **When National Stock Number or Part Number Is Known:**
  - (1) *First.* Using the National Stock Number Index or Part Number Index, find the pertinent NSN or part number. The National Stock Number Index is in NIIN sequence (see para E-4a[1]). The part numbers in the Part Number Index are listed in ascending alphanumeric sequence (see para E-4b). Both indexes cross-reference you to the illustration/figure and item number of the item you are looking for.
  - (2) *Second.* Turn to the figure and item number, verify that the item is the one you're looking for, then locate the item number in the repair parts list for the figure.

---

**E-7. ABBREVIATIONS.**


---

For standard abbreviations see MIL-STD-12, Military Standard Abbreviations for Use on Drawings, Specifications, Standards, and in Technical Documents.

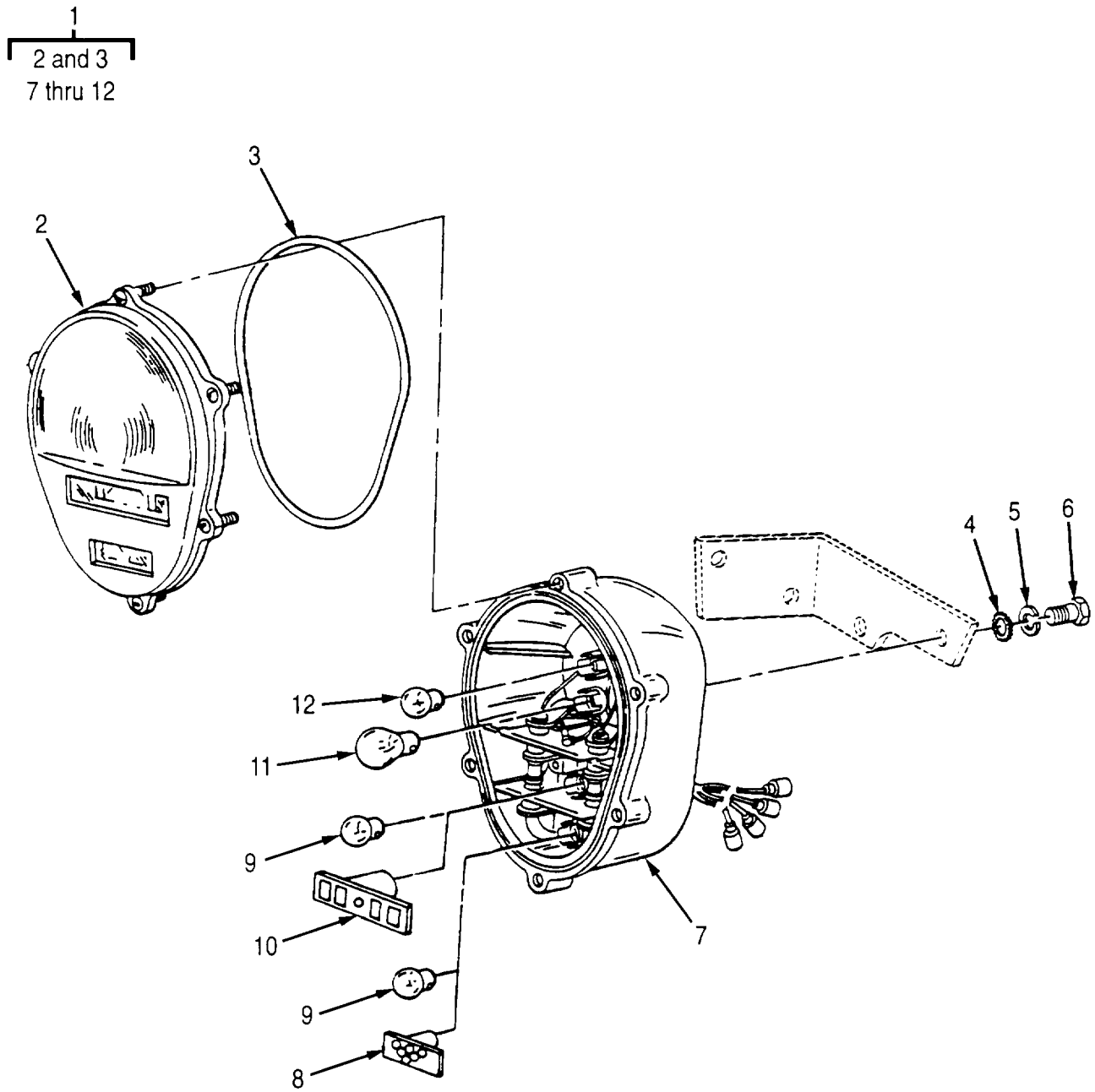


Figure 1. Composite Stoplight-Taillight

SECTION II

TM 9-2330-202-14&P

(1) ITEM NO	(2) SMR CODE	(3) NSN	(4) CAGEC	(5) PART NUMBER	(6) DESCRIPTION AND USABLE ON CODE (UOC)	(7) QTY
GROUP 06 ELECTRICAL SYSTEM						
GROUP 0609 LIGHTS						
FIG. 1 COMPOSITE STOPLIGHT-TAILLIGHT						
1	PAOZZ	6220013723883	19207	12375837	TAILLIGHT, VEHICULAR COMPOSITE MARKER .....	1
2	PAOZZ	6220013592870	19207	12375841	.LENS, LIGHT .....	1
3	PAOZZ	5330004620907	19207	11639519-2	.PACKING, PREFORMED .....	1
4	PAOZZ	5310000611258	96906	MS45904-76	WASHER, LOCK .....	2
5	PAOZZ	5310006379541	96906	MS35338-46	WASHER, LOCK .....	2
6	PAOZZ	5305011409118	80204	B1821BH038C088N	SCREW, CAP, HEXAGON H .....	2
7	XAOZZ		19207	12375838	.BODY ASSEMBLY .....	1
8	PAOZZ	6220012932627	19207	12360870-1	.STOP LIGHT, VEHICULA..... 12V	1
8	PAOZZ	6220012973217	19207	12360870-2	.STOP LIGHT, VEHICULA..... 24V	1
9	PAOZZ	6240000190877	96906	MS15570-1251	.LAMP, INCANDESCENT ..... 24V	2
9	PAOZZ	6240001558717	81348	W-L-00111/60	.LAMP, INCANDESCENT ..... 12V	2
UOC:CT1, 258, 263						
10	PAOZZ	6220012842709	19207	12360850-1	.LIGHT, MARKER, CLEARA..... 24V	1
11	PAOZZ	6240000446914	96906	MS35478-1683	.LAMP, INCANDESCENT ..... 24V	1
11	PAOZZ	6240006170991	96906	MS35478-1073	.LAMP, INCANDESCENT ..... 12V	1
UOC:CT1, SPR, 258, 263						
12	PAOZZ	6240000193093	96906	MS15570-623	.LAMP, INCANDESCENT ..... 24V	
12	PAOZZ	6240001433159	96906	MS15570-89	.LAMP, INCANDESCENT ..... 12V	1
UOC:CT1, SPR, 258, 263						

END OF FIGURE

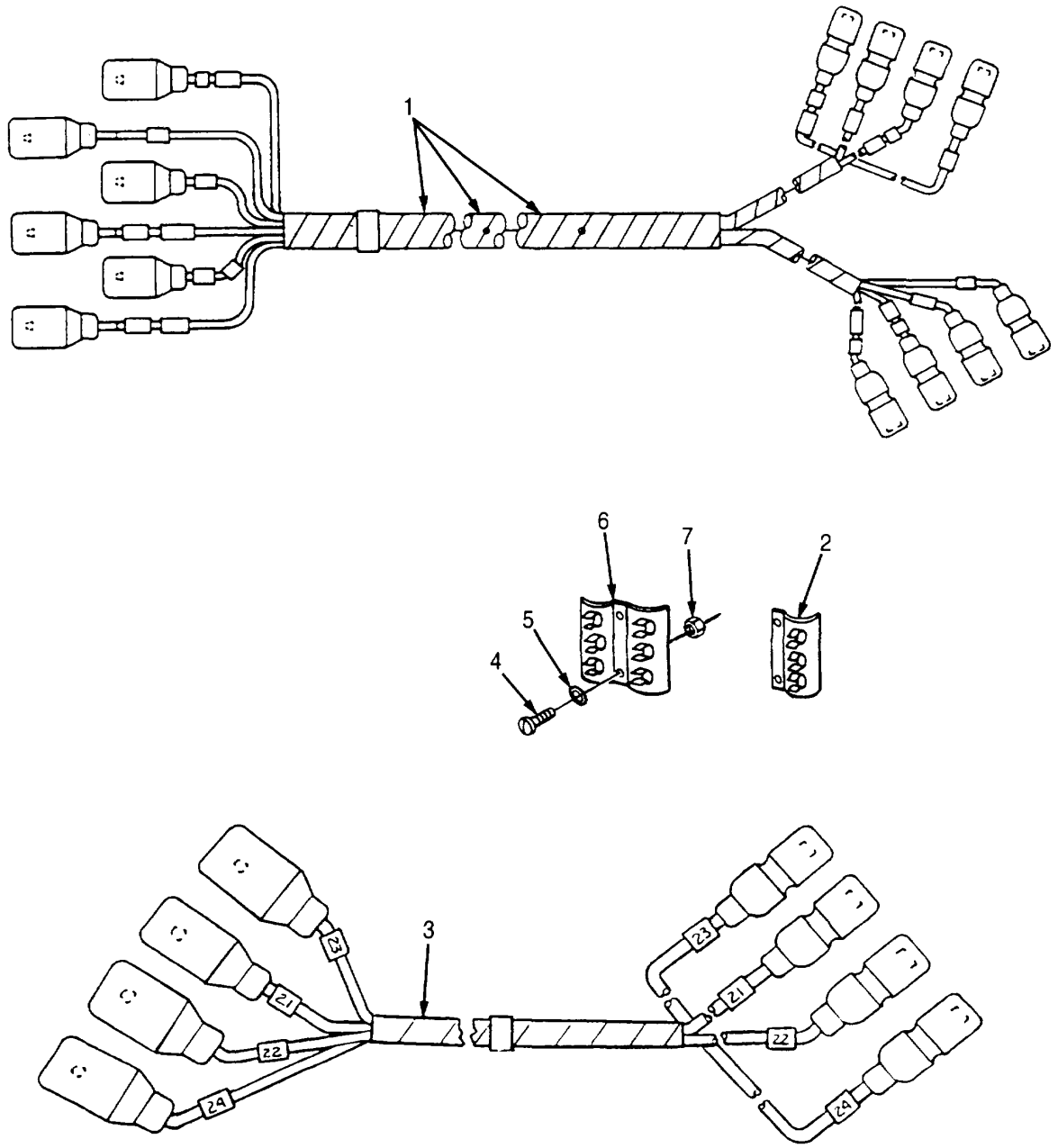


Figure 2. Chassis Wiring Harness ( Composite Stoplight-Tailight)

## SECTION II

TM 9-2330-202-14&amp;P

(1) ITEM NO	(2) SMR CODE	(3) NSN	(4) CAGEC	(5) PART NUMBER	(6) DESCRIPTION AND USABLE ON CODE (UOC)	(7) QTY
					GROUP 0613 HULL OR CHASSIS WIRING HARNESS	
					FIG. 2 CHASSIS WIRING HARNESS (COMPOSITE STOPLIGHT-TAILLIGHT)	
1	PAOZZ	6150011671827	19207	11652180	WIRING HARNESS (USED ON VEHICLES W/ COMPOSITE STOPLIGHT-TAILLIGHT) .....	1
					UOC:258, 263	
1	PAOZZ		19207	11652180-2	WIRING HARNESS, BRAN USED ON VEHICLES W/COMPOSITE STOPLIGHT-TAILLIGHT .....	1
					UOC:CT1, SPR, TC1	
2	PAOZZ	5340000402364	19207	8347212	CLIP ASSEMBLY .....	1
					UOC:258, 263	
2	PAOZZ	2590008329976	19207	8722943	CLIP ASSEMBLY, CONNE .....	2
					UOC:CT1, SPR, TC1	
2	PAOZZ	5340008600555	19207	8722870	CLIP, SPRING TENSION .....	2
					UOC:CT1, SPR, TC1	
3	PAOZZ		19207	12441077	WIRING HARNESS, EXTE .....	2
4	PAOZZ	5305008813824	19207	171591	SCREW, TAPPING .....	4
					UOC:258, 263	
4	PAOZZ	5305009846210	96906	MS35206-263	SCREW, MACHINE .....	4
					UOC:CT1, SPR, TC1	
5	PAOZZ	5310002857037	96906	MS122031	WASHER, LOCK .....	4
					UOC:258, 263	
5	PAOZZ	5310000453296	96906	MS35338-43	WASHER, LOCK .....	4
					UOC:CT1, SPR, TC1	
6	PAOZZ	5340000402365	19207	8347213	CLIP, SPRING TENSION .....	1
					UOC:258, 263	
7	PAOZZ	5310009349758	96906	MS35649-202	NUT, PLAIN, HEXAGON .....	4
					UOC:CT1, SPR, TC1	

END OF FIGURE

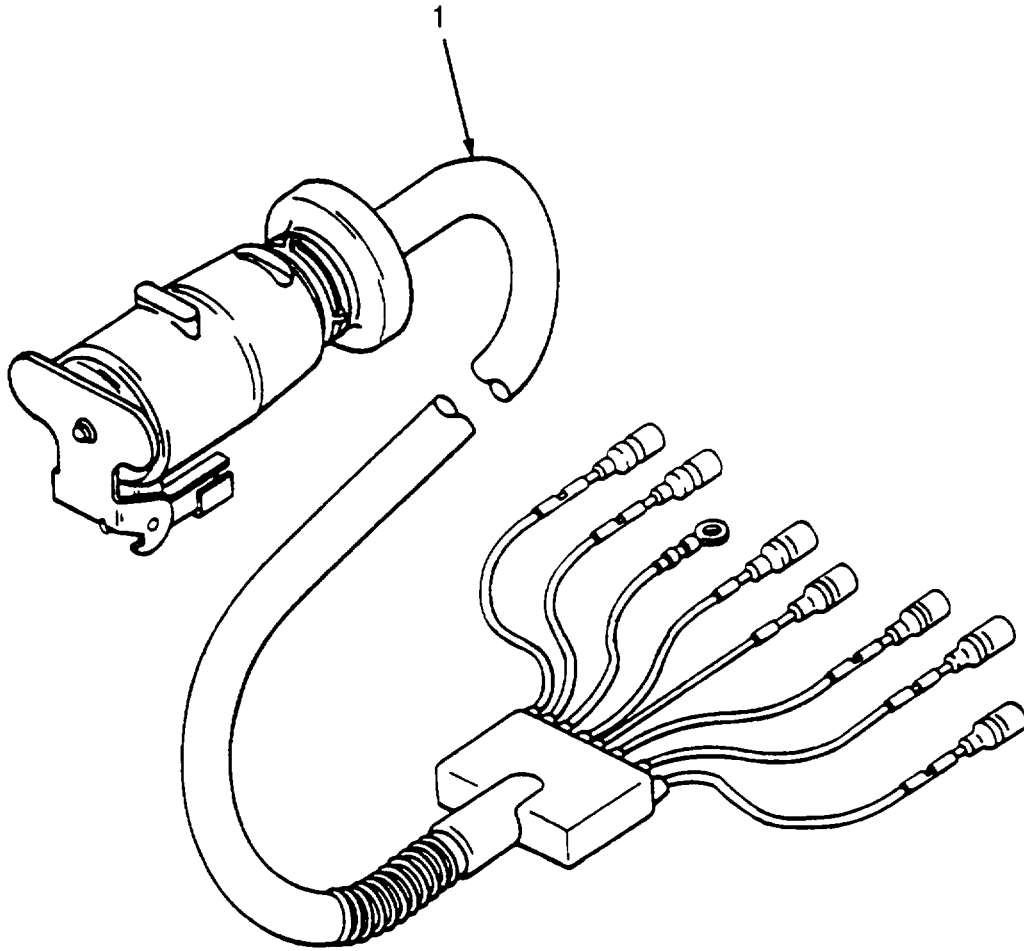


Figure 3. Intervehicular Cable

## SECTION II

TM 9-2330-202-14&amp;P

(1) ITEM NO	(2) SMR CODE	(3) NSN	(4) CAGEC	(5) PART NUMBER	(6) DESCRIPTION AND USABLE ON CODE (UOC)	(7) QTY
-------------------	--------------------	------------	--------------	-----------------------	--	------------

1	PAOZZ	6150008306672	19207	8722865	GROUP 0613 HULL OR CHASSIS WIRING HARNESS  FIG. 3 INTERVEHICULAR CABLE  CABLE ASSEMBLY, SPEC INTERVEHICULAR..	1
---	-------	---------------	-------	---------	--	---

END OF FIGURE

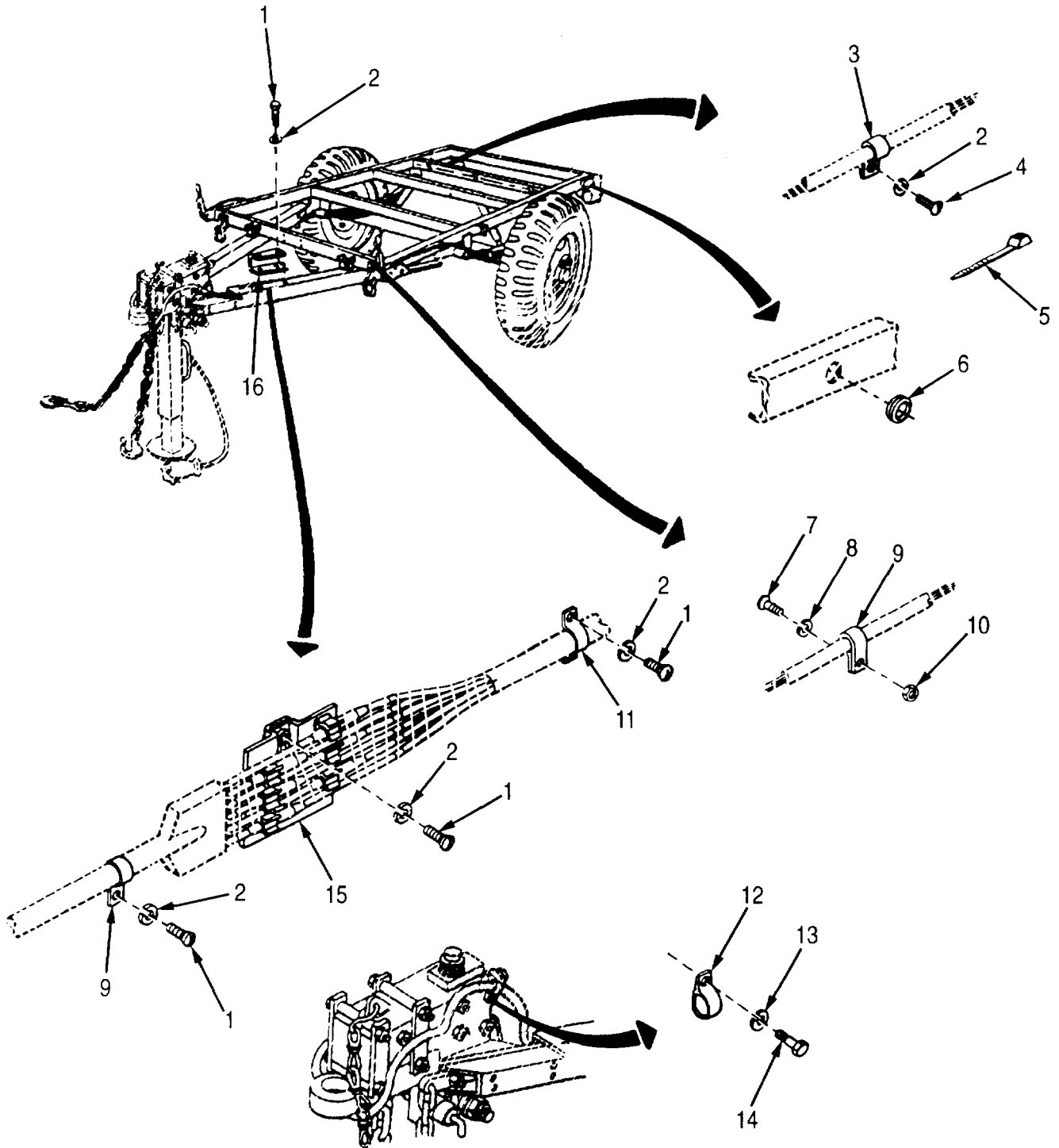


Figure 4. Wiring Harness and Intervehicular Cable Attachments



## SECTION II

TM 9-2330-202-14&amp;P

(1) ITEM NO	(2) SMR CODE	(3) NSN	(4) CAGEC	(5) PART NUMBER	(6) DESCRIPTION AND USABLE ON CODE (UOC)	(7) QTY
GROUP 0613 HULL OR CHASSIS WIRING HARNESS						
FIG. 4 WIRING HARNESS AND INTERVEHICULAR CABLE ATTACHMENTS						
1	PAOZZ	5305008550957	96906	MS24629-46	SCREW, TAPPING .....	11
2	PAOZZ	5310003952948	96906	MS45904-64	WASHER, LOCK .....	9
3	XBOZZ		19207	7979250	CLAMP, LOOP .....	10
4	PAOZZ	5305004324203	96906	MS51861-47	SCREW, TAPPING .....	10
5	PAOZZ	5975000742072	96906	MS3367-1-9	STRAP, TIEDOWN, ELECT .....	2
UOC:CT1, SPR, TC1						
6	PAOZZ	5325001850001	96906	MS35489-46	GROMMET, NONMETALLIC .....	2
7	PAOZZ	5305009846210	96906	MS35206-263	SCREW, MACHINE .....	1
8	PAOZZ	5310000453296	96906	MS35338-43	WASHER, LOCK .....	1
9	PAOZZ	5340002827515	96906	MS21333-37	CLAMP, LOOP .....	2
10	PAOZZ	5310009349758	96906	MS35649-202	NUT, PLAIN, HEXAGON. ....	1
11	PAOZZ	5340001777832	19207	8382973	STRAP, RETAINING .....	1
12	PAOZZ	5340011321175	19207	7336030	CLAMP, LOOP .....	1
13	PAOZZ	5310006379541	96906	MS35338-46	WASHER, LOCK .....	1
14	PAOZZ	5305002693234	96906	MS90727-58	SCREW, CAP, HEXAGON H .....	1
15	PAOZZ	5340008600555	19207	8722870	CLIP, SPRING TENSION .....	2
16	PAOZZ	5975011703480	19207	10924576	COVER, JUNCTION BOX .....	1

END OF FIGURE

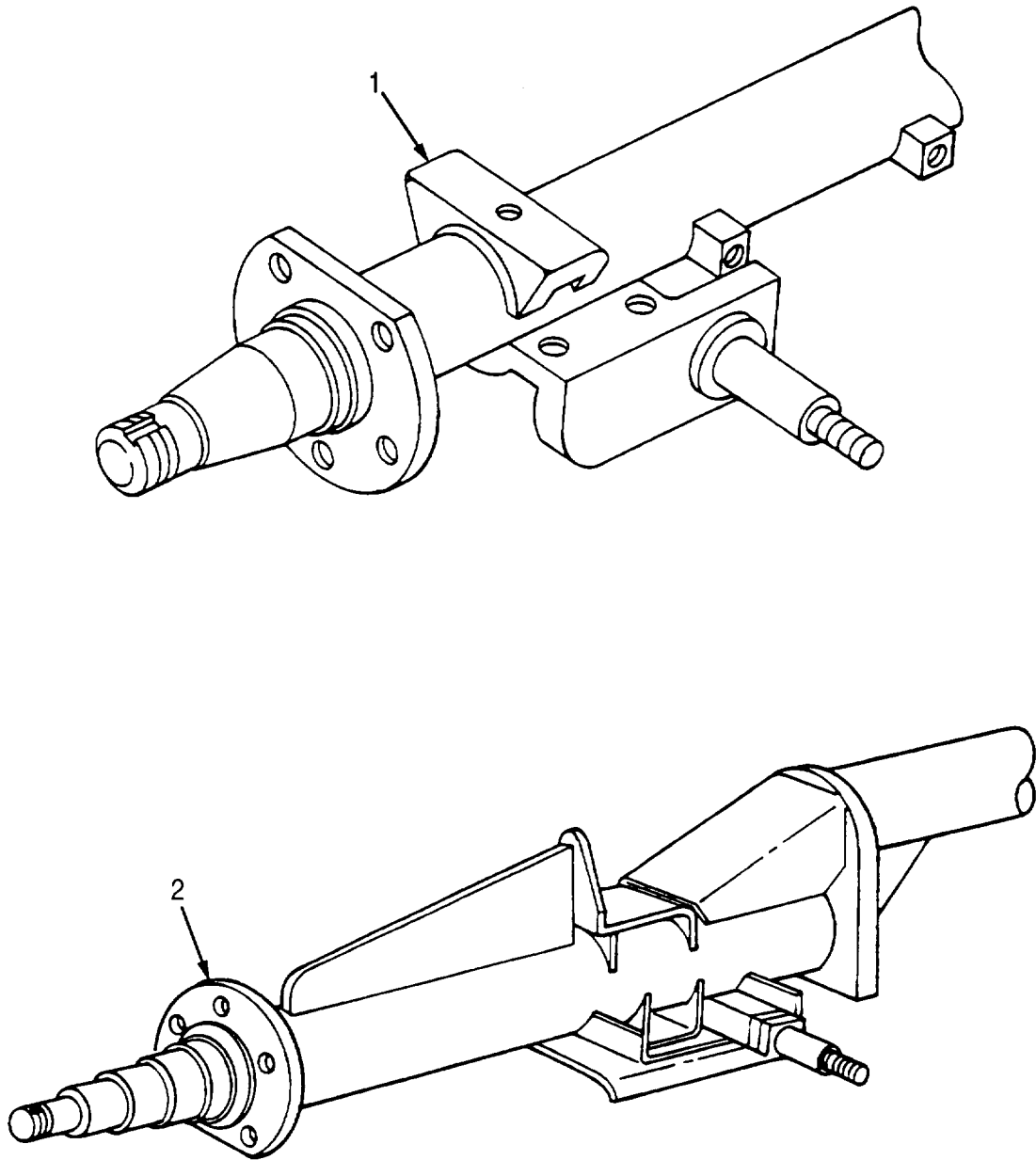


Figure 5. Rear Axle Assembly

SECTION II

TM 9-2330-202-14&P

(1) ITEM NO	(2) SMR CODE	(3) NSN	(4) CAGEC	(5) PART NUMBER	(6) DESCRIPTION AND USABLE ON CODE (UOC)	(7) QTY
					GROUP 11 REAR AXLE	
					GROUP 1100 REAR AXLE ASSEMBLY	
					FIG. 5 REAR AXLE ASSEMBLY	
1	PAFZZ	2530011389385	19207	12313006	AXLE, VEHICULAR, NOND W/FLANGE AND SPRING SEAT ASSEMBLY .....	1
					UOC:SPR, 258, 263	
2	PFFZZ	2530013904684	19207	12362791	AXLE, VEHICULAR, NOND OFFSET .....	1
					UOC:CT1, TC1	
					END OF FIGURE	

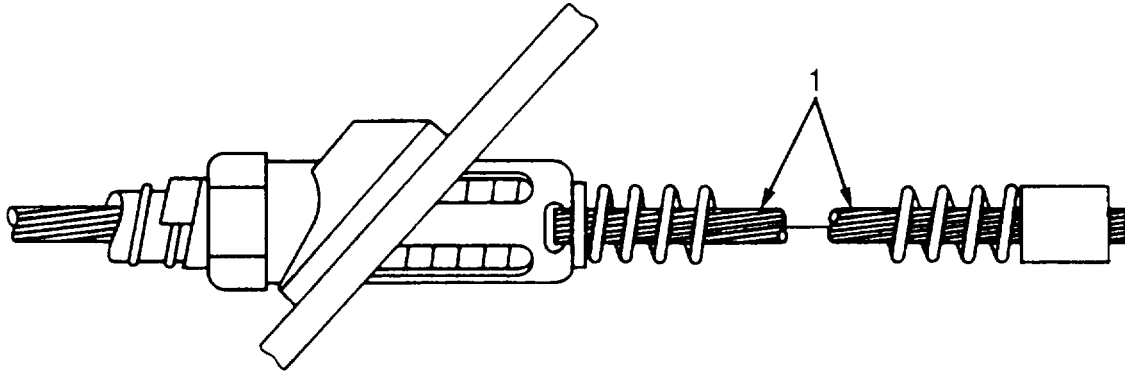


Figure 6. Cable and Conduit Assembly

SECTION II

TM 9-2330-202-14&P

(1) ITEM NO	(2) SMR CODE	(3) NSN	(4) CAGEC	(5) PART NUMBER	(6) DESCRIPTION AND USABLE ON CODE (UOC)	(7) QTY
					GROUP 12 BRAKES	
					GROUP 1201 HANDBRAKES	
					FIG. 6 CABLE AND CONDUIT ASSEMBLY	
1	PAOZZ	6150011687906	19207	11686101	CABLE AND CONDUIT A ..... UOC:CT1, SPR, 258, 263	1
1	PAOZZ	2530014298346	92867	15641500	CONTROL ASSEMBLY P/ ..... UOC:TC1	1
					END OF FIGURE	

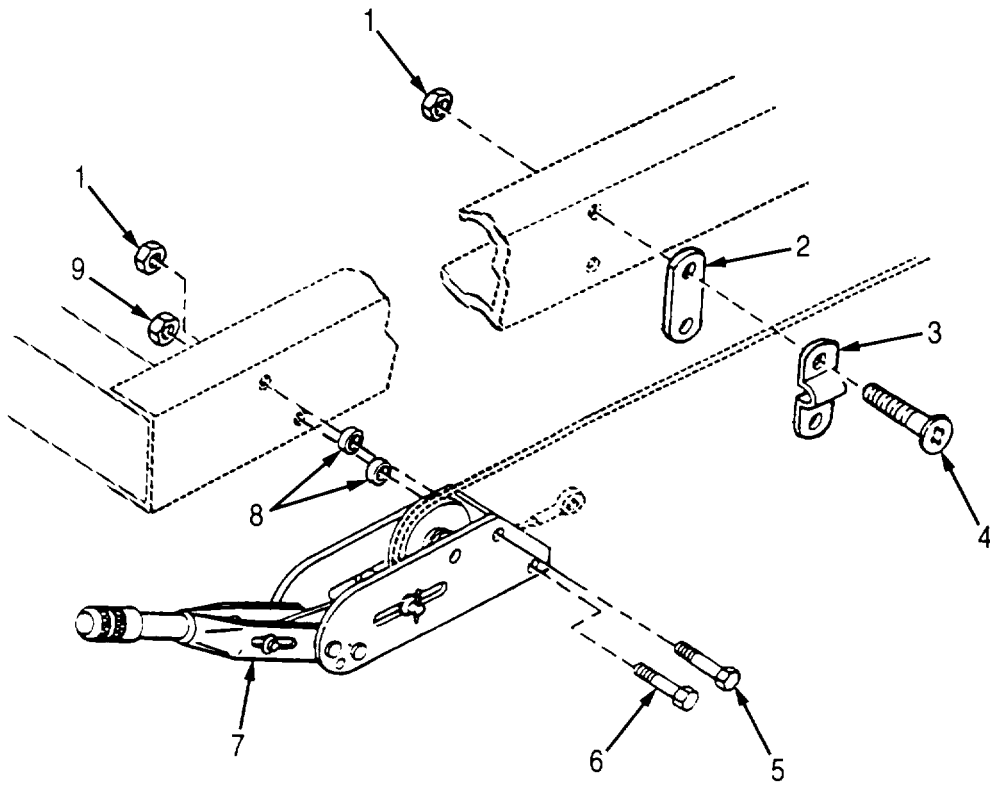


Figure 7. Handbrake Lever

SECTION II

TM 9-2330-202-14&P

(1) ITEM NO	(2) SMR CODE	(3) NSN	(4) CAGEC	(5) PART NUMBER	(6) DESCRIPTION AND USABLE ON CODE (UOC)	(7) QTY
GROUP 1201 HANDBRAKES						
FIG.7 HANDBRAKE LEVER						
1	PAOZZ	5310008071469	96906	MS21042-5	NUT, SELF-LOCKING, EX .....	5
2	PAOZZ	5365004758291	19207	10926075	SPACER, PLATE BRAKE CABLE .....	1
3	PAOZZ	5340010704475	19207	10926074	STRAP, RETAINING BRAKE CABLE .....	1
4	PAOZZ	5305009580605	96906	MS35207-298	SCREW, MACHINE .....	2
5	PAOZZ	5306002259096	96906	MS90726-41	BOLT, MACHINE .....	1
6	PAOZZ	5305002692811	96906	MS90726-67	SCREW, CAP, HEXAGON H .....	1
7	PAOZZ	5340009365284	19207	10926073	LEVER, MANUAL CONTRO .....	1
8	PAOZZ	5310011392070	19207	10926094	WASHER, FLAT .....	2
9	PAOZZ	5310008101786	96906	MS21042-6	NUT, SELF-LOCKING, EX .....	1
END OF FIGURE						





## SECTION II

TM 9-2330-202-14&amp;P

(1) ITEM NO	(2) SMR CODE	(3) NSN	(4) CAGEC	(5) PART NUMBER	(6) DESCRIPTION AND USABLE ON CODE (UOC)	(7) QTY
GROUP 1202 SERVICE BRAKES						
FIG.8 BRAKE ASSEMBLY						
1	PAOZZ	2530012876869	94489	18496	PLATE, BACKING, BRAKE LEFT OR RIGHT HAND SIDE .....	1
1	PAOZZ		14892	3202065	PLATE, BACKING, BRAKE RIGHT .....	1
2	PAOZZ	5315010791494	19207	11686273	PIN, TOGGLE, HEADED .....	2
3	PAOZZ	5305002693236	96906	MS90727-60	SCREW, CAP, HEXAGON H .....	5
4	PAOZZ	5340010712098	19207	11686276	COVER, ACCESS .....	1
5	PAOZZ	5310006379541	96906	MS35338-46	WASHER, LOCK .....	5
6	PAOZZ	5310007320559	96906	MS51968-8	NUT, PLAIN, HEXAGON .....	5
7	PAOZZ	5340010696705	19207	11686262-1	LEVER, LOCK-RELEASE .....	1
7	PAOZZ	3040008728567	19207	11686262-2	LEVER, MANUAL CONTRO .....	1
8	PAOZZ	5310008742922	19207	11686280	WASHER, SPRING TENSI .....	1
9	PAOZZ	5120010749323	19207	11686281	CLAMP, BRAKE LINING .....	1
10	PAOZZ	2530012169259	19204	11838714	BRAKE SHOE SET SET CONTAINS 4 BRAKE SHOES .....	1
11	PAOZZ	5360003840025	19207	11686270	SPRING, HELICAL, EXTE .....	1
12	PAOZZ	2530014307250	19207	12448059	STRUT PARKING BRAKE .....	1
13	PAOZZ	5305010709494	19207	11686257	SCREW, ADJUSTING .....	1
14	PAOZZ	5360008772964	19207	11686279	SPRING, HELICAL, COMP .....	1
15	PAOZZ	5360003840004	19207	11686272	SPRING, HELICAL, EXTE .....	2
16	PAOZZ	5340010686693	19207	11686275	RETAINER, HELICAL CO .....	2
17	PAOZZ	5360010880552	19207	11686274	SPRING, HELICAL, COMP .....	2
18	PAOZZ	1005010839297	19207	11686271	PLATE, SHOE GUIDE .....	1

END OF FIGURE

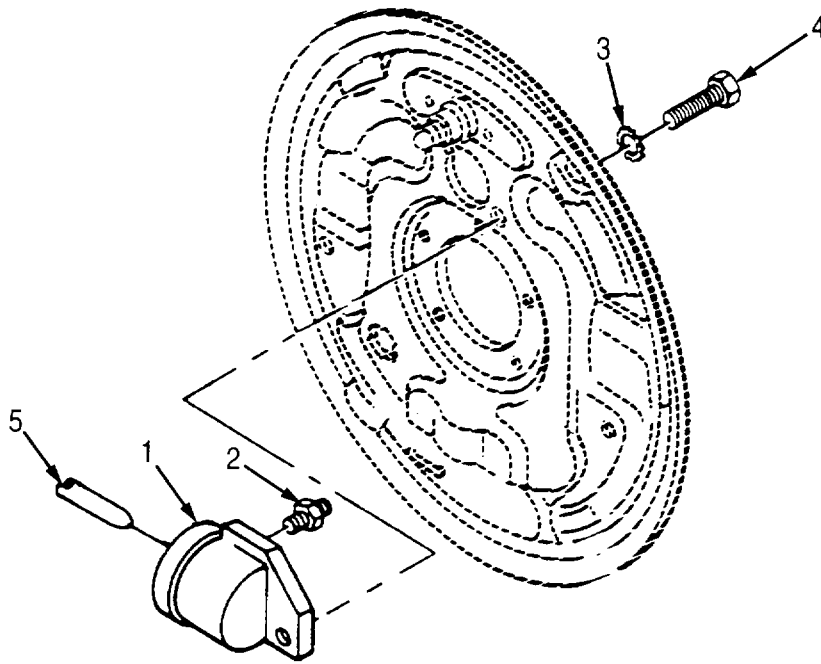


Figure 9. Wheel Cylinder

SECTION II

TM 9-2330-202-14&P

(1) ITEM NO	(2) SMR CODE	(3) NSN	(4) CAGEC	(5) PART NUMBER	(6) DESCRIPTION AND USABLE ON CODE (UOC)	(7) QTY
----------------	-----------------	------------	--------------	--------------------	---	------------

GROUP 1204 HYDRAULIC BRAKE SYSTEM

FIG. 9 WHEEL CYLINDER

1	PAOZZ	2530001617576	19207	11686267-1	CYLINDER LEFT .....	1
1	PAOZZ	2530001617575	19207	11686267-2	CYLINDER RIGHT.....	1
2	PAOZZ	2530011600850	14892	049206	BLEEDER VALVE, HYDRA .....	1
3	PAOZZ	5310005146674	96906	MS35335-34	WASHER, LOCK .....	1
4	PAOZZ	5306002264822	80204	B1821BH031C050N	BOLT, MACHINE .....	1
5	PAOZZ	2530005856079	19207	11686277LINK,	WHEEL CYLINDER .....	1

END OF FIGURE



1	23
2 thru 12, 14 and 15	24
18 thru 22, 25 thru 30	

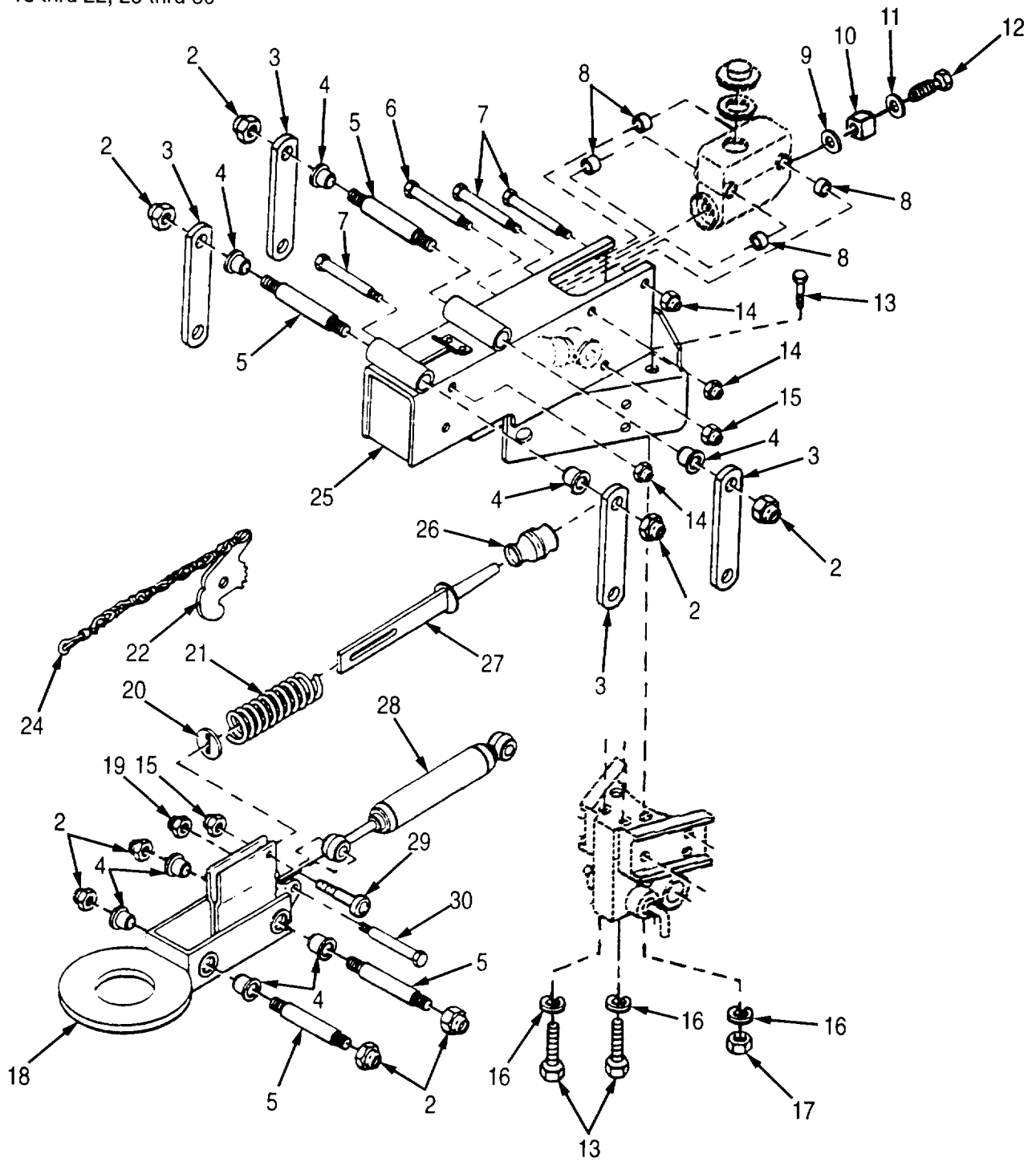


Figure 10. Hydraulic Brake Actuator Assembly (sheet 1 of 2)

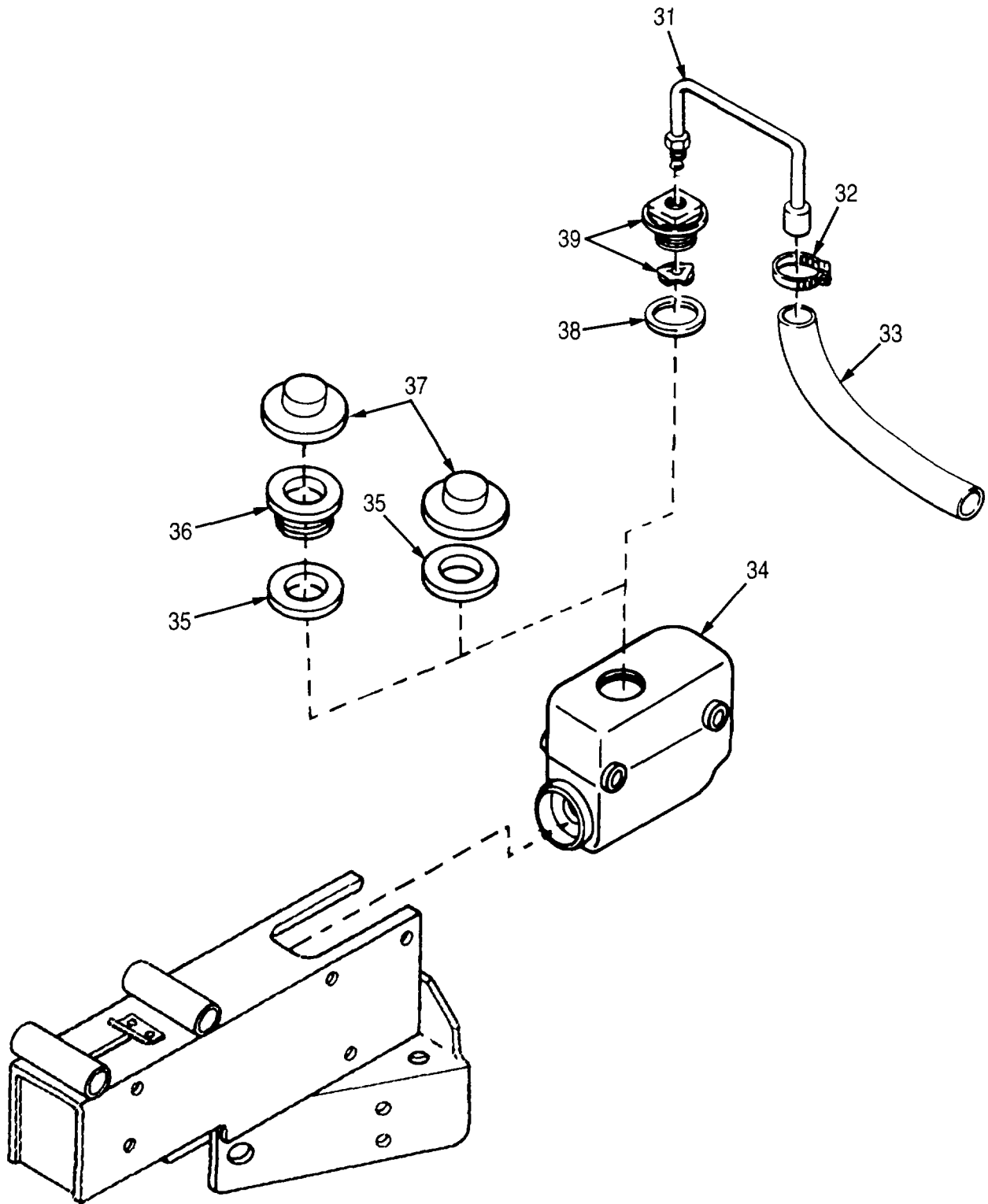


Figure 10. Hydraulic Brake Actuator Assembly (sheet 2 of 2)

SECTION II						TM 9-2330-202-14&P	
(1)	(2)	(3)	(4)	(5)	(6)		
ITEM NO	SMR CODE	CAGEC	PART NUMBER	DESCRIPTION AND USABLE ON CODES (UOC)		QTY	
GROUP 1204 HYDRAULIC BRAKE SYSTEM							
FIG. 10 HYDRAULIC BRAKE ACTUATOR ASSEMBLY							
1	PAOOO	5340013482989	19207	11675013	CATCH, CLAMPING HYDRAULIC BRAKE .....	1	
2	PAOZZ	5310008775795	96906	MS21044N8	. NUT, SELF-LOCKING, HE .....	8	
3	PAOZZ	2540010516355	93072	1808-1	. LINK, CHAIN .....	4	
4	PAOZZ	3120010521151	93072	1745	. BEARING, SLEEVE .....	8	
5	PAOZZ	2540010516354	93072	1829	. SHAFT, CHAIN .....	4	
6	PAOZZ	5305007104205	96906	MS90726-99	. SCREW, CAP, HEXAGON H .....	1	
7	PAOZZ	5305007098423	96906	MS90727-97	. SCREW, CAP, HEXAGON H .....	3	
8	PAOZZ	5365010536898	93072	1841	. SPACER, SLEEVE .....	4	
UOC:258, 263							
9	PAOZZ	5310002756635	19207	5214539	. WASHER, FLAT .....	1	
10	XBOZZ		19207	12362746	. CONNECTOR .....	1	
11	PAOZZ	5310002091761	19207	5160323	. WASHER, FLAT .....	1	
12	PFOZZ	4730010538468	19207	8762000	. BOLT, FLUID PASSAGE .....	1	
13	PAOZZ	5305007195209	96906	MS90727-110	SCREW, CAP, HEXAGON H .....	4	
14	PAOZZ	5310009591488	96906	MS51922-21	. NUT, SELF-LOCKING, HE .....	3	
15	PAOZZ	5310000577080	96906	MS51922-29	. NUT, SELF-LOCKING, HE .....	2	
16	PAOZZ	5310000034094	01276	210104-8S	WASHER, LOCK .....	4	
17	PAOZZ	5310007320560	96906	MS51968-14	NUT, PLAIN, HEXAGON .....	2	
18	PAOZZ	2540010607031	93072	10632	. COUPLER, DRAWBAR, RIN .....	1	
19	PAOZZ	5310000742328	96906	MS21083-C7	. NUT, SELF-LOCKING, HE .....	1	
20	PAOZZ	5310010508832	93072	1840	. WASHER, PUSH ROD .....	1	
21	PAOZZ	5360010542281	93072	1828	. SPRING .....	1	
22	PAOZZ	2530010507698	93072	1804	. LEVER BREAKAWAY .....	1	
23	PAOZZ	4010011586795	19207	12296386	CHAIN ASSEMBLY, SING .....	1	
24	PAOZZ	5340013859852	19207	12331722	. SNAP HOOK .....	1	
25	XAOZZ		19207	12314088	. CHANNEL, STRUCTURAL .....	1	
26	PAOZZ		19207	12356020	. BOOT, MASTER CYL .....	1	
27	PAOZZ	2530011671999	93072	10703	. PUSH ROD, HYDRAULIC .....	1	
28	PAOZZ	2510010507136	93072	1844-2	. SHOCK ABSORBER, DIRE .....	1	
29	PAOZZ	5305009496184	96906	MS51975-2	. SCREW, SHOULDER SOCKET HEAD .....	1	
30	PAOZZ	5305007098542	96906	MS90727-91	. SCREW, CAP, HEXAGON H .....	1	
31	PFOZZ	4710005111692	19207	8365426	TUBE ASSEMBLY, METAL .....	1	
UOC:CT1, TC1							
32	PAOZZ	4730009083194	96906	MS35845-11	CLAMP, HOSE .....	1	
UOC:CT1, TC1							
33	PAOZZ	4720004895350	96906	MS521301A204R	HOSE, NONMETALLIC .....	1	
UOC:CT1, TC1							
34	PAOZZ	2530010508929	93072	10614	CYLINDER ASSEMBLY, H .....	1	
35	PAOZZ	5330002916658	63477	F6019	GASKET .....	1	
36	PAOZZ	2590013882416	93072	622794-X	CAP, FILLER OPENING .....	1	
37	PAOZZ	5340014189889	02686	126945	CAP, FILLER OPENING .....	1	
38	PAOZZ	5330007373354	19207	7373354	GASKET .....	1	
UOC:CT1, TC1							
39	PAOZZ	4730007732163	63477	7979691	CAP, FILLER OPENING .....	1	
UOC:CT1, TC1							

END OF FIGURE

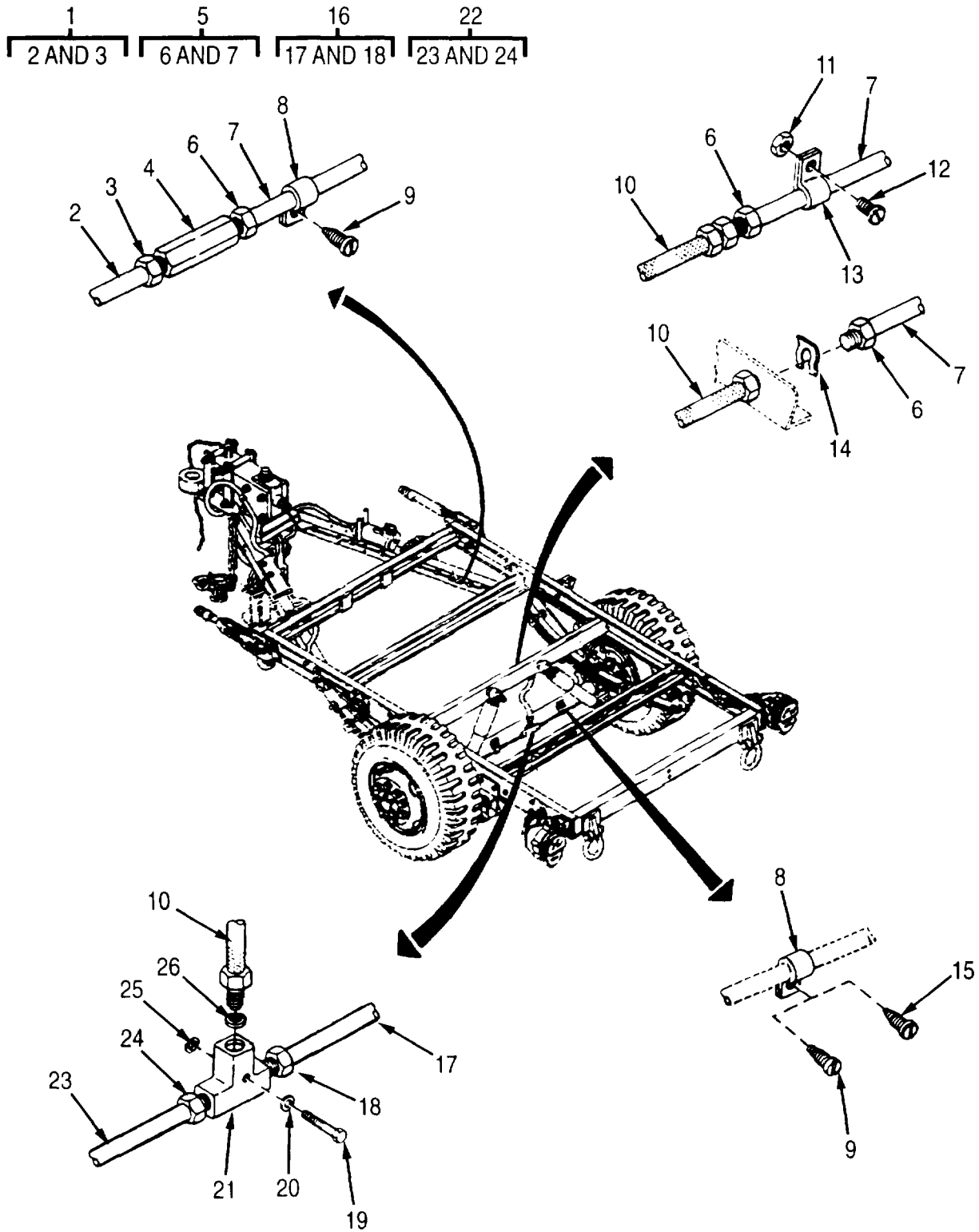


Figure 11. Hydraulic Brake Lines



SECTION II						
(1)	(2)	(3)	(4)	(5)	(6)	
ITEM NO	SMR CODE	CAGEC	PART NUMBER	DESCRIPTION AND USABLE ON CODES (UOC)		QTY
GROUP 1204 HYDRAULIC BRAKE SYSTEM						
FIG. 11 HYDRAULIC BRAKE LINES						
1	AOOOO		19207 11686100	TUBE ASSEMBLY FRONT, MAKE FROM TUBE, P/N 10943231.....		1
				UOC:258, 263		
1	MOOZZ		19207 12354224	TUBE ASSEMBLY MAKE FROM M3520-B80A0OG .....		1
				UOC:CT1, SPR, TC1		
2	MOOZZ		19207 11686100-56.5	. TUBE, BENT METALLIC FRONT, MAKE FROM TUBE P/N 10943231 .....		1
				UOC:258, 263		
2	MOOZZ		19207 12354224-1	. TUBE, BENT METALLIC FRONT, MAKE FROM TUBE P/N M3520-B80A0OG .....		1
				UOC:CT1, SPR, TC1		
3	PAOZZ	5310001344141	21450 110357	. NUT, SPECIAL .....		2
4	PAOZZ	4730002788853	21450 143449	COUPLING, TUBE .....		1
5	AOOOO		19207 11686102	. TUBE ASSEMBLY REAR, MAKE FROM TUBE, P/N 10943231 .....		1
				UOC:258, 263		
5	MOOZZ		19207 12354225	. TUBE ASSEMBLY MAKE FROM M3520-B80A0OG .....		1
				UOC:CT1, SPR, TC1		
6	PAOZZ	5310001344141	21450 10357	. NUT, SPECIAL .....		2
7	MOOZZ		19207 11686102-1X	. TUBE, BENT METALLIC REAR, MAKE FROM TUBE P/N 10943231 .....		1
				UOC:258, 263		
7	MOOZZ		19207 12354225-1	. TUBE, BENT, METALLIC REAR, MAKE FROM TUBE P/N M3520-B80 A0OG .....		1
				UOC:CT1, SPR, TC1		
8	PAOZZ	5340007782738	96906 MS21333-2	CLAMP, LOOP .....		13
9	PAOZZ	5305008550958	96906 MS24629-45	SCREW, TAPPING .....		13
				UOC:258, 263		
9	PAOZZ	5305008550958	96906 MS24629-45	SCREW, TAPPING .....		11
				UOC:CT1, SPR, TC1		
10	PAOZZ	4720013066294	19207 12354199	HOSE ASSEMBLY, NONME .....		1
11	PAOZZ	5310001436102	96906 MS51922-6	NUT, SELF-LOCKING, HE .....		1
				UOC:258, 263		
12	PAOZZ	5305002678953	96906 MS90727-5	SCREW, CAP, HEXAGON H .....		1
				UOC:258, 263		
13	PAOZZ	5340009936207	96906 MS21333-99	CLAMP, LOOP .....		1
				UOC:258, 263		
14	PAOZZ	5365008642993	19207 7735289	RING, RETAINING .....		1
				UOC:CT1, SPR, TC1		
15	PAOZZ	5305008550964	96906 MS24629-48	SCREW, TAPPING .....		2
				UOC:CT1, SPR, TC1		
16	AOOOO		19207 11686103-2	TUBE ASSEMBLY .....		1
				UOC:SPR, 258, 263		
16	MOOZZ		19207 12362795	TUBE ASSEMBLY MAKE FROM M3520-B80A0OG .....		1
				UOC:CT1, TC1		
17	MOOZZ		19207 11686103-2-1X	. TUBE, BENT, METALLIC RIGHT, MAKE FROM TUBE P/N 10943231 .....		1
				UOC:SPR, 258, 263		

SECTION II						
(1)	(2)	(3)	(4)	(5)	(6)	
ITEM NO	SMR CODE	CAGEC	PART NUMBER	DESCRIPTION AND USABLE ON CODES (UOC)	QTY	
17	MOOZZ		19207 12362795-1	. TUBE, BENT, METALLIC RIGHT, MAKE FROM TUBE P/N M3520-B80AOOG ..... UOC:CT1, TC1	1	
18	PAOZZ	5310001344141	21450 110357	. NUT, SPECIAL .....	2	
19	PAOZZ	5305002253843	80204 B1821BH025C100N	SCREW, CAP, HEXAGON H .....	1	
20	PAOZZ	5310008094058	96906 MS27183-10	WASHER, FLAT .....	1	
21	PAOZZ	4730010433055	19207 11625496	TEE, TUBE .....	1	
22	AOOOO		19207 11686103-1	TUBE ASSEMBLY LEFT, MAKE FROM TUBE, P/N 10943231 ..... UOC:SPR, 258, 263	1	
22	MOOZZ		19207 12362796	TUBE ASSEMBLY MAKE FROM M3520-B80AOOG ..... UOC:CT1, TC1	1	
23	MOOZZ		19207 11686103-1-Lx	. TUBE, BENT, METALLIC LEFT, MAKE FROM TUBE P/N 10943231 ..... UOC:SPR, 258, 263	1	
23	MOOZZ		19207 12362796-1	. TUBE, BENT, METALLIC LEFT, MAKE FROM TUBE P/N M3520-B80AOOG ..... UOC:CT1, TC1	1	
24	PAOZZ	5310001344141	21450 110357	. NUT, SPECIAL .....	2	
25	PAOZZ	5310005825965	96906 MS35338-44	WASHER, LOCK .....	1	
26	PAOZZ	5330010441941	19207 11625497	GASKET .....	1	

END OF FIGURE



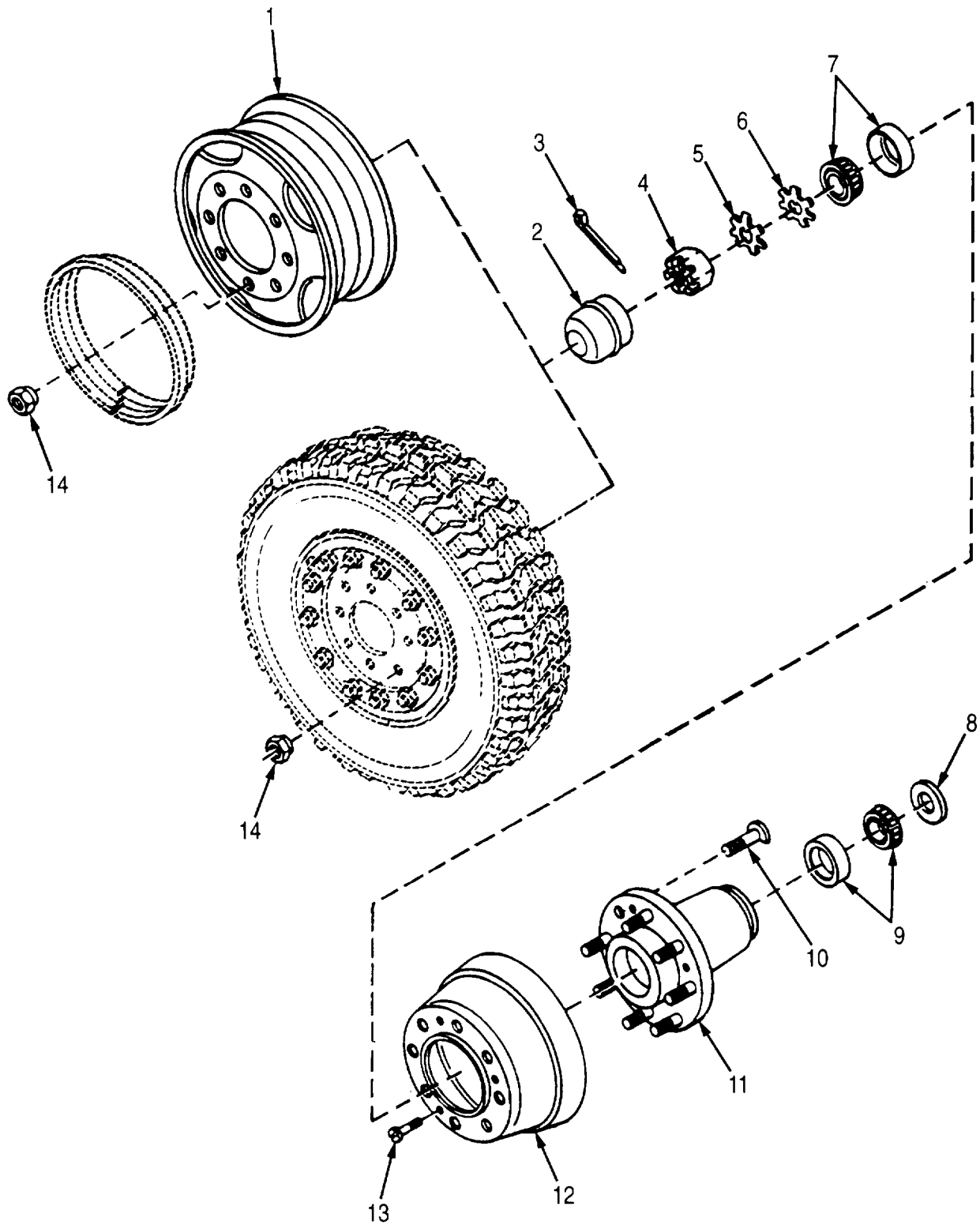


Figure 12. Wheel and Hub Assembly

SECTION II						TM 9-2330-202-14&P	
(1)	(2)	(3)	(4)	(5)		(6)	
ITEM NO	SMR CODE	CAGEC	PART NUMBER	DESCRIPTION AND USABLE ON CODES (UOC)		QTY	
GROUP 13 WHEELS AND TRACKS							
GROUP 1311 WHEEL ASSEMBLY							
FIG. 12 WHEEL AND HUB ASSEMBLY							
1	PAOZZ	2530011546952	11862	14035374	WHEEL, PNEUMATIC TIR .....	1	
					UOC:SPR, 258, 263		
2	PAOZZ	3040011495061	19207	12313048	CAP, GREASE .....	1	
3	PAOZZ	5315000137238	96906	MS24665-425	PIN, COTTER .....	1	
					UOC:CT1, TC1		
3	PAOZZ	5315002368368	96906	MS24665-436	PIN, COTTER .....	1	
					UOC:SPR, 258, 263		
4	PAOZZ	5340011514202	19207	12441093	NUT, CASTELLATED .....	1	
					UOC:CT1, TC1		
5	PAOZA	5310008166352	96906	MS27111-10	WASHER, KEY .....	1	
					UOC:CT1, TC1		
6	PAOZA	5310008166352	96906	MS27111-10	WASHER, KEY .....	1	
					UOC:CT1, TC1, 263		
7	PAOZZ	3110011654860	19207	12313045	BEARING, ROLLER, TAPE .....	1	
8	PAOZZ	5330011408231	19207	12313027	SEAL, PLAIN ENCASED .....	1	
9	PAOZZ	3110001005303	19207	12313046	BEARING, ROLLER, TAPE .....	1	
10	PAOZZ	5306012376844	19207	12354223	BOLT, RIBBED SHOULDE .....	8	
11	PAOZZ	3040011399900	19207	12313010	HUB, BODY .....	1	
12	PAOFF	2530011487074	19207	12313012	BRAKE DRUM .....	1	
13	PAOZZ	5305009585258	96906	MS35190-317	SCREW, MACHINE .....	2	
14	PAOZZ	5310011490868	19207	12313047	NUT, PLAIN, HEXAGON .....	8	

END OF FIGURE

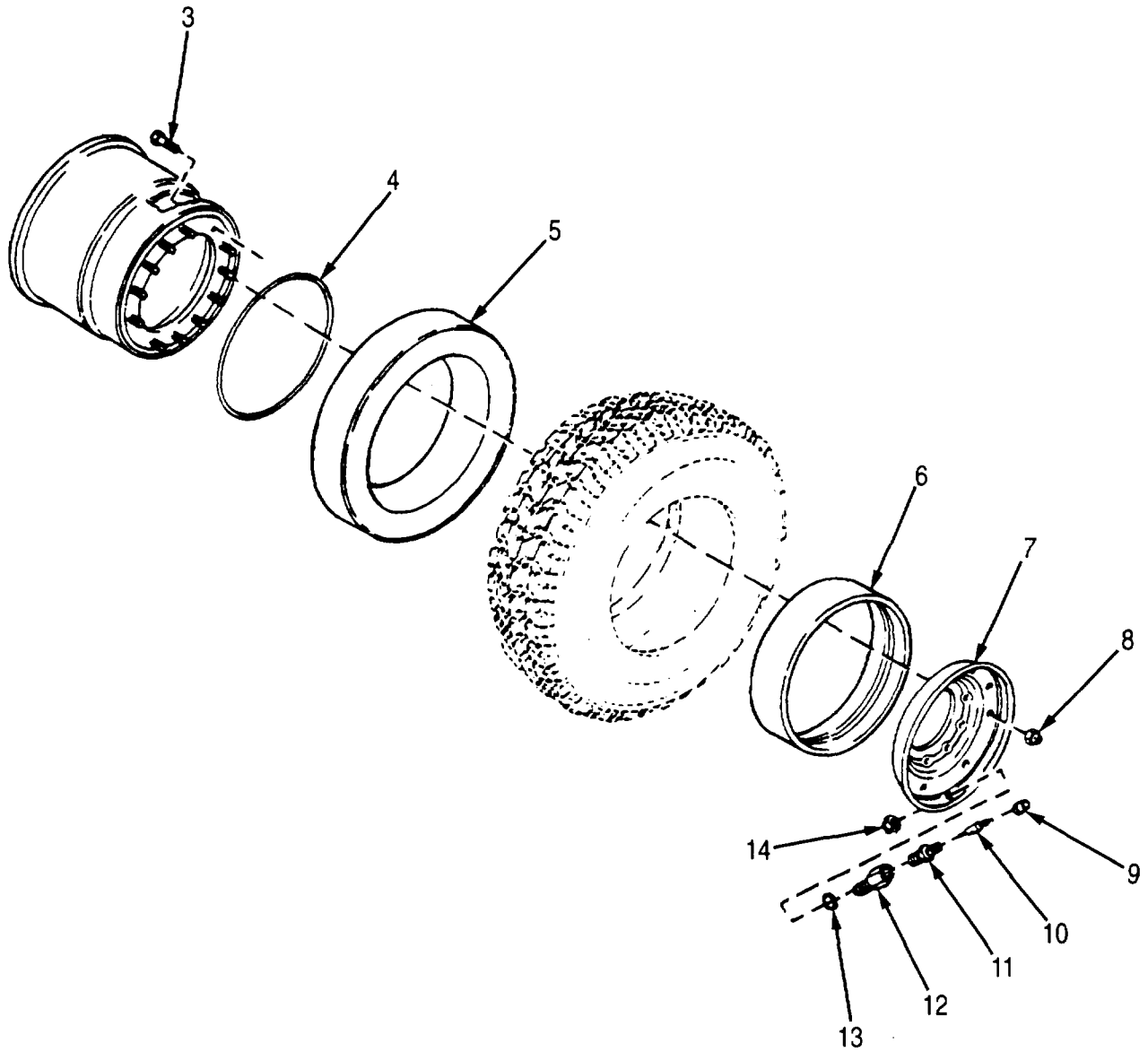
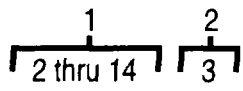


Figure 13. Wheel and Runflat Assembly (M101A3 and M116A3)

(1) ITEM NO	(2) SMR CODE	(3) CAGEC	(4) PART NUMBER	(5) DESCRIPTION AND USABLE ON CODES (UOC)	(6) QTY
SECTION II					
GROUP 1311 WHEEL ASSEMBLY					
FIG. 13 WHEEL AND RUNFLAT ASSEMBLY (M101A3 AND M116A3)					
1	AOOOO		19207 12342641	WHEEL AND RUN FLAT ASSEMBLY RADIAL TIRE .....	1
				UOC:CT1, TC1	
2	PAOOO	2530013365740	19207 12342642	. RIM, WHEEL, PNEUMATIC .....	1
				UOC:CT1, TC1	
3	PAOZZ	5306013367175	19207 12342758	BOLT, RIBBED NECK .....	12
				UOC:CT1, TC1	
4	PAOZZ	5330013358878	19207 12342633	. PACKING, PREFORMED .....	1
				UOC:CT1, TC1	
5	PAOZZ	2640013349453	19207 12342638	. RUNFLAT, INSERT .....	1
				UOC:CT1, TC1	
6	PAOZZ	2530013382730	34623 12342639	. BEADLOCK, TIRE RIM .....	1
				UOC:CT1, TC1	
7	PAOZZ	2530013363127	19207 12342640	. RIM, WHEEL, PNEUMATIC .....	1
				UOC:CT1, TC1	
8	PAOZZ	5310011987585	19207 12339501	. NUT, SELF-LOCKING, HE .....	12
				UOC:CT1, TC1	
9	PAOZZ	2640010982029	81348 TYIV/CL1/TRVC8	. CAP, PNEUMATIC VALVE .....	1
				UOC:CT1, TC1	
10	PAOZZ	2640000501229	81348 TYV/CL2/TR C1	. VALVE CORE .....	1
				UOC:CT1, TC1	
11	PAOZZ	2640013354583	19207 12342634	. VALVE, PNEUMATIC TIR .....	1
				UOC:CT1, TC1	
12	PAOZZ	4730013461063	19207 12342793	. ADAPTER, STRAIGHT, PI .....	1
				UOC:CT1, TC1	
13	PAOZZ	5330013463806	19207 12342794	. PACKING, PREFORMED .....	1
				UOC:CT1, TC1	
14	PAOZZ	5310004492376	96906 MS21245-8	. NUT, SELF-LOCKING, HE .....	1
				UOC:CT1, TC1	

END OF FIGURE

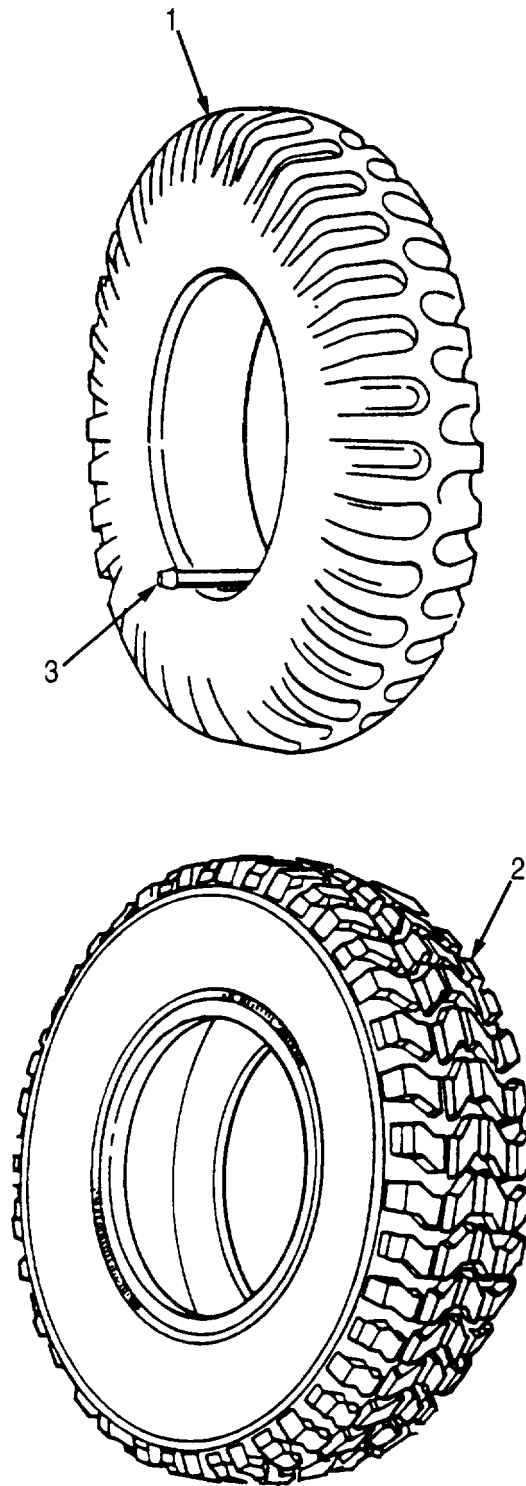


Figure 14. Tire and Valve



SECTION II						TM 9-2330-202-14&P	
(1)	(2)	(3)	(4)	(5)		(6)	
ITEM NO	SMR CODE	CAGEC	PART NUMBER	DESCRIPTION AND USABLE ON CODES (UOC)		QTY	
GROUP 1313 TIRES, TUBES, AND TIRE CHAINS							
FIG. 14 TIRE AND VALVE							
1	PCOFH	2610011481635	12195 03612460	TIRE, PNEUMATIC BIAS PLY .....		1	
				UOC:SPR, 258, 263			
2	PCOFH	2610013337632	19207 12342644	TIRE, PNEUMATIC .....		1	
				UOC:CT1, TC1			
3	PAOZZ	2640005552829	96906 MS51368-2	VALVE, PNEUMATIC TIR .....		1	
				UOC:SPR, 258, 263			
3	PAOZZ	2640013021388	6V625 30-600	VALVE, PNEUMATIC TIR NEW, 0.453 HOLE		1	
				UOC:SPR, 258, 263			

END OF FIGURE

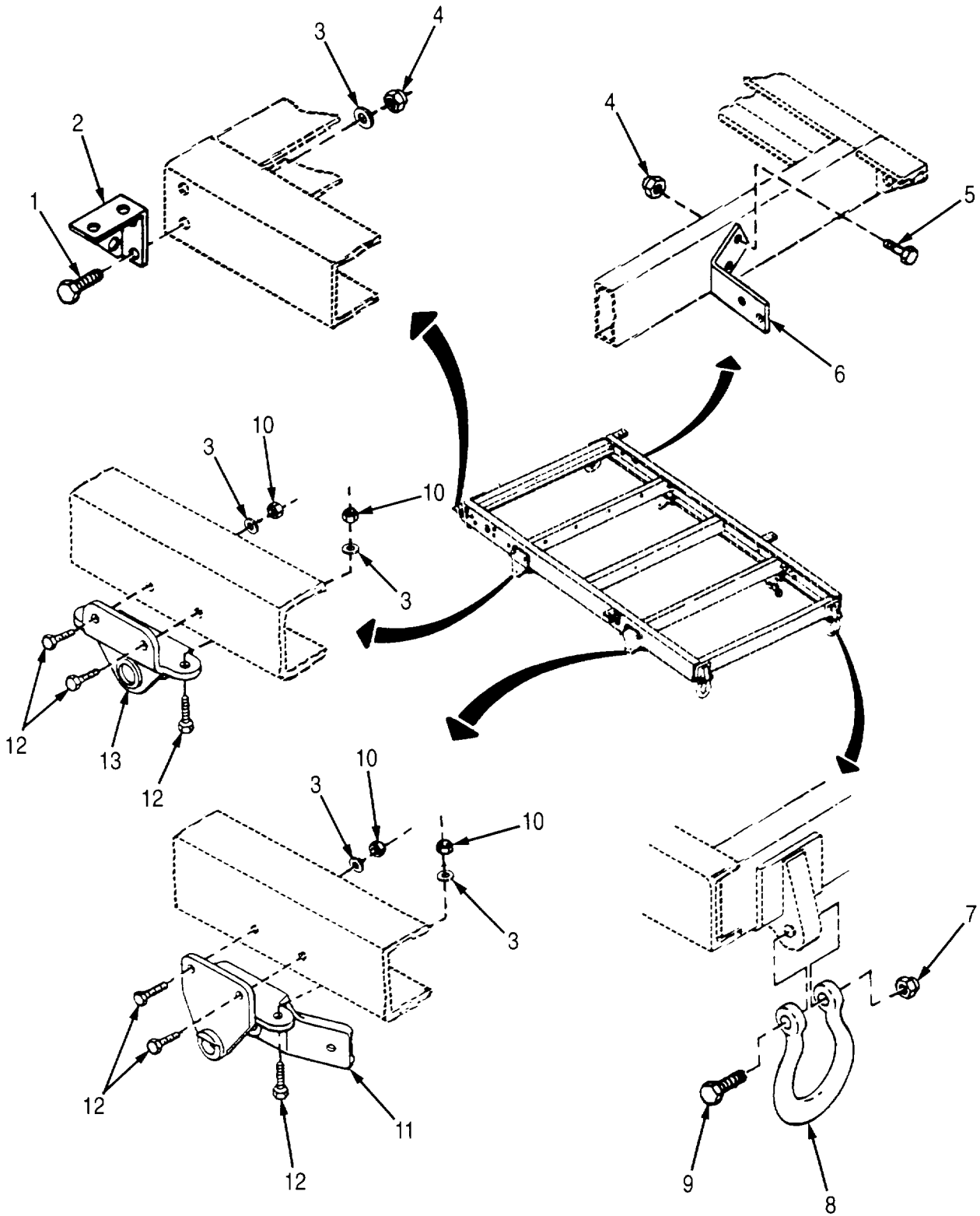


Figure 15. Chassis Frame Assembly

SECTION II						
(1)	(2)	(3)	(4)	(5)	(6)	
ITEM NO	SMR CODE	CAGEC	PART NUMBER	DESCRIPTION AND USABLE ON CODES (UOC)	QTY	
				GROUP 15 FRAME, TOWING ATTACHMENTS, DRAWBARS, AND ARTICULATION SYSTEMS		
				GROUP 1501 FRAME ASSEMBLY		
				FIG. 15 CHASSIS FRAME ASSEMBLY		
1	PAOZZ	5305000680511	80204	B1821BH038C125N SCREW, CAP, HEXAGON H .....	2	
2	PAOZZ	5340007339365	19207	7339365 BRACKET, ANGLE .....	1	
3	PAOZZ	5310008775972	19200	10910174-3 WASHER, FLAT .....	10	
4	PAOZZ	5310000874652	96906	MS51922-17 NUT, SELF-LOCKING, HE .....	4	
5	PAOZZ	5305011409118	80204	B1821BH038C088N SCREW, CAP, HEXAGON H .....	2	
6	PAOZZ	5340000402372	19207	7339489 BRACKET, ANGLE RIGHT .....	1	
6	PAOZZ	5340007339367	19207	7339367 BRACKET, ANGLE LEFT .....	1	
7	PAOZZ	5310000676356	96906	MS51922-57 NUT, SELF-LOCKING, HE .....	1	
				UOC:CT1, SPR, TC1		
8	PAOZZ	4030013719331	19207	12355838 SHACKLE .....	1	
9	PAOZZ	5305009474356	80204	B1821BH075C350N SCREW, CAP, HEXAGON H .....	1	
				UOC:CT1, SPR, TC1		
10	PAOZZ	5310004838789	96906	MS17829-6F NUT, SELF-LOCKING, HE .....	8	
				UOC:CT1, SPR, TC1		
11	PAOZZ	2510007339406	19207	7339406 HANGER, SPRING, VEHIC LEFT .....	1	
11	PAOZZ	5340007058969	19207	7339405 BRACKET, MOUNTING RIGHT .....	1	
12	PAOZZ	5305002693239	80204	B1821BH038F138N SCREW, CAP, HEXAGON H .....	8	
13	PAOZZ	2510007339407	19207	7339407 SHACKLE, LEAF SPRING .....	1	

END OF FIGURE

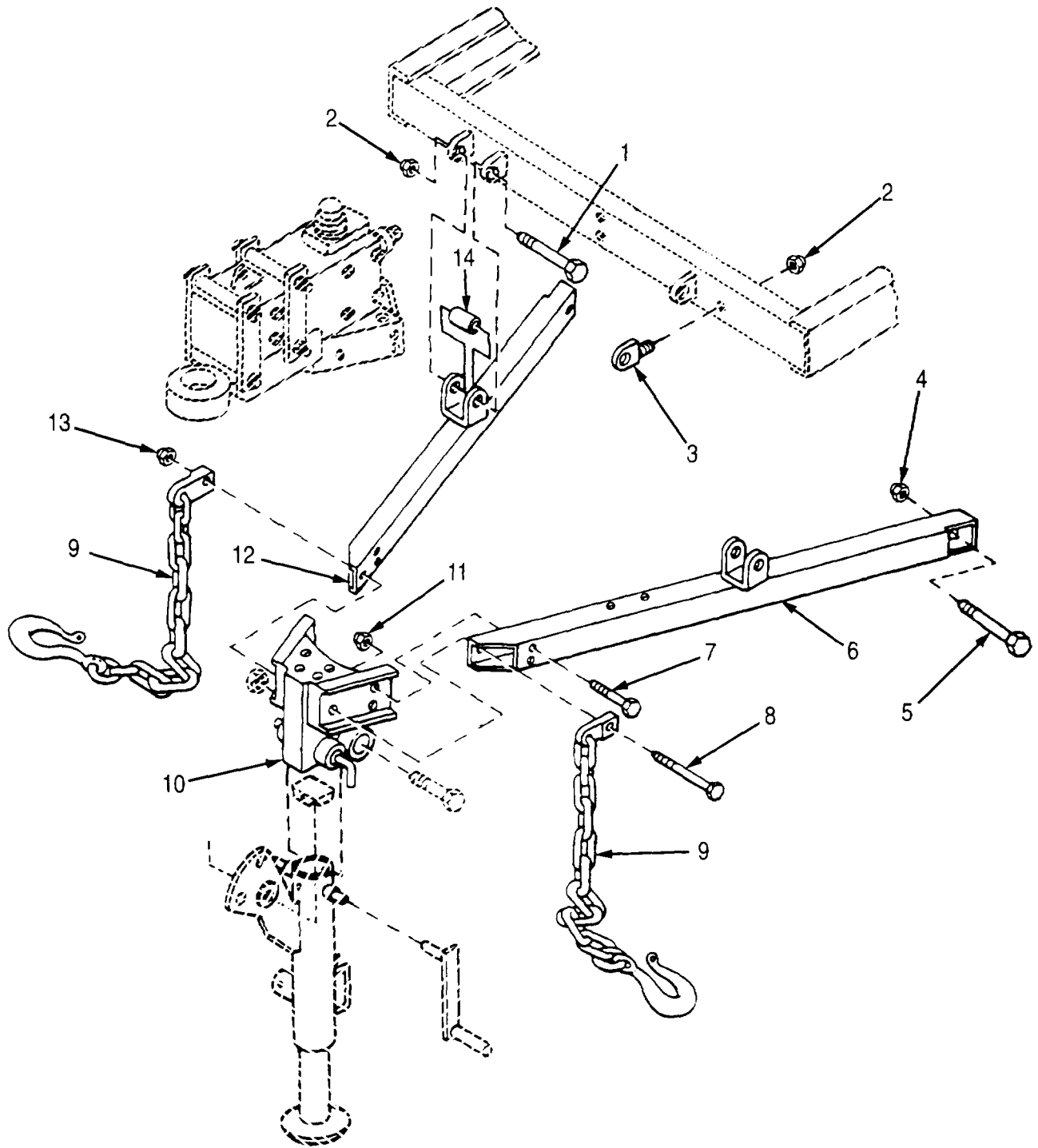


Figure 16. Drawbar Assembly and Safety Chains

## SECTION II

TM9-2330-202-14&amp;P

(1) ITEM NO	(2) SMR CODE	(3) NSN	(4) CAGEC	(5) PART NUMBER	(6) DESCRIPTION AND USABLE ON CODES (UOC) GROUP 1503 PINTLES AND TOWING ATTACHMENTS	(7) QTY
					FIG.16 DRAWBAR ASSEMBLY AND SAFTEY CHAINS (M101A2,M116A2,M116A2E1,AND M116A3)	
1	PAOZZ	5305009456412	96906	MS90727-127	SCREW,CAP,HEXAGON H.....	2
2	PAOZZ	5310008775795	96906	MS21044-N8	NUT,SELF-LOCKING,HE.....	6
3	PAOZZ	5306007337360	19207	7339360	BOLT,EYE.....	4
4	PAOZZ	5310002694040	96906	MS51922-49	NUT,SELF-LOCKING,HE.....	2
5	PAOZZ	5305007245910	96906	MS90725-162	SCREW,CAP,HEXAGON H.....	2
6	PAOZZ		19207	7339474	BAR ASSEMBLY,DRAWBA LEFT HAND..... UOC:258,263	1
6	PBOZZ	2540013697471	19207	10910697	TOWBAR,MOTOR VEHICL DRAWBAR, LEFT HAND..... UOC:CT1,SPR,TC1	1
7	PAOZZ	5305007098515	96906	MS90727-88	SCREW,CAP,HEXAGON H.....	4
8	PAOZZ	5305009589428	96906	MS90727-201	SCREW,CAP,HEXAGON H.....	1
9	PAOZZ	4010007339458	19207	7339458	CHAIN ASSEMBLY,SING.....	2
10	PAOZZ	2540011543892	19207	11675105	BRACKET AND PLUNGER.....	1
11	PAOZZ	5310000577080	96906	MS51922-29	NUT,SELF-LOCKING,HE.....	4
12	PAOZZ	2510000402370	19207	7339475	BAR ASSEMBLY,DRAWBA RIGHT HAND..... UOC:258,263	1
12	PBOZZ		19207	10910698	BRACKET,MOUNTING DRAWBAR, RIGHT HAND..... UOC:CT1,SPR,TC1	1
13	PAOZZ	5310008329719	96906	MS51922-61	NUT,SELF-LOCKING,HE.....	1
14	PAOZZ	5365007339359	02386	7339359	SPACER,SLEEVE.....	2

END OF FIGURE

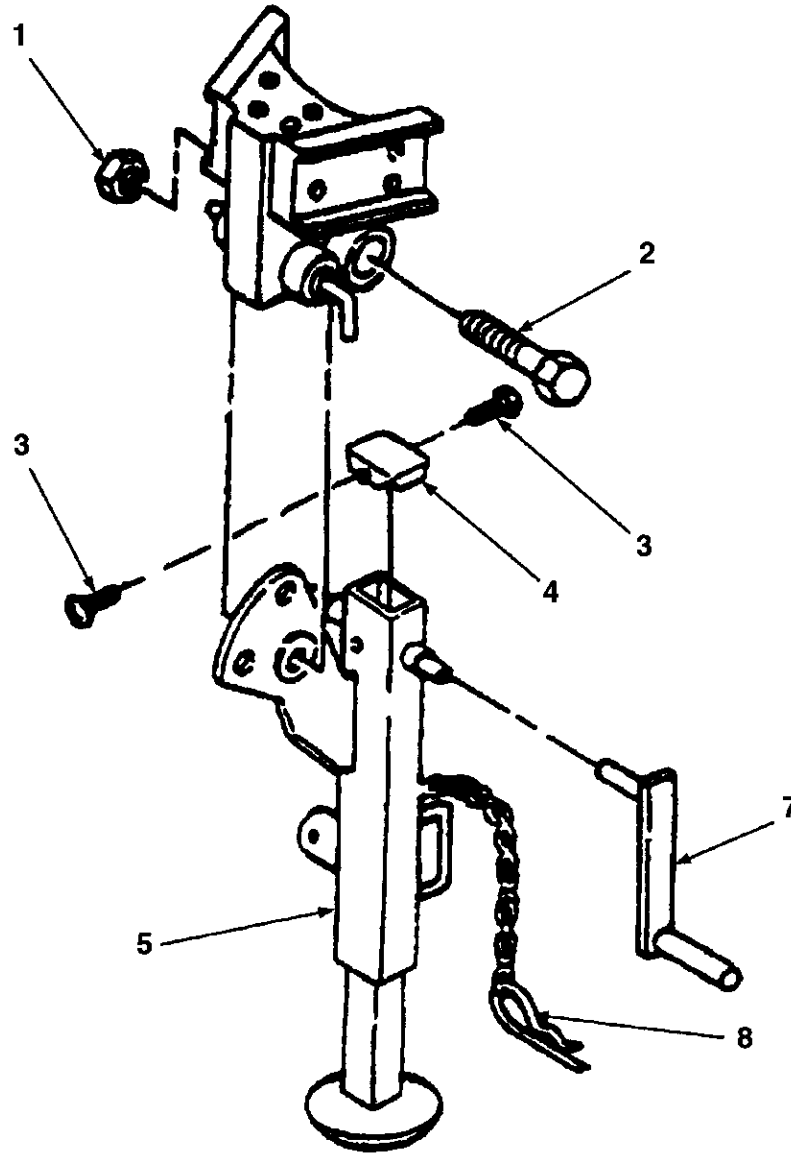


Figure 17. Front Support Leg

## SECTION II

TM9-2330-202-14&amp;P C01

(1) ITEM NO	(2) SMR CODE	(3) NSN	(4) CAGEC	(5) PART NUMBER	(6) DESCRIPTION AND USABLE ON CODES (UOC)	(7) QTY
					GROUP 1507 LANDING GEAR, LEVELING JACKS	
					FIG.17 FRONT SUPPORT LEG	
1	PAOZZ	5310008329719	96906	MS51922-61	NUT, SELF-LOCKING, HE.....	1
2	PAOZZ	5305009472309	80204	B1821BH075F375N	SCREW, CAP, HEXAGON H.....	1
3	PAOZZ	5305007195235	96906	MS90727-114	SCREW, CAP, HEXAGON H.....	2
					UOC:CT1, SPR, 258, 263	
4	PFOZZ		02686	126861	CAP, LANDING JACK.....	1
					UOC:CT1, SPR, TC1	
5	PAOZZ	5120013880958	19207	12436705	JACK, LEVELING-SUPPO.....	1
7	PAOZZ	5340013863974	19207	12441073	HANDLE, BOW.....	1
8	PAOZZ	5315011470855	19207	11602356-2	PIN, LOCK.....	1

END OF FIGURE

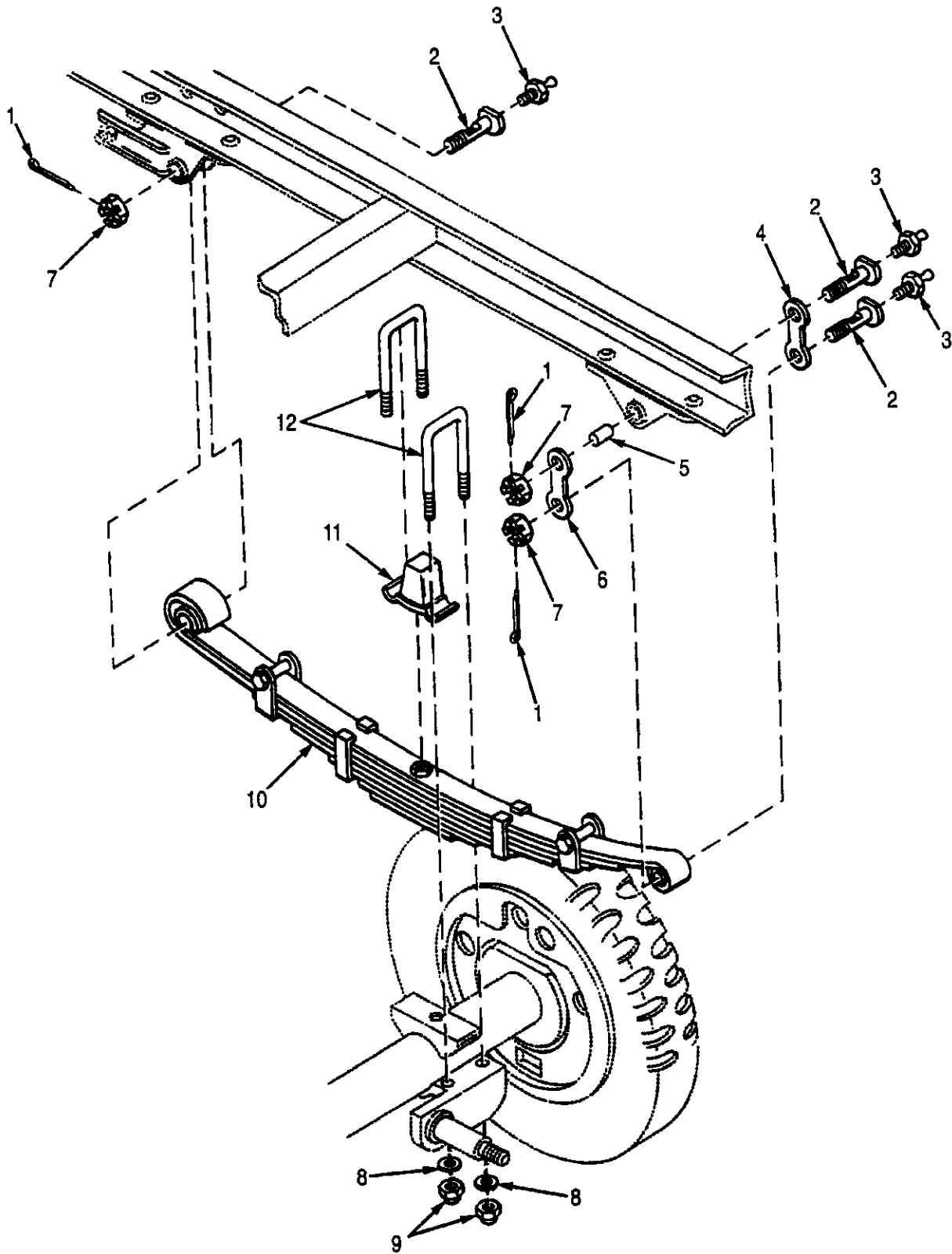


Figure 18. Spring Assembly



(1) ITEM NO	(2) SMR CODE	(3) CAGEC	(4) PART NUMBER	(5) DESCRIPTION AND USABLE ON CODES (UOC)	(6) QTY
SECTION II					
GROUP 16 SPRINGS AND SHOCK ABSORBERS					
GROUP 1601 SPRINGS					
FIG. 18 SPRING ASSEMBLY					
1	PAOZZ	5315002341671	96906 MS24665-633	PIN, COTTER ..... UOC:258, 263	3
1	PAOZZ	5315002981481	96906 MS24665-357	PIN, COTTER ..... UOC:CT1, SPR, TC1	3
2	PAOZZ	2510007410199	19207 7410199	PIN, VEHICULAR LEAF .....	3
3	PAOZZ	4730000504203	96906 MS15001-1	FITTING, LUBRICATION .....	3
4	PAOZZ	2510007339408	19207 7339408	PLATE SHACKLE INNER .....	1
5	PAOZZ	3120008107609	96906 MS35771-91	BEARING, SLEEVE .....	1
6	PAOZZ	2510007058968	19207 7339409	LINK, SPRING SHACKLE .....	1
7	PAOZZ	5310009980608	96906 MS35692-61	NUT, PLAIN, SLOTTED, H .....	3
8	PAOZZ	5310008095998	96906 MS27183-18	WASHER, FLAT ..... UOC:CT1, SPR, TC1	4
9	PAOZZ	5310008775795	96906 MS21044N8	NUT, SELF-LOCKING, HE .....	4
10	PAOZZ	2510011448847	19207 12313029	SPRING ASSEMBLY, LEA 5 LEAVES ..... UOC:258, 263	1
10	PAOZZ	2510013533116	19207 12354240	SPRING ASSEMBLY, LEA 6 LEAVES ..... UOC:CT1, SPR, TC1	1
11	PAOZZ	5340011478290	19207 12313016	BUMPER, NONMETALLIC .....	1
12	PAOZZ	5306011478225	19207 12313028	BOLT, U .....	2

END OF FIGURE

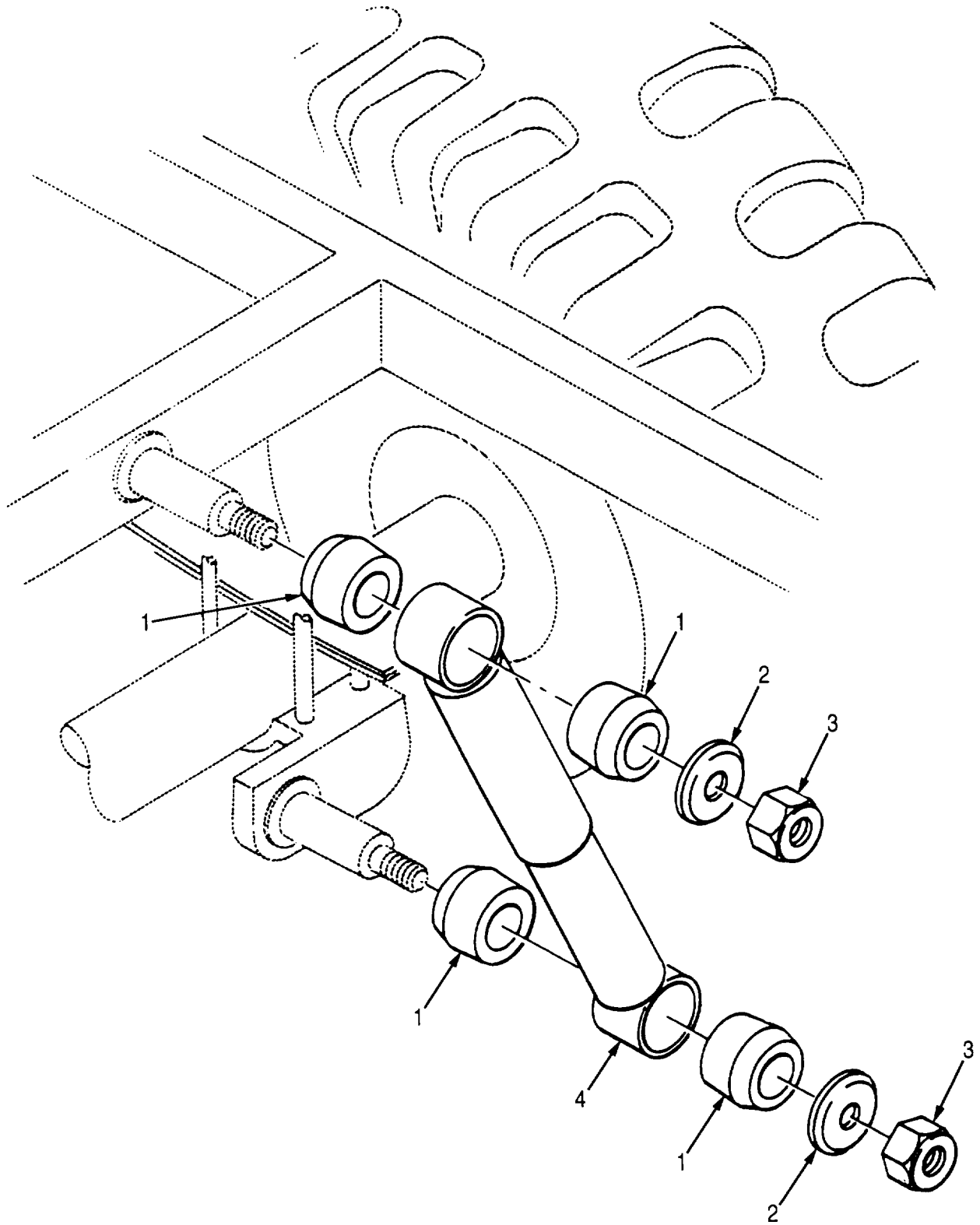


Figure 19. Shock Absorber

SECTION II							
(1)	(2)	(3)	(4)	(5)	(6)		
ITEM	SMR		PART			DESCRIPTION AND USABLE ON CODES (UOC)	QTY
NO	CODE	CAGEC	NUMBER				
						GROUP 1604 SHOCK ABSORBER EQUIPMENT	
						FIG. 19 SHOCK ABSORBER	
1	PAOZZ	5365002754519	19207	7339466		BUSHING, NONMETALLIC .....	4
2	PAOZZ	5310007339465	19207	7339465		WASHER, RECESSED .....	2
3	PAOZZ	5310002256408	96906	MS51922-53		NUT, SELF-LOCKING, HE .....	2
						UOC:CT1, SPR, 263	
4	PAOZZ	2510007339464	19207	7339464		SHOCK ABSORBER, DIRE .....	1

END OF FIGURE

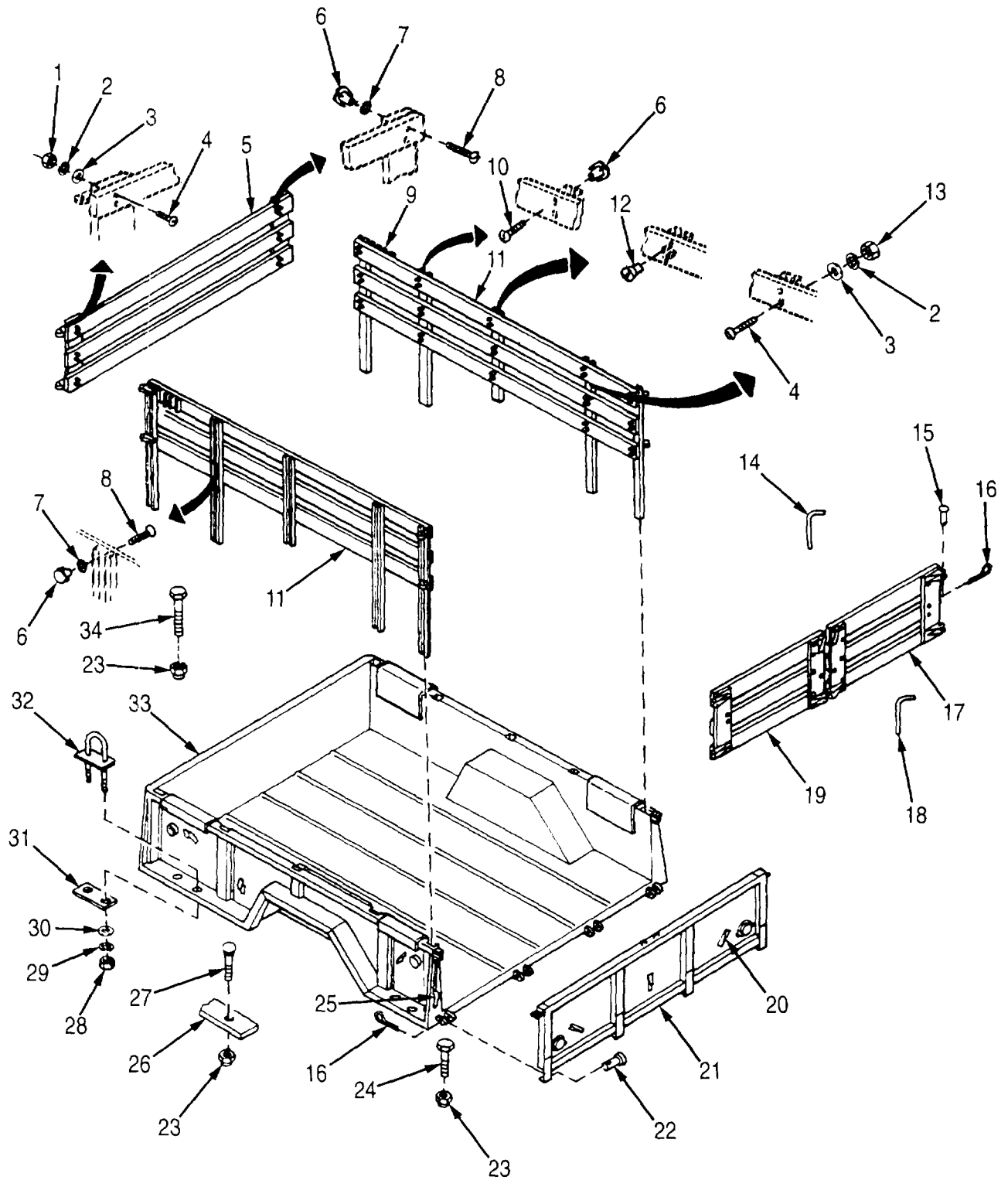


Figure 20. Cargo Body, Rack, and Tailgate Assembly (M101A2 and M101A3)

SECTION II					
(1)	(2)	(3)	(4)	(5)	(6)
ITEM NO	SMR CODE	CAGEC	PART NUMBER	DESCRIPTION AND USABLE ON CODES (UOC)	QTY
				GROUP 18 BODY, CAB, HOOD, AND HULL	
				GROUP 1810 CARGO BODY	
				FIG. 20 CARGO BODY, RACK, AND TAILGATE ASSEMBLY (M101A2 AND M101A3)	
1	PAOZZ	5310009296417	96906 MS24679-65	NUT, PLAIN, CAP ..... UOC:263	34
2	PAOZZ	5310005825965	96906 MS35338-44	WASHER, LOCK ..... UOC:263	74
3	PAOZZ	5310008094058	96906 MS27183-10	WASHER, FLAT ..... UOC:263	74
4	XDOZZ		88044 AN525-416R20	SCREW, MACHINE ..... UOC:TC1, 263	74
5	PAOZZ	2510013890410	19207 12436772S	TAKE, VEHICLE BODY FRONT COMPOSITE UOC:TC1	1
6	PAOZZ	5310000587226	19207 587226	NUT, PLAIN, PLATE USE WITH WOODEN RACKS ..... UOC:263	88
7	PAOZZ	5310005501130	96906 MS35333-40	WASHER, LOCK USE WITH WOODEN RACKS UOC:263	52
8	PAOZZ	5305009881726	96906 MS35206-282	SCREW, MACHINE USE WITH WOODEN RACKS UOC:263	52
9	PFOZZ	2540001778120	19207 7339426	CLIP, BOW VEHICULAR USE WITH WOODEN SIDE RACKS ..... UOC:263	8
9	PFOZZ	5340013889098	19207 12441016	POCKET, STAKE USE WITH COMPOSIT SIDE RACKS ..... UOC:263	8
10	PAOZZ	5305009585246	96906 MS35190-289	SCREW, MACHINE USE WITH WOODEN RACKS UOC:263	36
11	PAOZZ	2510006500998	19207 7339508	SIDE RACK, VEHICLE B SIDE WOODEN ..... UOC:263	1
11	PAOZZ	2510006585859	19207 7339507	SIDE RACK, VEHICLE B LEFT HAND, WOODEN ..... UOC:263	1
11	PAOZZ	2510013890414	19207 12436773	SIDE RACK, VEHICLE B COMPOSITE, REVERSE TOP BOARD FOR L AND R SIDE ..... UOC:TC1, 263	1
12	PAOZZ		88044 AN525-10R9	SCREW MACHINE USE WITH COMPOSITE RACKS ..... UOC:TC1, 263	36
13	PAOZZ	5310000430520	96906 MS35650-3252	NUT, PLAIN, HEXAGON USE WITH COMPOSITE RACKS ..... UOC:TC1, 263	40
14	PBOZZ	3040013171579	19207 7339434	CONNECTING LINK, RIG ..... UOC:263	1
15	PAOZZ	5315007339438	19207 7339438	PIN, STRAIGHT, HEADED ..... UOC:263	8
16	PAOZZ	5315008395822	96906 MS24665-353	PIN, COTTER ..... UOC:263	12

SECTION II						
(1)	(2)	(3)	(4)	(5)	(6)	
ITEM NO	SMR CODE	CAGEC	PART NUMBER	DESCRIPTION AND USABLE ON CODES (UOC)		QTY
17	PAOZZ	510007339505	19207 7339505	SIDE RACK, VEHICLE B RIGHT HAND, WOODEN .....		1
				UOC:263		
18	PBOZZ	3040013171580	19207 7339435	CONNECTING LINK, RIG .....		2
				UOC:263		
19	PAOZZ	2510007339504	19207 7339504	SIDE RACK, VEHICLE B LEFT HAND, WOODEN .....		1
				UOC:263		
20	PAOZZ	4030011718254	19207 7328241	HOOK, CARGO .....		11
				UOC:TC1, 263		
21	PAOZZ	2510011221405	19207 7339510	TAILGATE, VEHICLE BO .....		1
				UOC:263		
22	PAOZZ	5315007339395	19207 7339395	PIN, STRAIGHT, HEADED USE WITH OLD STYLE CARGO BODY .....		4
				UOC:263		
22	PAOZZ	5315010566023	96906 MS20392-7C125	PIN, STRAIGHT, HEADED USE WITH NEW STYLE CARGO BODY .....		4
				UOC:TC1, 263		
23	PAOZZ	5310000874652	96906 MS51922-17	NUT, SELF-LOCKING, HE .....		18
				UOC:263		
24	PAOZZ	5305011409118	80204 B1821BH038C088N	SCREW, CAP, HEXAGON H .....		5
				UOC:263		
25	PAOZZ	2540011267870	19207 8382970	CHAIN AND PIN ASSEM .....		2
				UOC:263		
26	PAOZZ	5340007339366	19207 7339366	CLAMP, SYNCHRO .....		8
				UOC:263		
27	PAOZZ	5306000885742	96906 MS35751-70	BOLT, SQUARE NECK .....		10
				UOC:263		
28	PAOZZ	5310007320560	96906 MS51968-14	NUT, PLAIN, HEXAGON .....		8
				UOC:263		
29	PAOZZ	5310005845272	96906 MS35338-48	WASHER, LOCK .....		8
				UOC:263		
30	PAOZZ	5310008095998	96906 MS27183-18	WASHER, FLAT .....		8
				UOC:263		
31	PAOZZ		19207 12406440-1	PLATE USE WITH NEW STYLE CARGO BODY .....		4
				UOC:TC1, 263		
32	PAOZZ		19207 12406703	BOLT, U USE WITH NEW STYLE CARGO BOX .....		4
				UOC:TC1, 263		
33	PBOZZ	2510013886424	19207 12436764	BODY, CARGO TRAILER NEW STYLE, WITH TAILGATE .....		1
				UOC:TC1, 263		
34	PAOZZ	5305000680511	80204 B1821BH038C125N	SCREW, CAP, HEXAGON H .....		3
				UOC:TC1, 263		

END OF FIGURE



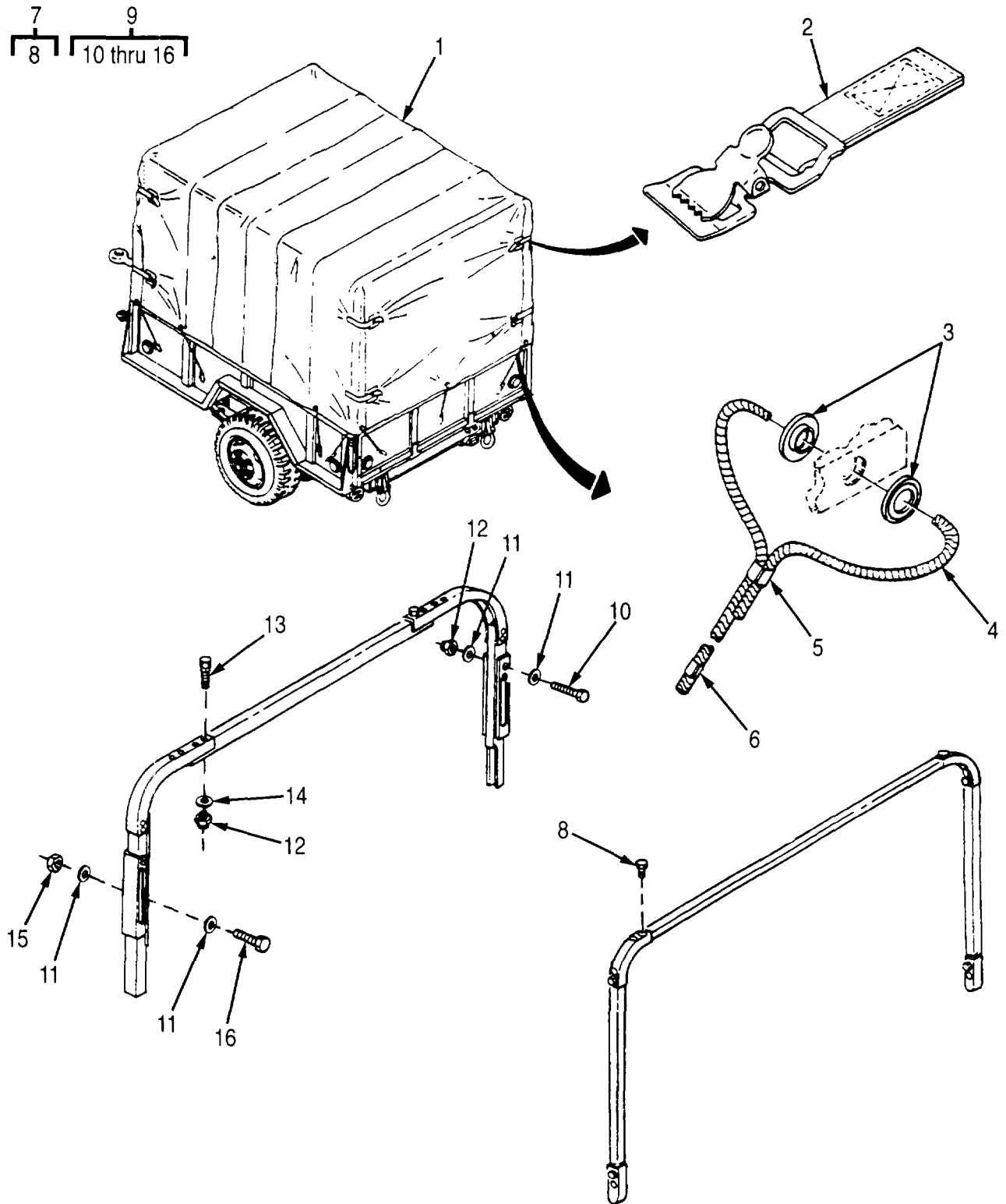


Figure 21. Canvas Cover Assembly and Bows (M101A2 and M101A3)



SECTION II						
(1)	(2)	(3)	(4)	(5)	(6)	
ITEM NO	SMR CODE	CAGEC	PART NUMBER	DESCRIPTION AND USABLE ON CODES (UOC)		QTY
				GROUP 22 BODY, CHASSIS, AND HULL ACCESSORY ITEMS		
				GROUP 2201 CANVAS, RUBBER, OR PLASTIC ITEMS		
				FIG. 21 CANVAS COVER ASSEMBLY AND BOWS (M101A2 AND M101A3)		
1	PAOFF	2540005139794	19207 8382966	COVER, FITTED, VEHICU COLOR: GREEN . UOC:TC1, 263		1
1	PAOFF	2540013257719	19207 8382966-1	COVER, FITTED, VEHICU COLOR: TAN ..... UOC:TC1, 263		1
2	PAOZZ	5340011681534	19207 8710494	STRAP, WEBBING ..... UOC:TC1, 263		1
3	PAOZZ	5325006411612	21450 501437	GROMMET, METALLIC ..... UOC:TC1, 263		1
4	XBOZZ		81348 21-R-162	ROPE (SEE EXPENDABLES) ..... UOC:TC1, 263		1
5	PAOZZ	5340010316310	19207 7979453	CLIP, SPRING TENSION ..... UOC:TC1, 263		1
6	PAOZZ	5340010316268	19207 7979452	CLIP, END, STRAP ..... UOC:TC1, 263		1
7	PAOZZ	2540002786560	19207 7339506	BOW, VEHICULAR TOP WOODEN ..... UOC:263		1
8	PAOZZ	5305009845681	96906 MS35206-301	. SCREW, MACHINE USE WITH WOODEN BOWS UOC:263		8
9	PAOOO	2540016930744	19207 12441082-1	BOW, VEHICULAR TOP STEEL, GREEN ..... UOC:263		1
9	PAOOO		19207 12441082-2	BOW, VEHICULAR TOP STEEL, TAN ..... UOC:263		1
10	PAOZZ	5305000712512	80204 B1821BH025C225N	. SCREW, CAP, HEXAGON H USE WITH STEEL BOWS ..... UOC:TC1, 263		2
11	PAOZZ		96906 MS51412-26	. WASHER, FLAT ..... UOC:263		4
12	PAOZZ	5310000881251	96906 MS51922-1	. NUT, SELF-LOCKING, HE ..... UOC:263		6
13	PAOZZ	5305002678959	80204 B1821BH025F225N	. SCREW, CAP, HEXAGON H ..... UOC:263		2
14	PAOZZ		96906 MS51412-26	. WASHER, FLAT USE WITH STEEL BOWS UOC:263		8
15	PAOZZ	5310013884494	96906 MS51473-01	. NUT, PLAIN, HEXAGON ..... UOC:263		2
16	PAOZZ	5306007026344	96906 MS35751-15	. BOLT, SQUARE NECK ..... UOC:263		4

END OF FIGURE

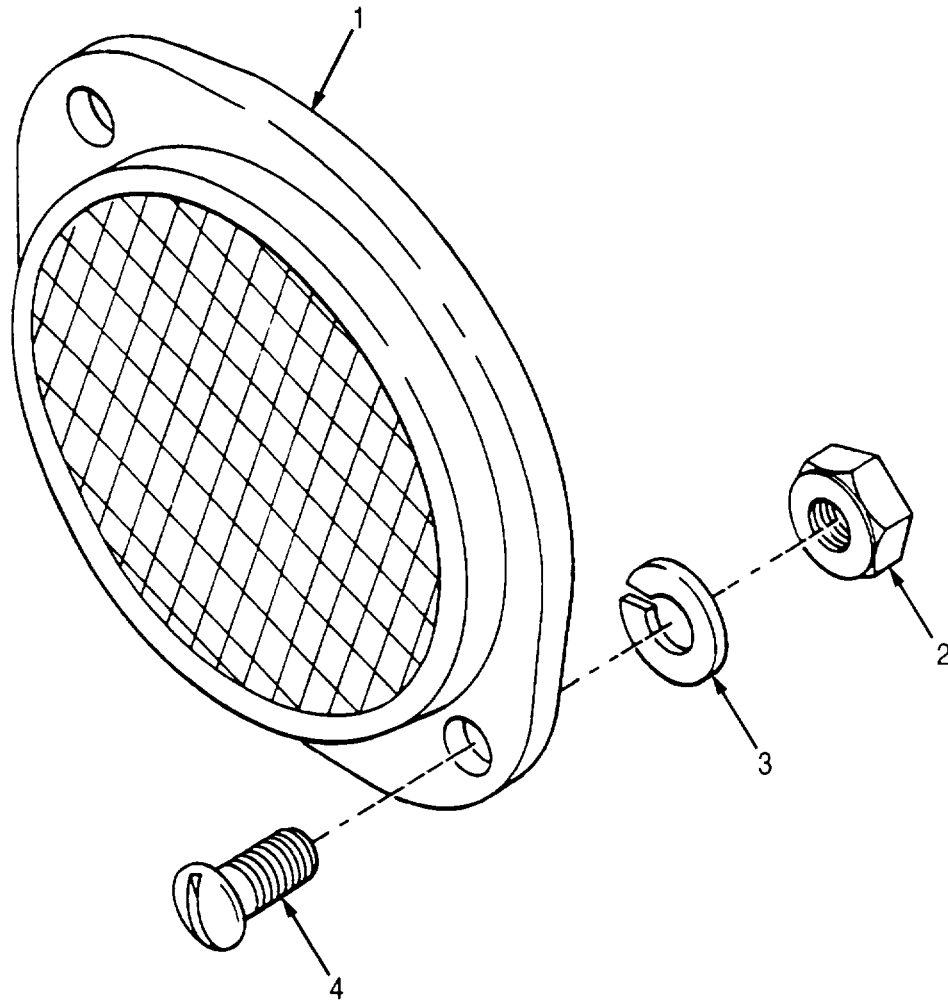


Figure 22. Reflector (M101A2 and M101A3)

SECTION II					
(1)	(2)	(3)	(4)	(5)	(6)
ITEM NO	SMR CODE	CAGEC	PART NUMBER	DESCRIPTION AND USABLE ON CODES (UOC)	QTY
GROUP 2202 ACCESSORY ITEMS					
FIG. 22 REFLECTOR (M101A2 AND M101A3)					
1	PAOZZ	9905002023639	96906 MS35387-2	REFLECTOR, INDICATIN AMBER .....	1
1	PAOZZ	9905002052795	96906 MS35387-1	REFLECTOR, INDICATIN RED .....	1
2	PAOZZ	5310007234458	96906 MS35690-404	NUT, PLAIN, HEXAGON USE WITH OLD STYLE CARGO BODY .....	2
2	PAOZZ	5310007616882	96906 MS51967-2	NUT, PLAIN, HEXAGON USE WITH NEW CARGO BODY .....	2
3	PAOZZ	5310005825965	96906 MS35338-44	UOC:TC1, 263 WASHER, LOCK .....	2
4	PAOZZ	5305009881728	96906 MS35206-287	SCREW, MACHINE USE WITH OLD STYLE CARGO BODY .....	2
4	PAOZZ	5305009881723	96906 MS35206-279	SCREW, MACHINE USE WITH NEW STYLE CARGO BODY .....	2
				UOC:TC1, 263	

END OF FIGURE



## SECTION II

TM9-2330-202-14&amp;P

(1) ITEM NO QTY	(2) SMR CODE	(3) NSN	(4) CAGEC	(5) PART NUMBER	(6) DESCRIPTION AND USABLE ON CODES (UOC)	(7)
					GROUP 2210 DATA PLATES AND INSTRUCTION HOLDERS	
					FIG.23 DATA PLATES	
1	PFOZZ	9905011475836	19207	12296614	PLATE, IDENTIFICATIO DATA..... UOC:258,263	1
1	PFOZZ	9905011475837	19207	12296615	PLATE, IDENTIFICATIO DATA..... UOC:263	1
1	PFOZZ		19207	12362799	PLATE IDENTIFICATIO DATA..... UOC:CT1	1
1	PFOZZ		19207	12441068	PLATE, IDENTIFICATIO DATA..... UOC:TC1	1
1	PFOZZ	9905013603614	19207	12355895	PLATE, IDENTIFICATIO DATA..... UOC:SPR	1
2	PAOZZ		19207	12362800	PLATE, IDENTIFICATIO TRANSPORTATION. UOC:CT1	1
2	PFOZZ		19207	12436756	PLATE, IDENTIFICATIO TRANSPORTATION. UOC:263	1
2	PAOZZ		19207	12362754	PLATE, IDENTIFICATIO DATA..... UOC:SPR, TC1	1
2	PFOZZ	9905013542362	19207	12355904	PLATE, INSTRUCTION TRANSPORTATION... UOC:SPR	1
3	PFOZZ	7690011112265	19207	12302516	DECAL CAUTION, SILICONE BRAKE FLUID	1
4	PAOZZ	5305009512437	96906	MS21318-35	SCREW, DRIVE.....	6

END OF FIGURE

SECTION II

TM 9-2330-202-14&P C01

1  
2 thru 15

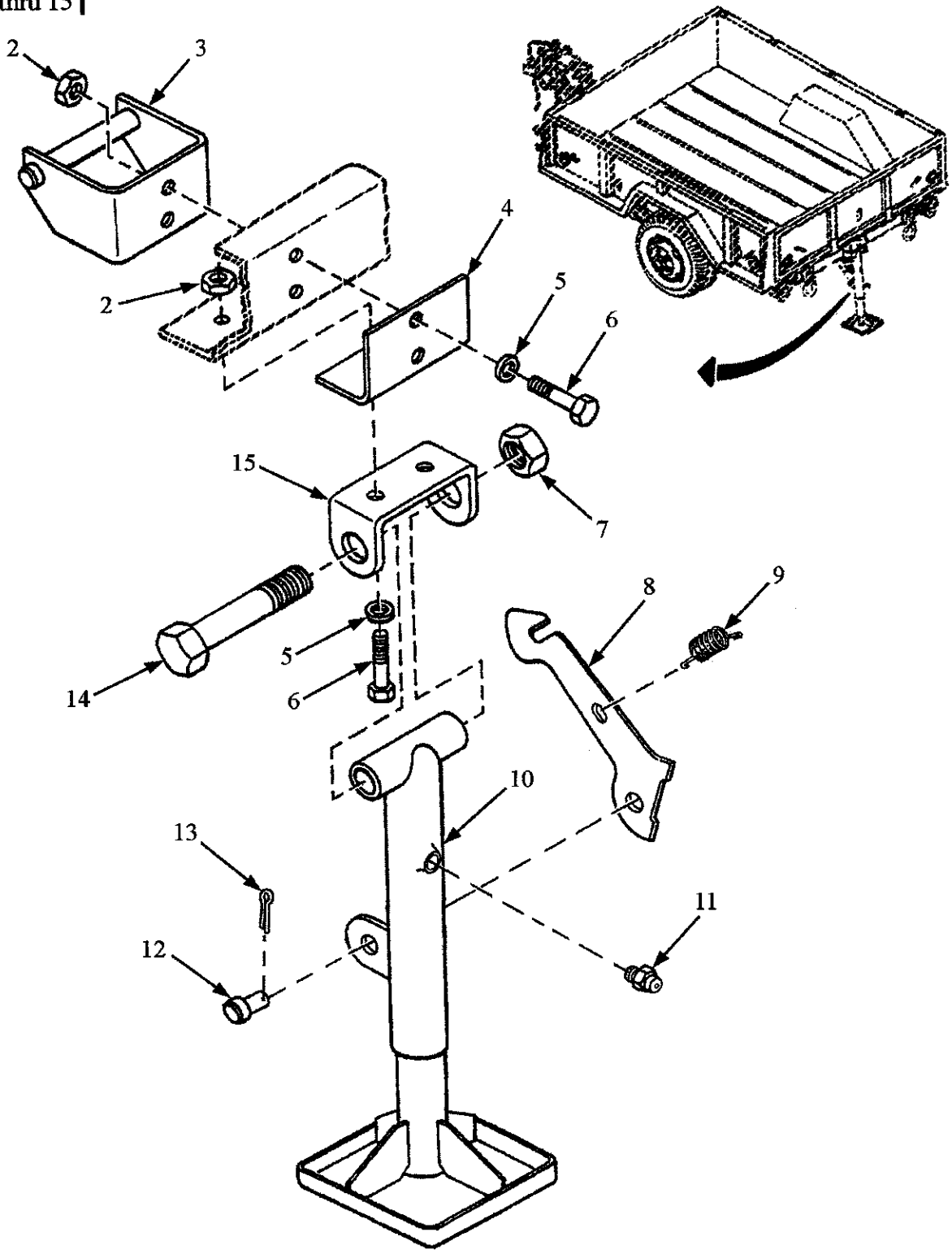


Figure 24. Rear Stabilizer Kit

SECTION II			TM9-2330-202-14&P C01			
(1)	(2)	(3)	(4)	(5)	(6)	(7)
ITEM	SMR			PART		
NO	CODE	NSN	CAGEC	NUMBER	DESCRIPTION AND USABLE ON CODES (UOC)	QTY
					GROUP 33 SPECIAL PURPOSE KITS	
					GROUP 3307 SPECIAL PURPOSE KITS	
					FIG.24 REAR STABILIZER KIT	
1	PAOZZ	2590011799080	19207	10944400	STABILIZER KIT,REAR REQUIRED FOR GENERATOR SETS ONLY.....	1
2	PAOZZ	5310007320559	96906	MS51968-8	.NUT,PLAIN,HEXAGON.....	4
3	PAOZZ	5340011808610	19207	10944402	.BRACKET,DOUBLE ANGL.....	1
4	PFOZZ	5340011955919	19207	10944399	.BRACKET,ANGLE.....	1
5	PAOZZ	5310006379541	96046	20-14-5	.WASHER,LOCK.....	4
6	PAOZZ	5305002693238	96906	MS90727-62	.SCREW,CAP,HEXAGON H.....	4
7	PAOZZ	5310002256408	96906	MS51922-53	.NUT,SELF-LOCKING,HE.....	1
8	XAOZZ		19207	8681938	.ARM ASSEMBLY,STABAL.....	1
9	PAOZZ	5360008868064	19207	8681937	.SPRING,HELICAL,EXTE.....	1
10	PAOZZ	2590004396288	19207	10916389	.JACK,LEVELING-SUPPO.....	1
11	PAOZZ	4730000504203	96906	MS15001-1	.FITTING,LUBRICATION.....	1
12	PAOZZ	5315009042800	96906	MS20392-7C27	.PIN,STRAIGHT,HEADED.....	1
13	PAOZZ	5315008395822	96906	MS24665-353	.PIN,COTTER.....	1
14	PAOZZ	5306008832619	19207	8681932	.BOLT,SHOULDER.....	1
15	PAOZZ	3040001778056	19207	8681933	.BRACKET,EYE,NONROTA.....	1

END OF FIGURE





## SECTION II

TM9-2330-202-14&amp;P C01

(1)	(2)	(3)	(4)	(5)	(6)	(7)
ITEM	SMR			PART		
NO	CODE	NSN	CAGEC	NUMBER	DESCRIPTION AND USABLE ON CODES (UOC)	QTY
					GROUP 95 GENERAL USE STANDARDIZED PARTS	
					GROUP 9501 BULK MATERIEL	
					FIG. BULK	
1	PAOZZ	4710001020108	19207	10943231	TUBE,BENT,METALLIC..... UOC:SPR,258,263	V
2	PAOZZ	4710002000298	81349	M3520-B80A00G	TUBE,METALLIC.....	V

END OF FIGURE



## SECTION IV

TM9-2330-202-14&amp;P CO1

CROSS-REFERENCE INDEXES  
NATIONAL STOCK NUMBER INDEX

STOCK NUMBER	IG.	ITEM	STOCK NUMBER	FIG.	ITEM
5310-00-003-4094	10	16	5310-00-225-6408	24	7
5315-00-013-7238	12	3	5306-00-225-9096	7	5
6240-00-019-0877	1	9	5306-00-226-4822	9	4
6240-00-019-3093	1	12	5315-00-234-1671	18	1
5342-00-040-2364	2	2	5315-00-236-8368	12	3
5340-00-040-2365	2	6	5305-00-267-8953	11	12
2510-00-040-2370	16	12	5305-00-267-8959	21	11
5340-00-040-2372	15	6	5305-00-269-2811	7	6
5310-00-043-0520	20	9	5305-00-269-3234	4	14
5310-00-044-6477	21	9	5305-00-269-3236	8	3
	21	12	5305-00-269-3238	24	6
6240-00-044-6914	1	11	5305-00-269-3239	15	12
5310-00-045-3296	2	5	5310-00-269-4040	16	4
	4	8	5365-00-275-4519	19	1
2640-00-050-1229	13	10	5310-00-275-6635	10	9
4730-00-050-4203	18	3	4730-00-278-8853	11	4
	24	11	5340-00-282-7515	4	9
5310-00-057-7080	10	15	5310-00-285-7037	2	5
	16	11	5330-00-291-6658	10	35
5310-00-061-1258	1	4	5315-00-298-1481	18	1
5310-00-067-6356	15	7	5360-00-384-0004	8	15
5305-00-068-0511	15	1	5360-00-384-0025	8	11
	20	30	5310-00-395-2948	4	2
5305-00-071-2512	21	8	5305-00-432-4203	4	4
5975-00-074-2072	4	5	2590-00-439-6288	24	10
5310-00-074-2328	10	19	5310-00-449-2376	13	14
5310-00-087-4652	15	4	5331-00-462-0907	1	3
	20	19	5365-00-475-8291	7	2
5310-00-088-1251	21	10	5310-00-483-8789	15	10
5306-00-088-5742	20	23	4720-00-489-5350	10	33
3110-00-100-5303	12	9	4710-00-511-1692	10	31
4710-00-102-0108	BULK	1	2540-00-513-9794	21	1
5310-00-134-4141	11	3	5310-00-514-6674	9	3
	11	6	2640-00-555-2829	14	3
	11	18	5310-00-582-5965	11	25
	11	24		20	2
6240-00-143-3159	1	12		22	3
5310-00-143-6102	11	11	5310-00-584-5272	20	25
6240-00-155-8717	1	9	2530-00-585-6079	9	5
2530-00-161-7575	9	1	6240-00-617-0991	1	11
2530-00-161-7576	9	1	5310-00-637-9541	1	5
5340-00-177-7832	4	11		4	13
3040-00-177-8056	24	15		8	5
5325-00-185-0001	4	6		24	5
4710-00-200-0298	BULK	2	5325-00-641-1612	21	3
9905-00-202-3639	22	1	2540-00-693-0744	21	7
9905-00-205-2795	22	1	5306-00-702-6344	21	14
5310-00-209-1761	10	11	2510-00-705-8968	18	6
5305-00-225-3843	11	19	5340-00-705-8969	15	11
5310-00-225-6408	19	3	5305-00-709-8423	10	7

CROSS-REFERENCE INDEXES  
NATIONAL STOCK NUMBER INDEX

STOCK NUMBER	FIG.	ITEM	STOCK NUMBER	FIG.	ITEM
5305-00-709-8515	16	7	5340-00-860-0555	4	15
5305-00-709-8542	10	30	5325-00-864-2993	11	14
5305-00-710-4205	10	6	3040-00-872-8567	8	7
5305-00-719-5209	10	13	5310-00-874-2922	8	8
5305-00-719-5235	17	3	5360-00-877-2964	8	14
5310-00-723-4458	22	2	5310-00-877-5795	10	2
5305-00-724-5910	16	5		16	2
5310-00-732-0559	8	6		18	9
	24	2	5310-00-877-5972	15	3
5310-00-732-0560	10	17	5305-00-881-3824	2	4
	20	24	5306-00-883-2619	24	14
5306-00-733-7360	16	3	5360-00-886-8064	24	9
5365-00-733-9359	16	14	5315-00-904-2800	24	12
5340-00-733-9365	15	2	5310-00-929-6417	20	1
5340-00-733-9366	20	22	5310-00-934-9758	2	7
5340-00-733-9367	15	6		4	10
5315-00-733-9395	20	18	5340-00-936-5284	7	7
2510-00-733-9406	15	11	5305-00-945-6412	16	1
2510-00-733-9407	15	13	5305-00-947-4356	15	9
2510-00-733-9408	18	4	5305-00-949-6184	10	29
5315-00-733-9438	20	11	5305-00-951-2437	23	4
4010-00-733-9458	16	9	5305-00-958-0605	7	4
2510-00-733-9464	19	4	5305-00-958-5258	12	13
5310-00-733-9465	19	2	5305-00-958-9428	16	8
2510-00-733-9504	20	15	5310-00-959-1488	10	14
5330-00-737-3354	10	38	5305-00-984-6210	2	4
2510-00-741-0199	18	2		4	7
5310-00-761-6882	22	2	5305-00-988-1723	22	4
4730-00-773-2163	10	39	5305-00-988-1728	22	4
5340-00-778-2738	11	8	5340-00-993-6207	11	13
5310-00-807-1469	7	1	5310-00-998-0608	18	7
5310-00-809-4058	11	20	5340-01-031-6268	21	6
	20	3	5340-01-031-6310	21	5
5310-00-809-5998	18	8	4730-01-043-3055	11	21
	20	26	5330-01-044-1941	11	26
5310-00-810-1786	7	9	2510-01-050-7136	10	28
3120-00-810-7609	18	5	2530-01-050-7698	10	22
5310-00-816-6352	12	5	5310-01-050-8832	10	20
	12	6	2530-01-050-8929	10	34
6150-00-830-6672	3	1	2540-01-051-6354	10	5
5310-00-832-9719	16	13	2540-01-051-6355	10	3
	17	1	3120-01-052-1151	10	4
2590-00-832-9976	2	2	5365-01-053-6898	10	8
5315-00-839-5822	20	12	4730-01-053-8468	10	12
	24	13	5360-01-054-2281	10	21
5305-00-855-0957	4	1	5315-01-056-6023	20	18
5305-00-855-0958	11	9	2540-01-060-7031	10	18
	11	9	5340-01-068-6693	8	16
5305-00-855-0964	11	15	5340-01-069-6705	8	7
5340-00-860-0555	2	2	5340-01-070-4475	7	3

## CROSS-REFERENCE INDEXES

NATIONAL STOCK NUMBER INDEX					
STOCK NUMBER	FIG.	ITEM	STOCK NUMBER	FIG.	ITEM
2530-01-070-9494	8	13	4720-01-306-6294	11	10
5340-01-071-2098	8	4	3040-01-317-1579	20	10
5120-01-074-9323	8	9	3040-01-317-1580	20	14
5315-01-079-1494	8	2	2540-01-325-7719	21	1
1005-01-083-9297	8	18	2610-01-333-7632	14	2
5360-01-088-0552	8	17	2640-01-334-9453	13	5
2640-01-098-2029	13	9	2640-01-335-4583	13	11
7690-01-111-2265	23	3	5331-01-335-8878	13	4
2510-01-122-1405	20	17	2530-01-336-3127	13	7
2540-01-126-7870	20	21	2530-01-336-5740	13	2
5340-01-132-1175	4	12	5306-01-336-7175	13	3
2530-01-138-9385	5	1	2530-01-338-2730	13	6
5310-01-139-2070	7	8	4730-01-346-1063	13	12
3040-01-139-9900	12	11	5331-01-346-3806	13	13
5330-01-140-8231	12	8	5340-01-348-2989	10	1
5305-01-140-9118	1	6	2510-01-353-3116	18	10
	15	5	9905-01-354-2362	23	2
	20	20	6220-01-359-2870	1	2
2510-01-144-8847	18	10	9905-01-360-3614	23	1
5315-01-147-0855	17	7	2540-01-369-7471	16	6
9905-01-147-5836	23	1	4030-01-371-9331	15	8
9905-01-147-5837	23	1	6220-01-372-3883	1	1
5306-01-147-8225	18	12	5340-01-385-9852	10	24
5340-01-147-8290	18	11	5340-01-386-3974	17	8
2610-01-148-1635	14	1	5120-01-388-0958	17	5
2530-01-148-7074	12	12	5310-01-388-4494	21	13
5310-01-149-0868	12	14	2510-01-388-6424	20	29
3040-01-149-5061	12	2	5340-01-388-9098	20	6
2540-01-154-3892	16	10	2510-01-389-0410	20	5
2530-01-154-6952	12	1		20	5
4010-01-158-6795	10	23	2510-01-389-0414	20	7
2530-01-160-0850	9	2	2530-01-390-4684	5	2
3110-01-165-4860	12	7	2530-01-429-8346	6	1
6150-01-167-1827	2	1	2530-01-430-7250	8	12
2530-01-167-1999	10	27			
5340-01-168-1534	21	2			
2530-01-168-7906	6	1			
5975-01-170-3480	4	16			
4030-01-171-8254	20	16			
2590-01-179-9080	24	1			
5340-01-180-8610	24	3			
5340-01-195-5919	24	4			
5310-01-198-7585	13	8			
2530-01-216-9259	8	10			
5306-01-237-6844	12	10			
6220-01-284-2709	1	10			
2530-01-287-6869	8	1			
6220-01-293-2627	1	8			
6220-01-297-3217	1	8			
2640-01-302-1388	14	3			

## SECTION IV

TM9-2330-202-14&amp;P CO1

CROSS-REFERENCE INDEXES  
PART NUMBER INDEX

CAGEC	PART NUMBER	STOCK NUMBER	FIG.	ITEM
88044	AN525-10R9		20	8
88044	AN525-416R20		20	4
80204	B1821BH025C100N	5305-00-225-3843	11	19
80204	B1821BH025C225N	5305-00-071-2512	21	8
80204	B1821BH025F225N	5305-00-267-8959	21	11
80204	B1821BH031C050N	5306-00-226-4822	9	4
80204	B1821BH038C088N	5305-01-140-9118	1	6
			15	5
			20	20
80204	B1821BH038C125N	5305-00-068-0511	15	1
			20	30
80204	B1821BH038F138N	5305-00-269-3239	15	12
80204	B1821BH075C350N	5305-00-947-4356	15	9
80204	B1821BH075F375N		17	2
63477	F6019	5330-00-291-6658	10	35
96906	MS122031	5310-00-285-7037	2	5
96906	MS15001-1	4730-00-050-4203	18	3
			24	11
96906	MS15570-1251	6240-00-019-0877	1	9
96906	MS15570-623	6240-00-019-3093	1	12
96906	MS15570-89	6240-00-143-3159	1	12
96906	MS17829-6F	5310-00-483-8789	15	10
96906	MS20392-7C125	5315-01-056-6023	20	18
96906	MS20392-7C27	5315-00-904-2800	24	12
96906	MS21042-5	5310-00-807-1469	7	1
96906	MS21042-6	5310-00-810-1786	7	9
96906	MS21044-N8	5310-00-877-5795	16	2
96906	MS21044N8	5310-00-877-5795	10	2
			18	9
96906	MS21083-C7	5310-00-074-2328	10	19
96906	MS21245-8	5310-00-449-2376	13	14
96906	MS21318-35	5305-00-951-2437	23	4
96906	MS21333-2	5340-00-778-2738	11	8
96906	MS21333-37	5340-00-282-7515	4	9
96906	MS21333-99	5340-00-993-6207	11	13
96906	MS24629-45	5305-00-855-0958	11	9
			11	9
96906	MS24629-46	5305-00-855-0957	4	1
96906	MS24629-48	5305-00-855-0964	11	15
96906	MS24665-353	5315-00-839-5822	20	12
			24	13
96906	MS24665-357	5315-00-298-1481	18	1
96906	MS24665-425	5315-00-013-7238	12	3
96906	MS24665-436	5315-00-236-8368	12	3
96906	MS24665-633	5315-00-234-1671	18	1
96906	MS24679-65	5310-00-929-6417	20	1
96906	MS27111-10	5310-00-816-6352	12	5
			12	6
96906	MS27183-10	5310-00-809-4058	11	20
			20	3
96906	MS27183-18	5310-00-809-5998	18	8

## SECTION IV

TM9-2330-202-14&amp;P CO1

## CROSS-REFERENCE INDEXES

CAGEC	PART NUMBER	PART NUMBER INDEX		FIG.	ITEM
			STOCK NUMBER		
96906	MS27183-18		5310-00-809-5998	20	26
96906	MS3367-1-9		5975-00-074-2072	4	5
96906	MS35190-317		5305-00-958-5258	12	13
96906	MS35206-263		5305-00-984-6210	2	4
				4	7
96906	MS35206-279		5305-00-988-1723	22	4
96906	MS35206-287		5305-00-988-1728	22	4
96906	MS35207-298		5305-00-958-0605	7	4
96906	MS35335-34		5310-00-514-6674	9	3
96906	MS35338-43		5310-00-045-3296	2	5
				4	8
96906	MS35338-44		5310-00-582-5965	11	25
				20	2
				22	3
96906	MS35338-46		5310-00-637-9541	1	5
				4	13
				8	5
96906	MS35338-48		5310-00-584-5272	20	25
96906	MS35387-1		9905-00-205-2795	22	1
96906	MS35387-2		9905-00-202-3639	22	1
96906	MS35478-1073		6240-00-617-0991	1	11
96906	MS35478-1683		6240-00-044-6914	1	11
96906	MS35489-46		5325-00-185-0001	4	6
96906	MS35649-202		5310-00-934-9758	2	7
				4	10
96906	MS35650-3252		5310-00-043-0520	20	9
96906	MS35690-404		5310-00-723-4458	22	2
96906	MS35692-61		5310-00-998-0608	18	7
96906	MS35751-15		5306-00-702-6344	21	14
96906	MS35751-70		5306-00-088-5742	20	23
96906	MS35771-91		3120-00-810-7609	18	5
96906	MS35845-11			10	32
96906	MS45904-64		5310-00-395-2948	4	2
96906	MS45904-76		5310-00-061-1258	1	4
96906	MS51368-2		2640-00-555-2829	14	3
96906	MS51412-25		5310-00-044-6477	21	9
				21	12
96906	MS51473-01		5310-01-388-4494	21	13
96906	MS51861-47		5305-00-432-4203	4	4
96906	MS51922-1		5310-00-088-1251	21	10
96906	MS51922-17		5310-00-087-4652	15	4
				20	19
96906	MS51922-21		5310-00-959-1488	10	14
96906	MS51922-29		5310-00-057-7080	10	15
				16	11
96906	MS51922-49		5310-00-269-4040	16	4
96906	MS51922-53		5310-00-225-6408	19	3
				24	7
96906	MS51922-57		5310-00-067-6356	15	7
96906	MS51922-6		5310-00-143-6102	11	11
96906	MS51922-61		5310-00-832-9719	16	13

## CROSS-REFERENCE INDEXES

CAGEC	PART NUMBER	PART NUMBER INDEX		FIG.	ITEM
			STOCK NUMBER		
96906	MS51922-61		5310-00-832-9719	17	1
96906	MS51967-2		5310-00-761-6882	22	2
96906	MS51968-14		5310-00-732-0560	10	17
				20	24
96906	MS51968-8		5310-00-732-0559	8	6
				24	2
96906	MS51975-2		5305-00-949-6184	10	29
96906	MS521301A204R		4720-00-489-5350	10	33
96906	MS90725-162		5305-00-724-5910	16	5
96906	MS90726-41		5306-00-225-9096	7	5
96906	MS90726-67		5305-00-269-2811	7	6
96906	MS90726-99		5305-00-710-4205	10	6
96906	MS90727-110		5305-00-719-5209	10	13
96906	MS90727-114		5305-00-719-5235	17	3
96906	MS90727-127		5305-00-945-6412	16	1
96906	MS90727-201		5305-00-958-9428	16	8
96906	MS90727-5		5305-00-267-8953	11	12
96906	MS90727-58		5305-00-269-3234	4	14
96906	MS90727-60		5305-00-269-3236	8	3
96906	MS90727-62		5305-00-269-3238	24	6
96906	MS90727-88		5305-00-709-8515	16	7
96906	MS90727-91		5305-00-709-8542	10	30
96906	MS90727-97		5305-00-709-8423	10	7
81349	M3520-B80A00G		4710-00-200-0298	BULK	2
81348	TYIV/CL1/TRVC8		2640-01-098-2029	13	9
81348	TYV/CL2/TR C1		2640-00-050-1229	13	10
81348	W-L-00111/60		6240-00-155-8717	1	9
12195	03612460		2610-01-148-1635	14	1
14892	049206		2530-01-160-0850	9	2
93072	10614		2530-01-050-8929	10	34
93072	10632		2540-01-060-7031	10	18
93072	10703		2530-01-167-1999	10	27
19200	10910174-3		5310-00-877-5972	15	3
19207	10910697		2540-01-369-7471	16	6
19207	10910698			16	12
19207	10916389		2590-00-439-6288	24	10
19207	10924576		5975-01-170-3480	4	16
19207	10926073		5340-00-936-5284	7	7
19207	10926074		5340-01-070-4475	7	3
19207	10926075		5365-00-475-8291	7	2
19207	10926094		5310-01-139-2070	7	8
19207	10943231		4710-00-102-0108	BULK	1
19207	10944399		5340-01-195-5919	24	4
19207	10944400		2590-01-179-9080	24	1
19207	10944402		5340-01-180-8610	24	3
21450	110357		5310-00-134-4141	11	3
				11	6
				11	18
				11	24
19207	11602356-2		5315-01-147-0855	17	7
19207	11625496		4730-01-043-3055	11	21



## CROSS-REFERENCE INDEXES

CAGEC	PART NUMBER	PART NUMBER INDEX		FIG.	ITEM
			STOCK NUMBER		
19207	11625497		5330-01-044-1941	11	26
19207	11639519-2		5331-00-462-0907	1	3
19207	11652180		6150-01-167-1827	2	1
19207	11652180-2			2	1
19207	11675013		5340-01-348-2989	10	1
19207	11675105		2540-01-154-3892	16	10
19207	11686100			11	1
19207	11686100-56.5			11	2
19207	11686101		2530-01-168-7906	6	1
19207	11686102			11	5
19207	11686102-1X			11	7
19207	11686103-1			11	22
19207	11686103-1-1X			11	23
19207	11686103-2			11	16
19207	11686103-2-1X			11	17
19207	11686257		2530-01-070-9494	8	13
19207	11686262-1		5340-01-069-6705	8	7
19207	11686262-2		3040-00-872-8567	8	7
19207	11686267-1		2530-00-161-7576	9	1
19207	11686267-2		2530-00-161-7575	9	1
19207	11686270		5360-00-384-0025	8	11
19207	11686271		1005-01-083-9297	8	18
19207	11686272		5360-00-384-0004	8	15
19207	11686273		5315-01-079-1494	8	2
19207	11686274		5360-01-088-0552	8	17
19207	11686275		5340-01-068-6693	8	16
19207	11686276		5340-01-071-2098	8	4
19207	11686277		2530-00-585-6079	9	5
19207	11686279		5360-00-877-2964	8	14
19207	11686280		5310-00-874-2922	8	8
19207	11686281		5120-01-074-9323	8	9
19204	11838714		2530-01-216-9259	8	10
19207	12296386		4010-01-158-6795	10	23
19207	12296614		9905-01-147-5836	23	1
19207	12296615		9905-01-147-5837	23	1
19207	12302516		7690-01-111-2265	23	3
19207	12313006		2530-01-138-9385	5	1
19207	12313010		3040-01-139-9900	12	11
19207	12313012		2530-01-148-7074	12	12
19207	12313016		5340-01-147-8290	18	11
19207	12313027		5330-01-140-8231	12	8
19207	12313028		5306-01-147-8225	18	12
19207	12313029		2510-01-144-8847	18	10
19207	12313045		3110-01-165-4860	12	7
19207	12313046		3110-00-100-5303	12	9
19207	12313047		5310-01-149-0868	12	14
19207	12313048		3040-01-149-5061	12	2
19207	12314088			10	25
19207	12331722		5340-01-385-9852	10	24
19207	12338799			14	2
19207	12339501		5310-01-198-7585	13	8

## CROSS-REFERENCE INDEXES

CAGEC	PART NUMBER	PART NUMBER INDEX		FIG.	ITEM
			STOCK NUMBER		
19207	12342633		5331-01-335-8878	13	4
19207	12342634		2640-01-335-4583	13	11
19207	12342638		2640-01-334-9453	13	5
34623	12342639		2530-01-338-2730	13	6
19207	12342640		2530-01-336-3127	13	7
19207	12342641			13	1
19207	12342642		2530-01-336-5740	13	2
19207	12342644		2610-01-333-7632	14	2
19207	12342758		5306-01-336-7175	13	3
19207	12342793		4730-01-346-1063	13	12
19207	12342794		5331-01-346-3806	13	13
19207	12354199		4720-01-306-6294	11	10
19207	12354223		5306-01-237-6844	12	10
19207	12354224			11	1
19207	12354224-1			11	2
19207	12354225			11	5
19207	12354225-1			11	7
19207	12354240		2510-01-353-3116	18	10
19207	12355838		4030-01-371-9331	15	8
19207	12355895		9905-01-360-3614	23	1
19207	12355904		9905-01-354-2362	23	2
19207	12356020			10	26
19207	12360850-1		6220-01-284-2709	1	10
19207	12360870-1		6220-01-293-2627	1	8
19207	12360870-2		6220-01-297-3217	1	8
19207	12362746			10	10
19207	12362754			23	2
19207	12362791		2530-01-390-4684	5	2
19207	12362795			11	16
19207	12362795-1			11	17
19207	12362796			11	22
19207	12362796-1			11	23
19207	12362799			23	1
19207	12362800			23	2
19207	12375837		6220-01-372-3883	1	1
19207	12375838			1	7
19207	12375841		6220-01-359-2870	1	2
19207	12406440-1			20	27
19207	12406703			20	28
19207	12436705		5120-01-388-0958	17	5
19207	12436756			23	2
19207	12436764		2510-01-388-6424	20	29
19207	12436764-1			20	29
19207	12436772		2510-01-389-0410	20	5
				20	5
19207	12436773		2510-01-389-0414	20	7
19207	12440462		2510-00-733-9504	20	15
19207	12440463			20	13
19207	12441016		5340-01-388-9098	20	6
19207	12441068			23	1
19207	12441073		5340-01-386-3974	17	8

## CROSS-REFERENCE INDEXES

CAGEC	PART NUMBER INDEX		FIG.	ITEM
	PART NUMBER	STOCK NUMBER		
19207	12441077		2	3
19207	12441082-1	2540-00-693-0744	21	7
19207	12441093		12	4
19207	12448059	2530-01-430-7250	8	12
02686	126861		17	4
02686	126945		10	37
11862	14035374	2530-01-154-6952	12	1
21450	143449	4730-00-278-8853	11	4
92867	15641501	2530-01-429-8346	6	1
19207	171591	5305-00-881-3824	2	4
93072	1745	3120-01-052-1151	10	4
93072	1804	2530-01-050-7698	10	22
93072	1808-1	2540-01-051-6355	10	3
93072	1828	5360-01-054-2281	10	21
93072	1829	2540-01-051-6354	10	5
93072	1840	5310-01-050-8832	10	20
93072	1841	5365-01-053-6898	10	8
93072	1844-2	2510-01-050-7136	10	28
94189	18496	2530-01-287-6869	8	1
96046	20-14-5	5310-00-637-9541	24	5
81348	21-R-162		21	4
01276	210104-8S	5310-00-003-4094	10	16
6V625	30-600	2640-01-302-1388	14	3
21450	501437	5325-00-641-1612	21	3
19207	5160323	5310-00-209-1761	10	11
19207	5214539	5310-00-275-6635	10	9
93072	622794-X		10	36
19207	7328241	4030-01-171-8254	20	16
19207	7336030	5340-01-132-1175	4	12
02386	7339359	5365-00-733-9359	16	14
19207	7339360	5306-00-733-7360	16	3
19207	7339365	5340-00-733-9365	15	2
19207	7339366	5340-00-733-9366	20	22
19207	7339367	5340-00-733-9367	15	6
19207	7339395	5315-00-733-9395	20	18
19207	7339405	5340-00-705-8969	15	11
19207	7339406	2510-00-733-9406	15	11
19207	7339407	2510-00-733-9407	15	13
19207	7339408	2510-00-733-9408	18	4
19207	7339409	2510-00-705-8968	18	6
19207	7339434	3040-01-317-1579	20	10
19207	7339435	3040-01-317-1580	20	14
19207	7339438	5315-00-733-9438	20	11
19207	7339458	4010-00-733-9458	16	9
19207	7339464	2510-00-733-9464	19	4
19207	7339465	5310-00-733-9465	19	2
19207	7339466	5365-00-275-4519	19	1
19207	7339474		16	6
19207	7339475	2510-00-040-2370	16	12
19207	7339489	5340-00-040-2372	15	6
19207	7339510	2510-01-122-1405	20	17

## SECTION IV

TM9-2330-202-14&amp;P CO1

## CROSS-REFERENCE INDEXES

CAGEC	PART NUMBER	PART NUMBER INDEX		FIG.	ITEM
			STOCK NUMBER		
19207	7373354		5330-00-737-3354	10	38
19207	7410199		2510-00-741-0199	18	2
19207	7735289		5325-00-864-2993	11	14
19207	7979250			4	3
19207	7979452		5340-01-031-6268	21	6
19207	7979453		5340-01-031-6310	21	5
63477	7979691		4730-00-773-2163	10	39
19207	8347212		5342-00-040-2364	2	2
19207	8347213		5340-00-040-2365	2	6
19207	8365426		4710-00-511-1692	10	31
19207	8382966		2540-00-513-9794	21	1
19207	8382966-1		2540-01-325-7719	21	1
19207	8382966-2			21	1
19207	8382970		2540-01-126-7870	20	21
19207	8382973		5340-00-177-7832	4	11
19207	8681932		5306-00-883-2619	24	14
19207	8681933		3040-00-177-8056	24	15
19207	8681937		5360-00-886-8064	24	9
19207	8681938			24	8
19207	8710494		5340-01-168-1534	21	2
19207	8722865		6150-00-830-6672	3	1
19207	8722870		5340-00-860-0555	2	2
				4	15
19207	8722943		2590-00-832-9976	2	2
19207	8762000		4730-01-053-8468	10	12

**APPENDIX F  
EXPENDABLE AND DURABLE ITEMS LIST**

**Section I. INTRODUCTION**

Paragraph Number	Paragraph Title	Page Number
F-1	Scope .....	F-1
F-2	Explanation of Columns in Section II .....	F-1

**F-1. SCOPE.**

This appendix lists expendable/durable supplies and materials you will need to operate and maintain the M101 and M116 Series trailers. This listing is for informational purposes only and is not authority to requisition the listed items. These items are authorized to you by CTA 50-970 or CTA 8-100.

**F-2. EXPLANATION OF COLUMNS IN SECTION II.**

There are five columns in Section II, Expendable and Durable Items List:

**Column (1) - Item Number.** This number is assigned to the entry in the listing and is referenced in the "Initial Setup" of maintenance paragraphs or narrative instructions to identify the material needed. For example: "Solvent, drycleaning (Item 15, Appendix F)."

**Column (2) - Level.** This column identifies the lowest level of maintenance that requires the listed item:

- C - Operator/Crew
- O - Unit
- F - Direct Support
- H - General Support

**Column (3) - National Stock Number.** This is the national stock number assigned to the item; use it to request or requisition the item.

**Column (4) - Description (CAGEC).** This column contains the Federal item name and, if required, a description to identify the item. The last line for each item indicates the commercial and government entity code (CAGEC) in parentheses followed by the part number, if applicable.

**Column (5) - U/M (Unit of Measure).** Indicates the measure used in performing the actual maintenance function. This measure is expressed by a two-character alphabetical abbreviation: BD (bundle), BE (bale), CA (cartridge), CN (can), DR (drum), EA (each), FT (foot), GL (gallon), PG (package), PT (pint), QT (quart), and RO (roll). If the unit of measure differs from the unit of issue, requisition the lowest unit of issue that will satisfy your requirements.

## Section II. EXPENDABLE AND DURABLE ITEMS LIST

(1) ITEM NUMBER	(2) LEVEL	(3) NATIONAL STOCK NUMBER	(4) DESCRIPTION  (CAGEC)	(5) UNIT OF MEAS
1	0	7920-00-061-0038	BRUSH: Scrub (81348) H-B-1490	EA
2	0	7920-00-900-3577	BRUSH: Wire (17987) 15SS	EA
3	0	5350-00-192-5051	CLOTH: Abrasive, 180 Grit (58536) A-A1048 50 Each	PG
4	0	5350-00-174-0985	CLOTH: Abrasive, 600 Grit (81348) GGG-C-520 100 Each	BD
5	C	7930-00-282-9699	DETERGENT: General Purpose, Liquid (81349) MIL-D-16791 1-Gallon Can	GL
6	0	9150-01-102-9455 9150-01-123-3152 9150-01-072-8379	FLUID: Brake Silicone, Automotive, All Weather, Operational and Preservative (81349) MIL-B-46176  1-Gallon Can, Plastic 5-Gallon Can 55-Gallon Drum	GL CN DR
7	0	9150-01-197-7693 9150-01-197-7690 9150-01-197-7689 9150-01-197-7692	GREASE: Automotive and Artillery, GAA (81349) MIL-G-10924 E & F  14-Ounce Cartridge 1 3/4 Pound Can 6 1/2 Pound Can 35-Pound Pail	CA CN CN CN
8	0	6640-01-364-1413	JAR: Screw Cap, (15481) 033-670 Package of 12, 32-Ounce Capacity	PG
9	0	2640-01-262-9517	LUBRICANT: Runflat (19207)12339497 2 Packets	PG
			<b>F-2</b>	

Section II. EXPENDABLE AND DURABLE ITEMS LIST

(1) ITEM NUMBER	(2) LEVEL	(3) NATIONAL STOCK NUMBER	(4) DESCRIPTION  (CAGEC)	(5) UNIT OF MEAS
10	0	9150-00-402-4478 9150-00-402-2372 9150-00-491-7197	OIL: Lubricating, Internal Combustion Engine, Arctic, OEA (81349) MIL-L-46167  1-Quart Can 5-Gallon Can 55-Gallon Drum	QT CN DR
11	0	9150-00-189-6727 9150-00-186-6668 9150-00-191-2772	OIL: Lubricating, Internal Combustion Engine, Tactical Service, OE/HDO 10 (81349) MIL-L-2104  1-Quart Can 5-Gallon Can 55-Gallon Drum	QT CN DR
12	0	9150-00-186-6681 9150-00-188-9858 9150-00-189-6729	OIL: Lubricating, Internal Combustion Engine, Tactical Service, OE/HDO 30 (81349) MIL-L-2104  1-Quart Can 5-Gallon Can 55-Gallon Drum	QT CN DR
13	C	7920-00-205-1711	RAG: Wiping, Cotton and Cotton Synthetic, White (58536) A-A-531 50-Pound Bale	BE
14	0		ROPE 3/8-Inch Diameter	RL
15	C	6850-00-110-4498 6850-00-664-5685 6850-00-281-1985 6850-00-274-5421 6850-00-285-8011	SOLVENT: Drycleaning, Type II (81349) P-D-680  1-Pint Can 1-Quart Can 1-Gallon Can 5-Gallon Can 55-Gallon Drum	PT QT GL CN DR
16	0	9905-00-537-8954	TAG: Marker (81349) MIL-T-12755 50 Each  <b>F-3</b>	BD

Section II. EXPENDABLE AND DURABLE ITEMS LIST

(1) ITEM NUMBER	(2) LEVEL	(3) NATIONAL STOCK NUMBER	(4) DESCRIPTION  (CAGEC)	(5) UNIT OF MEAS
17	0	9330-01-345-0507	TAPE: Adhesive, Acrylic (30076) 353191 60-Yard Roll	RO
18	0	5640-00-103-2254	TAPE: Duct, 2 Inches Wide (07124) C-519 60-Yard Roll	RO
19	0	7510-00-802-8311	TAPE: Pressure Sensitive (52170) 898 3/4 Inch Wide, 60-Yard Roll	RO
20	0	4720-01-014-4915	TUBING: Plastic (06853) 246115 8-Inch, Black	FT
<p><b>F-4</b></p>				



**APPENDIX G  
ILLUSTRATED LIST OF MANUFACTURED ITEMS**

**Section I. INTRODUCTION**

Paragraph Number	Paragraph Title	Page Number
G-1	Introduction .....	G-1
Table G-1	Manufactured Items Part Number Index .....	G-1

**G-1. INTRODUCTION.**

- a. This appendix includes complete instructions for making items authorized to be manufactured or fabricated at the Unit level of maintenance.
- b. A part number index in alphanumeric order is provided in Table G-1 for cross-referencing the part number of the item to be manufactured to the figure that covers the fabrication criteria.
- c. All bulk materials needed for the manufacture of an item are listed by part number or specification number in a tabular list on the illustration in Section II.
- d. When manufacturing items, make sure the appropriate tools are used to cut, shape, and thread materials. Make sure hoses are clean and free of dust and moisture before installing after fabrication.
- e. All dimensions given in Section II, Manufacturing Instructions, are in standard units.

*Table G-1. Manufactured Items Part Number Index*

Part Number	Figure Title	Figure Number
RRC271-8	Adjustable Front Support Leg Chain	G-9
11686100	Hydraulic Brake Tube Assembly, Front (M101A2 and M116A2)	G-1
11686102	Hydraulic Brake Tube Assembly, Rear (M101A2 and M116A2)	G-3
11686103-1	Hydraulic Brake Tube Assembly, Left (M101A2, M116A2, and M116A2E1)	G-5
11686103-2	Hydraulic Brake Tube Assembly, Right (M101A2, M116A2, and M116A2E1)	G-5

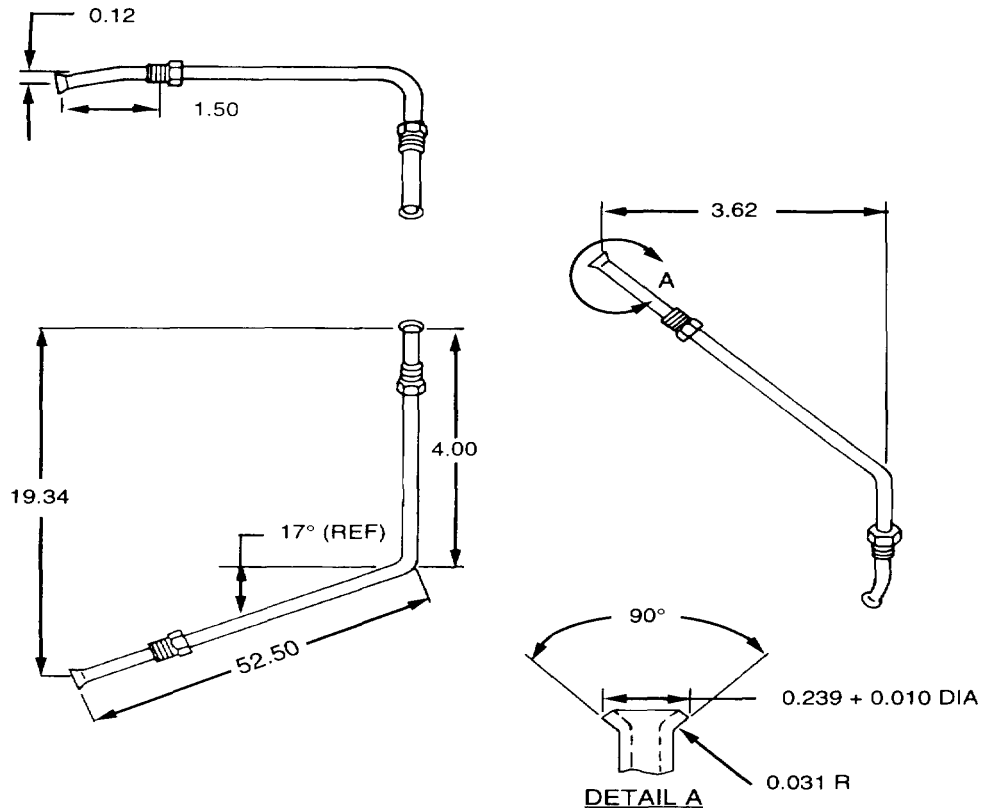
Table G-1. Manufactured Items Part Number Index (continued)

Part Number	Figure Title	Figure Number
12354224	Hydraulic Brake Tube Assembly, Front (M101A3, M116A2E1, and M116A3)	G-2
12354225	Hydraulic Brake Tube Assembly, Rear (M101A3, M116A2E1, and M116A3)	G-4
12362795	Hydraulic Brake Tube Assembly, Right (M101A3 and M1 16A3)	G-7
12362796	Hydraulic Brake Tube Assembly, Left (M101A3 and M116A3)	G-6
7339259	Drawbar Clamp Spacer (M101A2 and M116A2)	G-8

Section II. MANUFACTURING INSTRUCTIONS

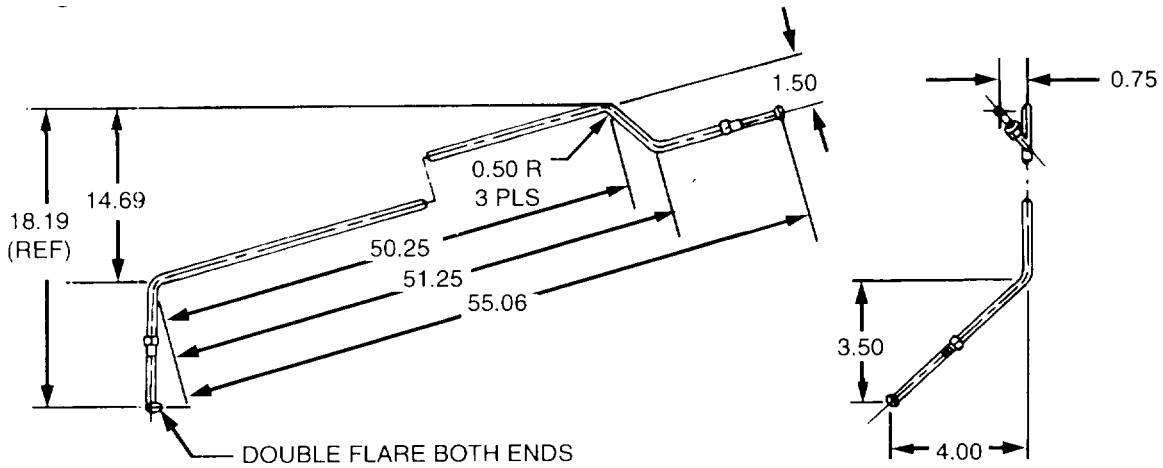
Paragraph Number	Paragraph Title	Page Number
Figure G-1	Hydraulic Brake Tube Assembly, Front (M101A2 and M1 16A2).....	G-3
Figure G-2	Hydraulic Brake Tube Assembly, Front (M101A3, M116A2E1, and M116A3).....	G-4
Figure G-3	Hydraulic Brake Tube Assembly, Rear (M101A2 and M1 16A2).....	G-4
Figure G-4	Hydraulic Brake Tube Assembly, Rear (M101A3, M116A2E1, and M116A3).....	G-5
Figure G-5	Hydraulic Brake Tube Assembly, Left and Right (M101A2, M116A2, and M116A2E1).....	G-6
Figure G-6	Hydraulic Brake Tube Assembly, Left (M101A3 and M116A3).....	G-7
Figure G-7	Hydraulic Brake Tube Assembly, Right (M101A3 and MI 16A3).....	G-8
Figure G-8	Drawbar Clamp Spacer (M101 A2 and M116A2).....	G-9
Figure G-9	Adjustable Front Support Leg Chain.....	G-9

Figure G-1. Hydraulic Brake Tube Assembly, Front (M101A2 and M116A2)



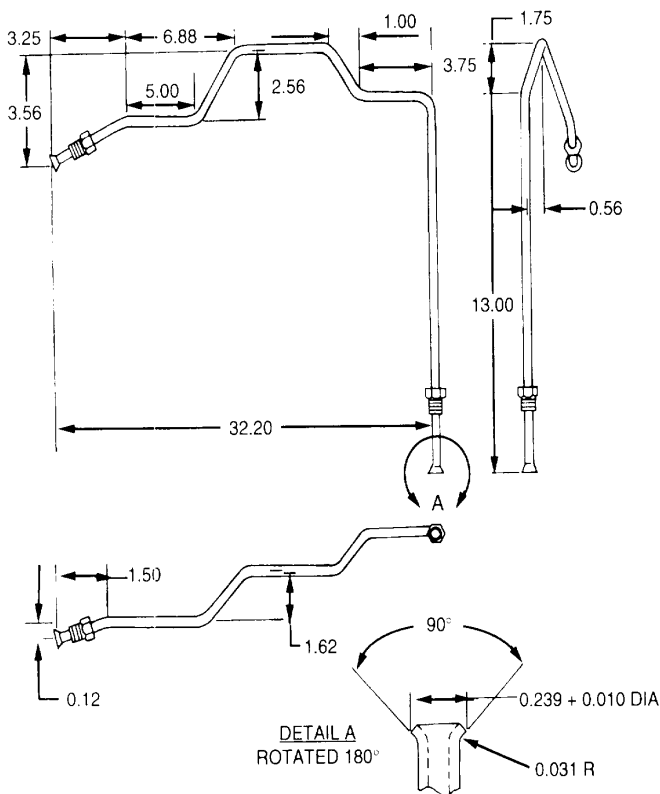
1. Fabricate from tube, part number 10943231, NSN 4710-00-102-0108.
2. Cut to proper length and bend as shown to create part number 11686100-56.5.
3. Install nut, part number 110357, on each end of tube assembly, as shown.

Figure G-2. Hydraulic Brake Tube Assembly, Front (M101A3, M116A2E1, and M116A3)



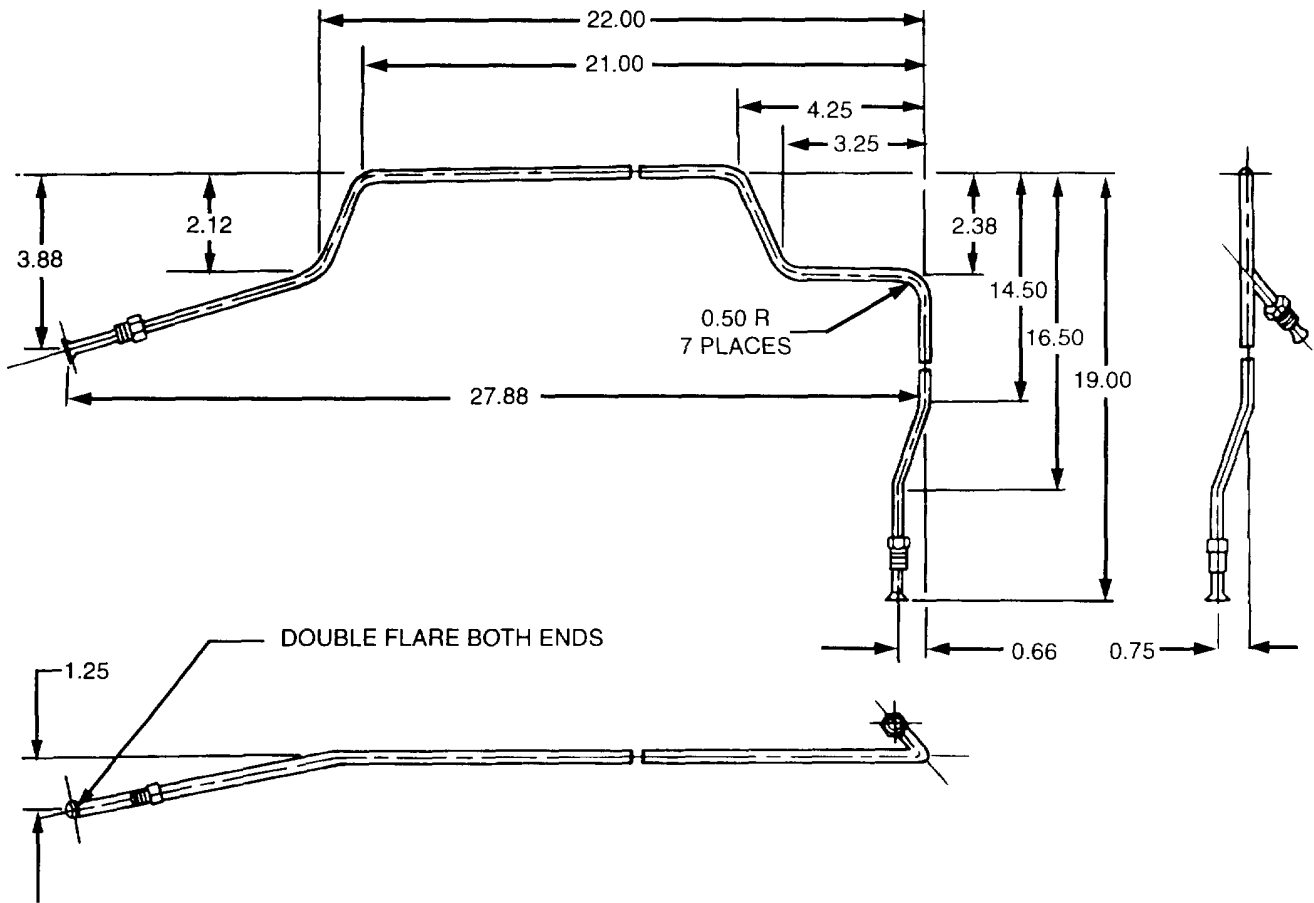
1. Fabricate from tube, part number M3520-B80A00G, NSN 4710-00-200-0298.
2. Cut to proper length and bend as shown to create part number 12354224-1.
3. Install nut, part number 110357, on each end of tube assembly, as shown.

Figure G-3. Hydraulic Brake Tube Assembly, Rear (M101A2 and M116A2)



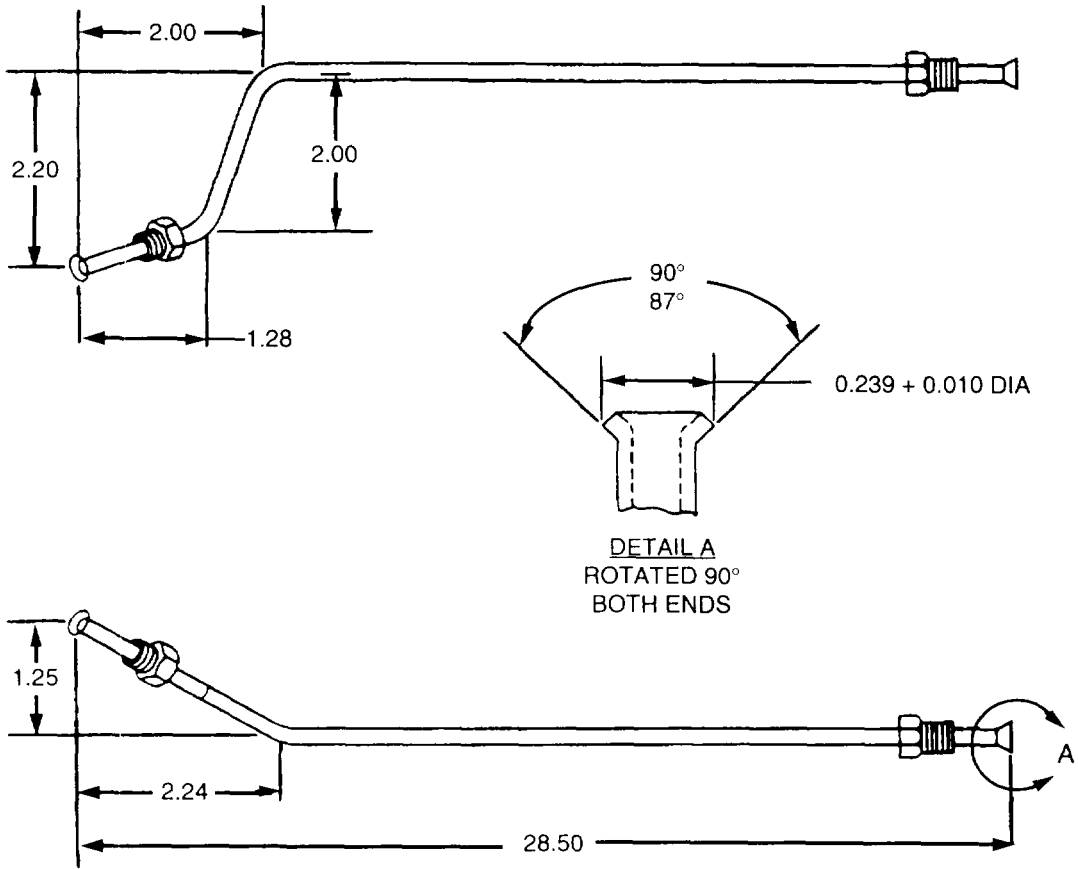
1. Fabricate from tube, part number M3520-B80A00G, NSN 4710-00-200-0298.
2. Cut to proper length and bend as shown to create part number 11686102-1X.
3. Install nut, part number 110357, on each end of tube assembly, as shown.

Figure G-4. Hydraulic Brake Tube Assembly, Rear (M101A3, M116A2E1, and M116A3)



1. Fabricate from tube, part number M3520-B80A00G, NSN 4710-00-200-0298.
2. Cut to proper length and bend as shown to create part number 12354225-1.
3. Install nut, part number 110357, on each end of tube assembly, as shown.

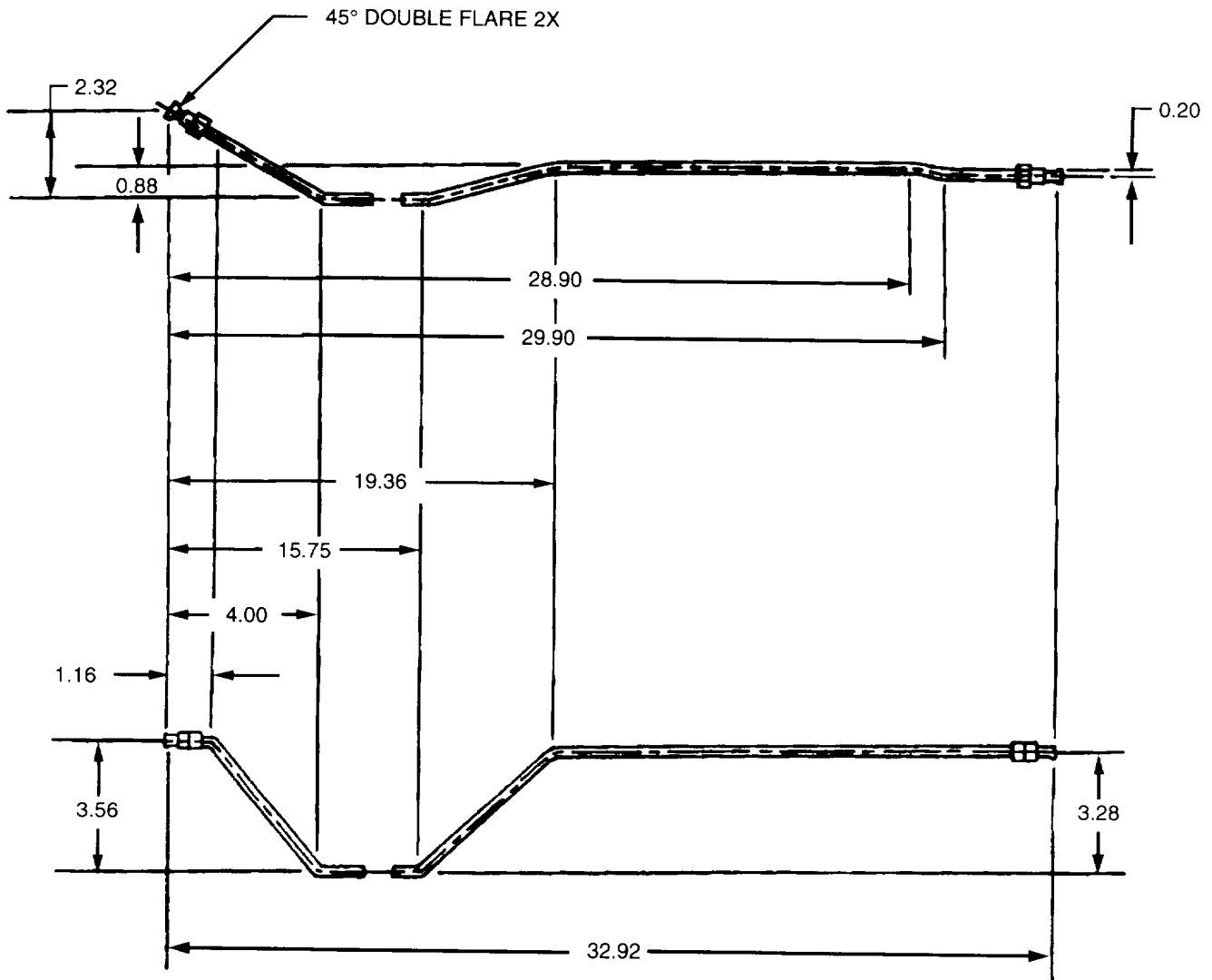
Figure G-5. Hydraulic Brake Tube Assembly, Left and Right (M101A2, M116A2, and M116A2E1)



Part Number	Position
11686103-1	Left Side (As Shown)
11686103-2	Right Side (Opposite of Shown)

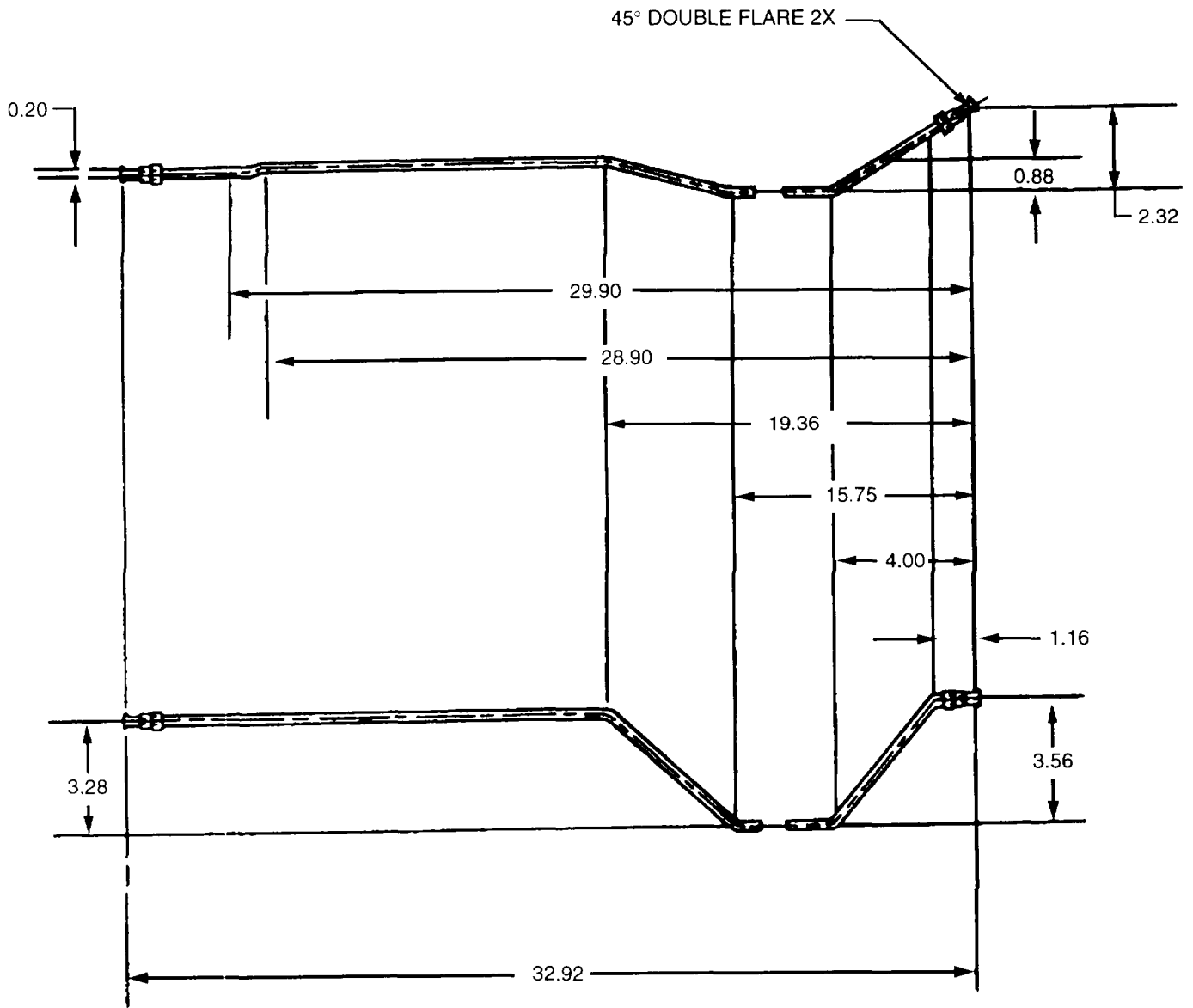
1. Fabricate from tube, part number M3520-B80A00G, NSN 4710-00-200-0298.
2. Cut to proper length and bend as shown.
3. Install nut, part number 110357, on each end of tube assembly, as shown.

Figure G-6. Hydraulic Brake Tube Assembly, Left (M101A3 and M1 16A3)



1. Fabricate from tube, part number M3520-B80A00G, NSN 4710-00-200-0298.
2. Cut to proper length and bend as shown to create part number 12362796-1.
3. Install nut, part number 110357, on each end of tube assembly, as shown.

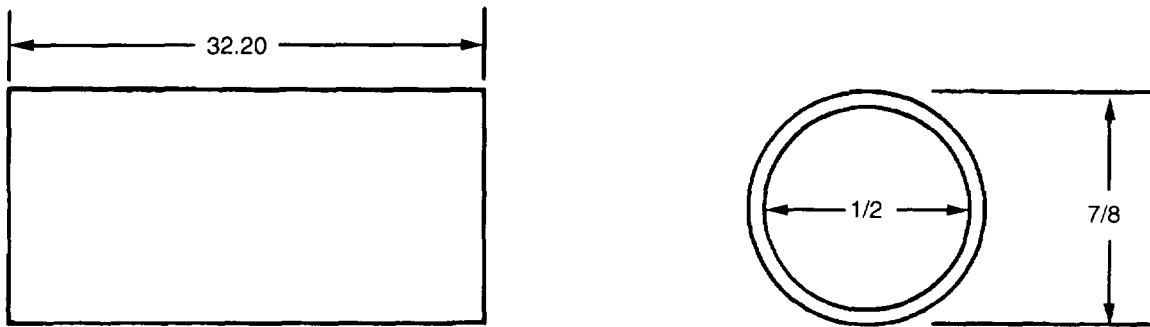
Figure G-7. Hydraulic Brake Tube Assembly, Right (M101A3 and M116A3)



1. Fabricate from tube, part number M3520-B80A00G, NSN 4710-00-200-0298.
2. Cut to proper length and bend as shown to create part number 12362795-1.
3. Install nut, part number 110357, on each end of tube assembly, as shown.

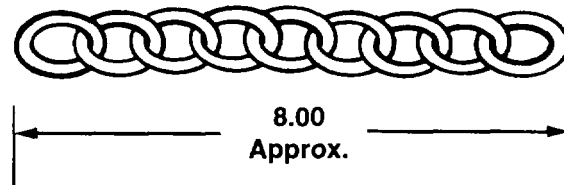


Figure G-8. Drawbar Clamp Spacer (M101A2 and M116A2)



1. Fabricate from tube, part number WWP441 Class A, NSN 4710-00-162-1018.
2. Cut to length as shown. Remove burrs.

Figure G-9. Adjustable Front Support Leg Chain



1. Fabricate from weldless chain, part number RRC271.
2. Cut to approximately 8 inches in length (12 links), as shown, to create part number RRC271-8.

**G-9/(G-10 blank)**

**APPENDIX H  
TORQUE VALUES FOR THREADED FASTENERS**

Paragraph Number	Paragraph Title	Page Number
H-1	General .....	H-1
H-2	Torque Limits.....	H-1
H-3	How To Use Torque Table .....	H-1
H-4	Tightening Metal Fasteners .....	H-3
H-5	Fastener Size and Thread Pattern .....	H-4
H-6	Fastener Grade.....	H-5

**H-1. GENERAL.**

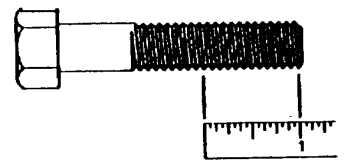
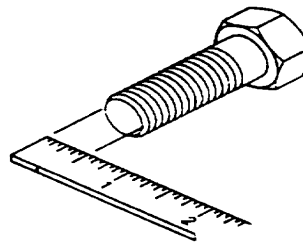
This section provides general torque limits for screws used on the M101 and MI 16 Series trailer. Special torque limits are indicated in the maintenance procedures for applicable components. The general torque limits given in this appendix shall be used when specific torque limits are not indicated in the maintenance procedure. These general torque limits cannot be applied to screws that retain rubber components. The rubber components will be damaged before the correct torque limit is reached. If a special torque limit is not given in the maintenance instructions, tighten the screw or nut until it touches the metal bracket, then tighten it one more turn.

**H-2. TORQUE LIMITS.**

Table H-1 lists dry torque limits. Dry torque limits are used on screws that do not have lubricants applied to threads. Table H-2 lists wet torque limits. Wet torque limits are used on screws that have high-pressure lubricants applied to threads.

**H-3. HOW TO USE TORQUE TABLE.**

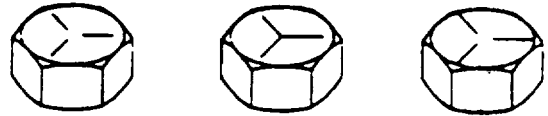
1. Measure the diameter of the screw to be installed.
2. Count the number of threads per inch or use a pitch gage.
3. Under the heading SIZE, look down the left-hand column until the diameter of screw to be installed is found (there will usually be two lines beginning with the same size).
4. In the second column under SIZE, find the number of threads per inch that matches the number of threads counted in step 2.



**H-3. HOW TO USE TORQUE TABLE (continued).**

5. To find the grade of the screw that is to be installed, match the markings on the head to the correct picture of CAPSCREW HEAD MARKINGS on the table.

Manufacturer's marks may vary.  
These are all SAE Grade No. 5 (3 lines).



6. Look down the column under the picture found in step 5 until the torque limit in foot-pounds for the diameter and threads per inch of the screw being installed is found.

Table H-1. Torque Limits for Dry Fasteners

**SAE CAPSCREW HEAD MARKINGS**

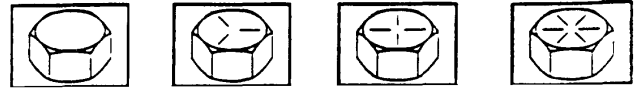


SIZE			TORQUE							
			SAE GRADE No. 1 or 2		SAE GRADE No. 5		SAE GRADE No. 6 or 7		SAE GRADE No. 8	
DIA. (IN.)	THREADS PER INCH	MM	FOOT- POUNDS	N•m	FOOT- POUNDS	N•m	FOOT- POUNDS	N•m	FOOT- POUNDS	N•m
1/4	20	6.35	5	6.78	8.0	10.85	10	13.56	12.0	16.27
1/4	28	6.35	6	8.14	10.0	13.56	—	—	14.0	18.98
5/16	18	7.94	11	14.92	17.0	23.05	19	25.76	24.0	32.52
5/16	24	7.94	13	17.63	19.0	25.76	—	—	27.0	36.61
3/8	16	9.53	18	24.41	31.0	42.04	34	46.10	44.0	59.66
3/8	24	9.53	20	27.12	35.0	47.46	—	—	49.0	66.44
7/16	14	11.11	28	37.97	49.0	66.44	55	74.58	70.0	94.92
7/16	20	—	30	40.68	55.0	74.58	—	—	78.0	105.77
1/2	13	12.70	39	52.88	75.0	101.70	85	115.26	105.0	142.38
1/2	20	—	41	55.60	85.0	115.26	—	—	120.0	162.78
9/16	12	14.28	51	69.16	110.0	149.16	120	162.72	155.0	210.18
9/16	18	—	55	74.58	120.0	162.72	—	—	170.0	230.52
5/8	11	15.88	63	85.43	150.0	203.40	167	226.45	210.0	284.76
5/8	18	—	95	128.82	170.0	230.52	—	—	240.0	325.44
3/4	10	19.05	105	142.38	270.0	356.12	280	379.68	375.0	506.50
3/4	16	—	115	155.94	295.0	400.02	—	—	420.0	596.52
7/8	9	22.23	160	216.96	375.0	536.62	440	596.64	605.0	820.38
7/8	14	—	175	237.30	435.0	599.85	—	—	675.0	915.30
1	8	25.40	235	318.66	590.0	800.04	660	694.96	910.0	1233.96
1	14	—	250	338.00	660.0	894.96	—	—	990.0	1342.44
1 1/8	—	25.58	—	—	800.0	1064.8	—	—	1280.0	1735.7
					880.0	1193.3	—	—	1444.0	1952.8
1 1/4	—	31.75	—	—	—	—	—	—	1820.0	2467.9
									2000.0	2712.0
1 3/8	—	34.93	—	—	1460.0	1979.8	—	—	2300.0	3227.3
					1680.0	2278.1	—	—	2720.0	3688.3
1 1/2	—	38.10	—	—	1940.0	2630.6	—	—	3160.0	4285.0
					2200.0	2963.2	—	—	3560.0	4827.4

**H-3. HOW TO USE TORQUE TABLE (continued).**

Table H-2. Torque Limits for Wet Fasteners

**SAE CAPSCREW HEAD MARKINGS**



SIZE			TORQUE							
			SAE GRADE No. 1 or 2		SAE GRADE No. 5		SAE GRADE No. 6 or 7		SAE GRADE No. 8	
DIA. (IN.)	THREADS PER INCH	MM	FOOT- POUNDS	N•m	FOOT- POUNDS	N•m	FOOT- POUNDS	N•m	FOOT- POUNDS	N•m
1/4	20	6.35	4.9	6.10	7.2	9.76	9.0	12.0	10.8	14.64
1/4	28	6.35	5.4	7.33	9.0	12.20	—	—	12.6	17.08
5/16	18	7.94	9.9	13.34	15.3	22.54	17.1	23.18	21.6	29.27
5/16	24	7.94	11.7	15.87	17.1	23.18	—	—	23.3	32.95
3/8	16	9.53	16.2	21.97	27.9	37.84	30.6	41.49	30.6	53.69
3/8	24	9.53	18.0	24.41	31.5	42.71	—	—	44.1	59.80
7/16	14	11.11	25.2	34.17	44.1	59.80	49.5	67.12	63.0	85.42
7/16	20	—	27.0	36.61	49.5	67.12	—	—	70.2	95.19
1/2	13	12.70	35.1	47.58	67.5	91.53	76.5	103.73	94.5	128.14
1/2	20	—	36.9	50.04	76.5	103.73	—	—	106.0	146.50
9/16	12	14.29	45.9	62.24	99.0	134.24	108.0	146.45	139.5	189.16
9/16	18	—	45.5	67.12	106.0	146.45	—	—	153.0	207.47
5/8	11	15.88	56.7	76.89	135.0	183.06	150.3	203.80	189.0	256.28
5/8	18	—	85.5	115.94	153.0	207.47	—	—	216.0	296.90
3/4	10	19.05	94.5	128.14	243.0	329.51	252.0	341.71	337.5	457.65
3/4	16	—	103.5	140.35	265.5	360.2	—	—	378.0	536.87
7/8	9	22.23	144.0	195.26	355.5	482.06	396.0	536.98	544.5	738.34
7/8	14	—	157.5	213.57	391.5	530.87	—	—	607.5	823.77
1	8	25.40	211.5	286.79	531.0	720.04	594.0	805.46	819.0	1110.56
1	14	—	225.0	305.10	594.0	805.46	—	—	891.0	1208.20
1-1/8	—	25.58	—	—	720.0	976.32	—	—	1152.0	1562.13
					792.0	1073.97	—	—	1296.0	1757.52
1-1/4	—	31.75	—	—	—	—	—	—	1638.0	2221.11
									1800.0	2440.80
1-3/8	—	34.93	—	—	1314.0	1781.82	—	—	2142.0	2904.57
					1512.0	2050.29	—	—	2448.0	3319.47
1-1/2	—	38.10	—	—	1746.0	2367.54	—	—	2844.0	3856.50
					1980.0	2684.88	—	—	3204.0	4344.66

**H-4. TIGHTENING METAL FASTENERS.**

When torquing a fastener, select a torque wrench whose range (Table H-3) fits the required torque value. A torque wrench is most accurate from 25 percent to 75 percent of its stated range. A torque wrench with a stated range of 0 to 100 will be most accurate from 25 to 75 foot-pounds. The accuracy of readings will decrease as you approach 0 foot-pounds or 100 foot-pounds. The ranges in Table H-3 are based on this principle.

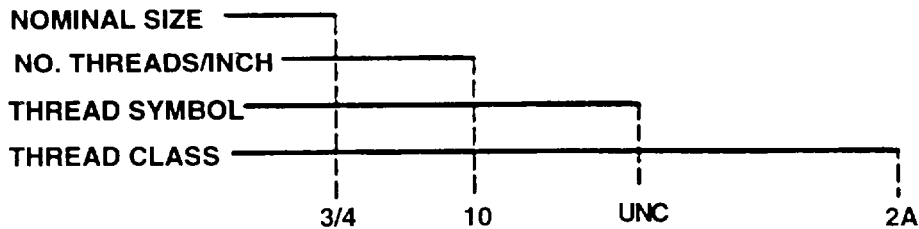
**H-4. TIGHTENING METAL FASTENERS (continued).**

<i>Table H-3. Torque Ranges</i>	
STATED RANGE	MOST EFFECTIVE RANGE
0-600 ft-lb	150-450 ft-lb
0-170 ft-lb	44-131 ft-lb
15-75 ft-lb	30-60 ft-lb

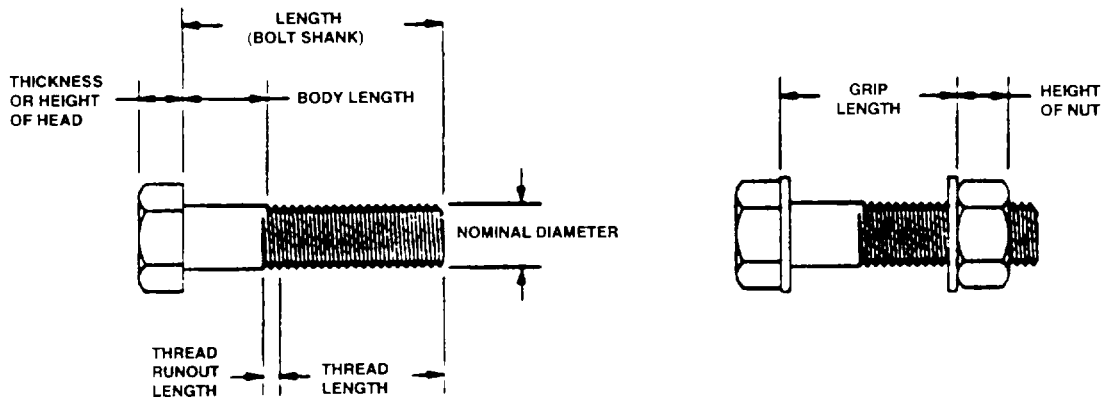
**H-5. FASTENER SIZE AND THREAD PATTERN.**

Threaded fasteners are categorized according to diameter of the fastener shank. Thread styles are divided into broad groups, the two most common being coarse (Unified Coarse-UNC) and fine (Unified Fine-UNF). These groups are defined by the number of threads per inch on the bolt shanks. In addition, threads are categorized by thread class (Table H-4), which is a measure of the degree between threads of bolt or screw (external threads) and threads of the attaching nut or tapped hole (internal threads of the attaching nut or tapped hole) (internal threads). The most common thread class for bolts and screws is Class 2.

<i>Table H-4. Thread Classes and Description</i>		
EXTERNAL	INTERNAL	INTERNAL
1A	1B	LOOSE FIT
2A	2B	MEDIUM FIT
3A	3B	CLOSE FIT



**NOTE:** Unless followed with -LH (e.g., 3/4-10 UNC-2A-LH), threads are right-hand.



**H-6. FASTENER GRADE.**

In addition to being classified by thread type, thread fasteners are also classified by material. The most familiar fastener classification system is the SAE grading system (Table H-5).

*Table H-5. SAE Screw and Bolt Markings*

<b>SCREWS</b>	<b>BOLTS</b>
SAE GRADE 2 NO MARKING	SAE GRADE 6 4 RADIAL DASHES 90° APART
SAE GRADE 3 2 RADIAL DASHES 180° APART	SAE GRADE 7 5 RADIAL DASHES 72° APART
SAE GRADE 5 3 RADIAL DASHES 120° APART	SAE GRADE 8 6 RADIAL DASHES 60° APART

**Markings on Hex Locknuts**

GRADE A - No Marks  
 GRADE B - 3 Marks  
 GRADE C - 6 Marks

GRADE A - No Marks  
 GRADE B - Letter B  
 GRADE C - Letter C

GRADE A - No Notches  
 GRADE B - 1 Notch  
 GRADE C - 2 Notches

**H-5/(H-6 blank)**

**APPENDIX I  
LUBRICATION INSTRUCTIONS**

Paragraph Number	Paragraph Title	Page Number
I-1	General .....	I-1
I-2	Specific Lubrication Instructions.....	I-1
I-3	Lubrication Chart .....	I-2

**I-1. GENERAL.**

**NOTE**

These Instructions are MANDATORY.

- a. The M101 and MI16 Series trailers must receive lubrication with approved lubricants at recommended intervals in order to be mission-ready at all times.
- b. The KEY (p. 1-4) lists lubricants to be used in all temperature ranges and shows the intervals.
- c. The Lubncation Chart (p. 1-3) shows lubrication points, items to be lubricated, required lubricants, and recommended intervals for lubrication. Any special lubricating instructions for specific components are contained in NOTES (p. 1-4).
- d. Recommended intervals are based on normal conditions of operation; under extreme conditions, lubricants should always be changed more frequently. When in doubt, notify your supervisor.

**I-2. SPECIFIC LUBRICATION INSTRUCTIONS.**

- a. Keep all lubricants in a closed container and store in a clean, dry place away from extreme heat. Keep container covers clean and do not allow dust, dirt, or other foreign material to mix with lubricants. Keep all lubrication equipment clean and ready for use.
- b. Maintain a record of lubrication performed and report any problems noted during lubrication. Refer to DA Pam 738-750 for maintenance forms and procedures for recording and reporting any findings.

**WARNING**

**Wipe excess lubricant from the area of brakeshoe linings to prevent grease from soaking the linings. If brakeshoe linings become soaked, have Unit maintenance replace them. Failure to follow this warning may cause brakes to malfunction, resulting in serious injury or death to personnel.**

- c. Keep all external parts not requiring lubrication free of lubricants. After lubrication, wipe off excess oil or grease to prevent accumulation of foreign matter.
- d. After parts are cleaned, rinse and dry them thoroughly. Apply a light grade of oil to all polished metal surfaces to prevent rusting.

---

**I-2. SPECIFIC LUBRICATION INSTRUCTIONS (continued).**

---

- e. When authorized to install new parts, remove any preservative materials, such as rust preventive compound or protective grease, prior to installation. Apply lubricant prescribed in lubrication Instructions if required.
- f. Clean and lubricate bearings as specified in TM 9-214.
- g. Refer to FM 9-207 for lubrication instructions in cold weather.
- h. After operation in mud or in sandy or dusty conditions, clean and inspect all points of lubrication for fouled lubricants. Change lubricants as required.
- i. After any fording operation, lubricate vehicle in accordance with lubrication instructions.

**WARNING**

**Drycleaning solvent P-D-680 is toxic and flammable. Always wear protective goggles and gloves, and use only in a well-ventilated area. Avoid contact with skin, eyes, and clothes, and DO NOT breathe vapors. DO NOT use near open flame or excessive heat.**

- j. Clean all fittings and the area around lubrication points with drycleaning solvent (Item 14, Appendix F) or the equivalent before lubricating equipment. After lubrication, wipe off excess oil or grease to prevent accumulation of foreign matter.

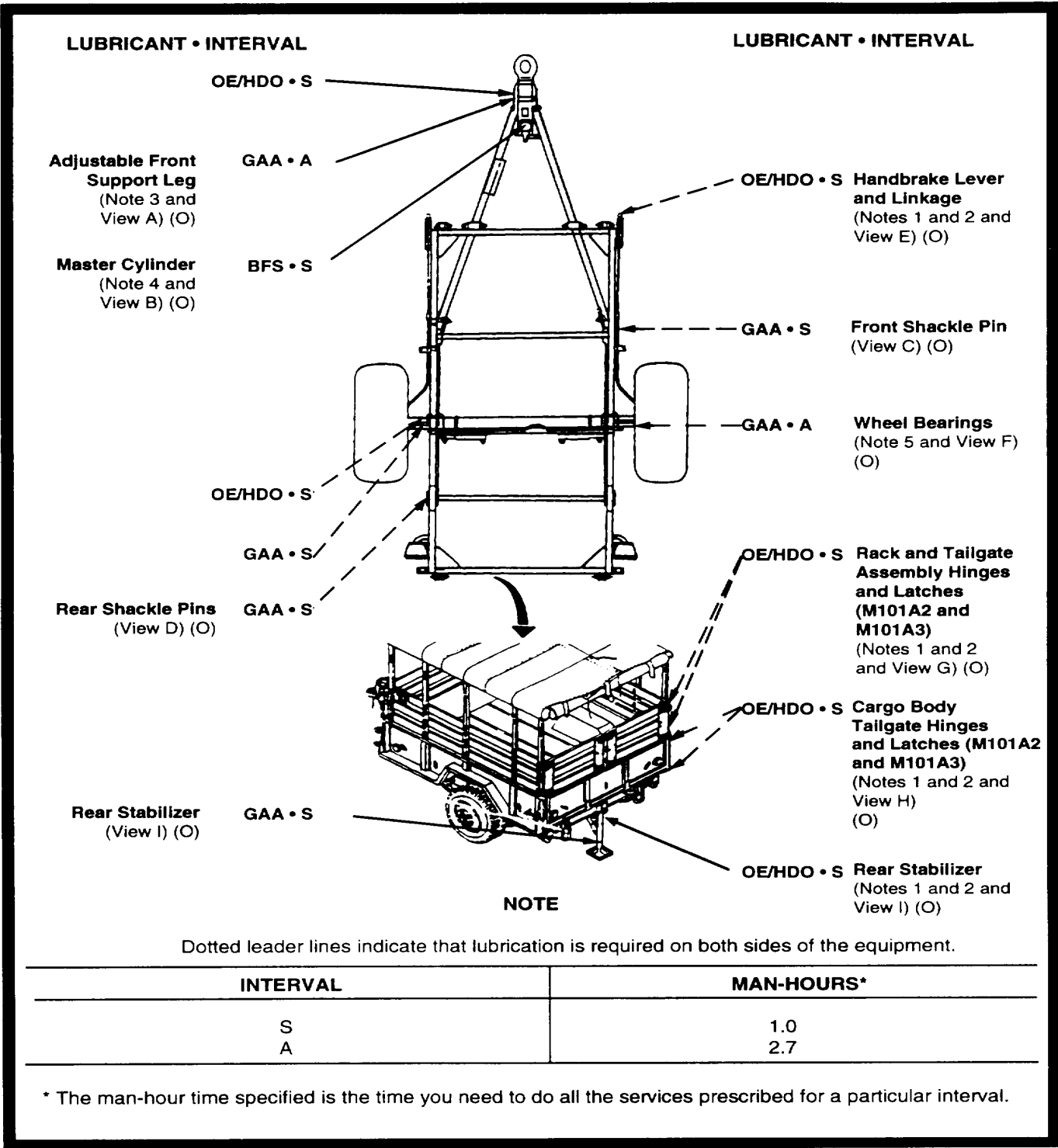
---

**I-3. LUBRICATION CHART.**

---

- a. The Lubrication Chart covers lubrication points for the MI01 A2 and MI01 A3 two-wheel, 3/4-ton cargo trailers; the M116A2 and MI 16A2E1 two-wheel, 3/4-ton chassis trailers; and the MI 16A3 two-wheel, 1-ton chassis trailer. The lubrication points shown are for all models unless otherwise noted.
- b. Intervals (on-condition or hard time) and related man-hour times are based on normal operation. The man hour time specified is the time you need to do all the services prescribed for a particular interval. Decrease the intervals if your lubricants are contaminated or if you are operating equipment under adverse conditions, including longer than usual operating hours. The intervals may be extended during periods of low activity. If extended, adequate preservation precautions must be taken.
- c. The lowest level of maintenance authorized to lubricate a point is indicated in parentheses by use of the following: (C) Operator/Crew or (O) Unit maintenance.





- KEY -				
LUBRICANTS	EXPECTED TEMPERATURE			INTERVALS
	Above +32°F (Above 0°C)	+40°F to -10°F (+4°C to -23°C)	0°F to -65°F (-18°C to -54°C)	
OE/HDO (MIL-L-2104)  Lubricating Oil, Internal Combustion Engine, Tactical Service	OE/HDO-30	OE/HDO-10	—	FOR ARCTIC OPERATIONS, REFER TO FM 9-207  S – Semiannual  A – Annual
OEA (MIL-L-46167)  Lubricating Oil, Internal Combustion Engine, Arctic	—	—	OEA	
BFS (MIL-B-46176)  Brake Fluid Silicone, Automotive	All Temperatures			
GAA (MIL-G-10924E&F)  Grease, Automotive and Artillery	All Temperatures			

NOTES:

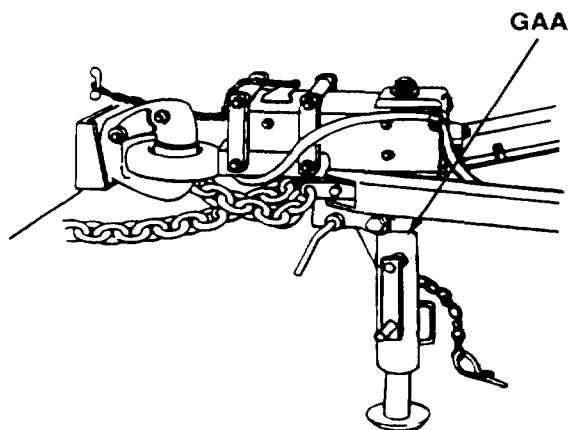
**WARNING**

**Drycleaning solvent P-D-680 is toxic and flammable. Always wear protective goggles and gloves, and use only in a well-ventilated area. Avoid contact with skin, eyes, and clothes, and DO NOT breathe vapors. DO NOT use near open flame or excessive heat.**

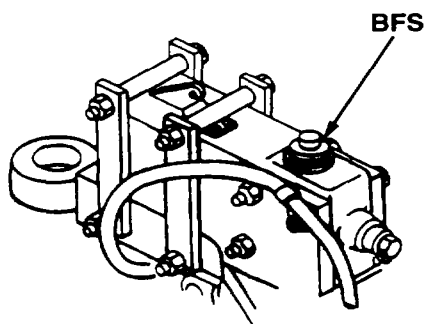
- For prolonged operation of equipment in extreme cold (temperatures below -10°F [23 C]), remove lubricants prescribed in the KEY for temperatures above -10°F (-230C). Clean parts with drycleaning solvent (Item 14, Appendix F). Lubricate with lubricants specified in the KEY for temperatures of 0°F to -65°F (18°C to -54°C). If OEA lubricant is required to meet the temperature changes prescribed in the KEY, OEA lubricant is to be used in place of OE/HDO-10 lubricant for all temperature ranges where OE/HDO-10 lubricant is specified in the key.

- Oil Can Points: Semiannually or as required, lubricate the following with OE/HDO: handbrake levers and linkage, adjustable front support leg pivot points and handcrank, rear stabilizer pivot points and latches, cargo body tailgate hinges and latches, and rack and tailgate assembly hinges and latches.
- Adjustable Front Support Leg: Annually remove, clean, inspect, pack with GAA, and install (para 4-51).
- Master Cylinder: Semiannually fill to within 1/4 inch (6.35 mm) of top with BFS.
- Wheel Bearings: Annually remove, clean, inspect, pack with GAA, and Install (para 4-43). Refer to TM 9-214.
- Springs: Do not lubricate.

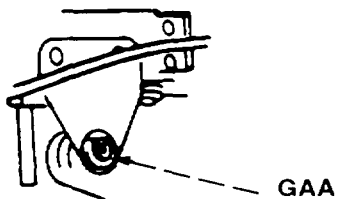
(A) ADJUSTABLE FRONT SUPPORT LEG



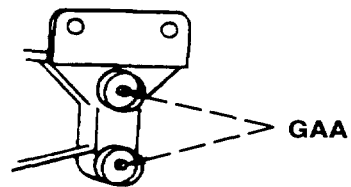
(B) MASTER CYLINDER



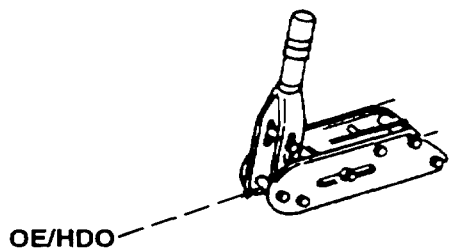
(C) FRONT SHACKLE PIN



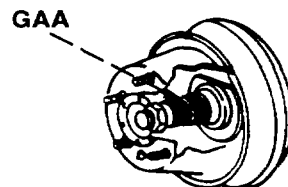
(D) REAR SHACKLE PINS



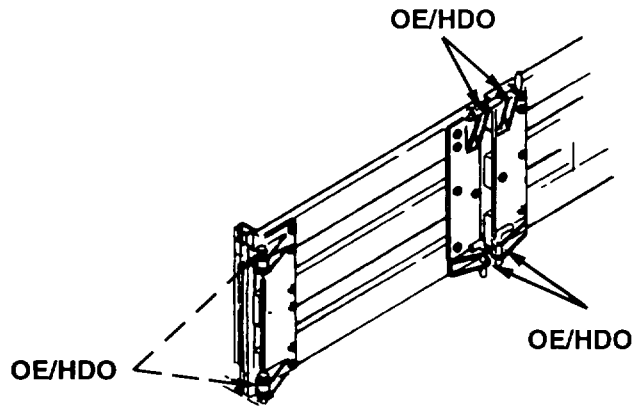
(E) HANDBRAKE LEVER AND LINKAGE



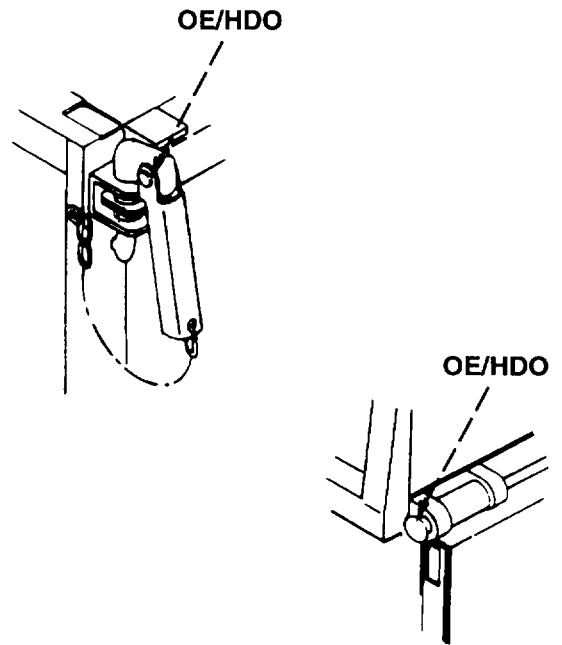
(F) WHEEL BEARINGS



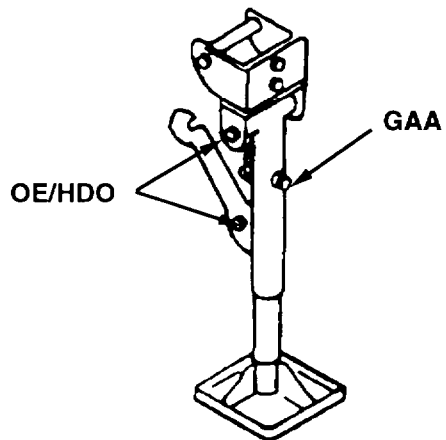
**G RACK AND TAILGATE ASSEMBLY HINGES AND LATCHES (M101A2 and M101A3)**



**H CARGO BODY TAILGATE HINGES AND LATCHES (M101A2 and M101A3)**



**I REAR STABILIZER**



INDEX

Subject	Page
<b>A</b>	
Abbreviations .....	1-2
Acronyms .....	1-2
Actuator Assembly, Hydraulic Brake .....	4-63
Additional Authorization List .....	D-1
Adjustable Front Support Leg.....	4-101
Administrative Storage	
Care of Equipment in.....	4-124
Definition of .....	4-122
Preparation of Equipment for .....	4-123
Procedures for Common Components .....	4-125
Removal of Equipment from.....	4-126
Army Materiel, Destruction of, To Prevent Enemy Use.....	1-1
Axle .....	5-1
<b>B</b>	
Basic Issue Items .....	C-1
Bearings	
Cleaning .....	4-36
Wheel .....	4-83
Bleeding Hydraulic Brake System .....	4-81
Body, Cargo .....	4-110
Brakedrum	
Maintenance .....	4-83
Repair .....	5-3
Brake, Hydraulic Actuator Assembly	
Adjustment .....	4-60
Bleeding .....	4-81
Lines .....	4-76
Maintenance .....	4-55
Principles of Operation .....	1-17
Replacement .....	4-63
Brake Line, Hydraulic	
General Maintenance .....	4-38
Replacement .....	4-76
Bulletins .....	A-2
<b>C</b>	
Cable	
Electrical, Cleaning.....	4-36
Intervehicular .....	4-46

Subject	Page
<b>C (continued)</b>	
Canvas Cover Assembly (M101A2 and M101A3)	
Grommet and Rope.....	4-116
Installation .....	2-11
Removal .....	2-23
Repair .....	5-7
Care of Equipment in Administrative Storage .....	4-124
Cargo Body (M101A2 and M101A3) .....	4-110
Castings, Cleaning .....	4-36
Cautions .....	vvi
Chains, Safety .....	4-103
Chassis Wiring Harness .....	4-43
Cleaning Instructions	
Bearings .....	4-36
Castings .....	4-36
Electrical Cables.....	4-36
Flexible Hoses.....	4-36
Forgings .....	4-36
General .....	4-35
Machined Parts 4-36 .....	4-36
Oil Seals . .....	4-36
Steam Cleaning .....	4-35
Cold, Operation in Extreme .....	2-26
Common Tools and Equipment.....	4-1
Components	
Common, Procedures for Storage of .....	4-125
Major, Location and Description .....	1-5
Of End Item .....	C-1
Composite Stoplight-Taillight .....	4-39
Controls and Indicators .....	2-1
Corrosion Prevention and Control .....	1-3
Coupling Trailer to Towing Vehicle .....	2-16
Cover Assembly, Canvas (M101A2 and M101A3)	
Grommet and Rope.....	4-116
Installation .....	2-11
Removal .....	2-23
Repair .....	5-7
Cylinder, Master .....	4-73
Cylinder, Wheel .....	4-61

**D**

Data, Equipment .....	1-14
Data Plates	
Contents .....	1-10
Location .....	1-10
Replacement .....	4-118

Subject	Page
<b>D (continued)</b>	
Destruction of Army Materiel To Prevent Enemy Use.....	1-1
Diagram, Wiring .....	4-48
Differences Between Models.....	1-12
Direct Support and General Support Maintenance	
Axle Maintenance .....	5-1
Brakedrum and Tire Maintenance .....	5-3
Drawbar Replacement.....	4-99
Dusty Areas, Operation in .....	2-27

**E**

Electrical Cables, Cleaning.....	4-36
Electrical Ground Points.....	4-38
Electrical System Maintenance .....	4-39
Electrical Troubleshooting	
Operator/Crew.....	3-2
Unit .....	4-7
Equipment	
Administrative Storage, Preparation for .....	4-122
Care of, in Administrative Storage.....	4-124
Characteristics, Capabilities, and Features.....	1-4
Common Tools and .....	4-1
Data .....	1-14
Removal of, from Administrative Storage.....	4-126
Shipment, Preparation for .....	4-126
Support .....	4-1
Test, Measurement, and Diagnostic .....	4-1
Equipment Improvement Recommendations, Reporting .....	1-2
Expendable and Durable Items List .....	F-1
Eyebolt .....	4-98

**F**

Fastener Grade .....	H-5
Fastener Size and Thread Pattern .....	H-4
Field Manuals .....	A-1
Flexible Hoses, Cleaning.....	4-36
Fluid Disposal .....	4-38
Fording .....	2-28
Forgings, Cleaning .....	4-36
Forms .....	A-1
Forms, Maintenance .....	1-1
Frame .....	5-6
Front Support Leg, Adjustable.....	4-101

Subject	Page
<b>G</b>	
General Maintenance	
Bearings .....	4-36
Castings .....	4-36
Electrical Cables.....	4-36
Electrical Ground Points.....	4-38
Flexible Hoses .....	4-36
Fluid Disposal .....	4-38
Forgings .....	4-36
General .....	4-35
Hydraulic Brake Lines.....	4-38
Inspection Instructions.....	4-36
Machined Parts .....	4-36
Oil Seals .....	4-36
Painting .....	4-38
Ports .....	4-38
Preservation of Parts.....	4-37
Steam Cleaning.....	4-35
Tagging Parts .....	4-37
Work Safety .....	4-34
Grommet, Canvas Cover Assembly .....	4-116
Ground Points, Electrical.....	4-38

**H**

Halt/Parking, at .....	2-28
Handbrake	
Adjustment .....	4-54
Cable Replacement.....	4-46
Lever .....	4-49
Linkage .....	4-49
Operating .....	2-11
Handling, Safety, and Care .....	1-3
Hanger, Spring .....	4-92
Harness, Chassis Wiring .....	4-43
Heat, Operation in Extreme .....	2-26
Hoses, Flexible .....	4-36
How To Use This Manual .....	vi
Hub -83 .....	4-83
Humidity, Operation in High.....	2-27
Hydraulic Brake Actuator Assembly	
Bleeding .....	4-81
General Maintenance .....	4-38
Ports .....	4-38
Replacement .....	4-63
Hydraulic Brake System .....	1-17



<b>Subject</b>	<b>Page</b>
Illustrated List of Manufactured Items .....	G-1
Indexing .....	vi
Indicators and Controls .....	2-1
Inspection Instructions	
General Maintenance .....	4-36
Service upon Receipt .....	4-2
Intervehicular Cable .....	4-46
<b>L</b>	
Leakage Definitions .....	2-5
Leg, Front Support, Adjustable.....	4-101
Lever, Handbrake .....	4-49
Lift Shackle .....	4-97
Loading .....	2-15
Lubrication	
Chart .....	1-2
Instructions .....	3-1, 1-1
<b>M</b>	
M101A2 and M101A3	
Canvas Cover Assembly Grommet and Rope .....	4-116
Canvas Cover Assembly Repair .....	5-7
Cargo Body 4-110	
Rack and Tailgate Assembly	
Installation.....	2-12
Removal 2-23	
Machined Parts, Cleaning .....	4-36
Maintenance	
Forms .....	1-1
Functions .....	B-1
Procedures, Direct Support and General Support.....	5-1
Procedures, Operator/Crew.....	3-2
Records .....	1-1
Reports .....	1-1
Unit .....	4-1
Maintenance Allocation Chart.....	B-1
Maintenance, General	
Bearings .....	4-36
Castings .....	4-36
Electrical Cables .....	4-36
Electrical Ground Points .....	4-38
Flexible Hoses .....	4-36
Fluid Disposal .....	4-38
Forgings .....	4-36

Subject	Page
<b>M (continued)</b>	
Hydraulic Brake Lines .....	4-38
Inspection Instructions .....	4-36
Machined Parts .....	4-36
Oil Seals .....	4-36
Painting .....	4-38
Ports .....	4-38
Preservation of Parts .....	4-37
Steam Cleaning .....	4-35
Tagging Parts.....	4-37
Work Safety .....	4-34
Major Components, Location and Description .....	1-5
Manuals, Field .....	A-1
Manuals, Technical .....	A-2
Manual, This	
How To Use .....	vi
Scope .....	1-1
Manufactured Items Part Number Index .....	G-1
Manufacturing Instructions .....	G-3
Master Cylinder .....	4-73
Material, Destruction of To Prevent Enemy Use .....	1-1
Metal Fasteners, Tightening.....	H-3
Models, Differences Between.....	1-12
Mud. Operation .....	2-27
<b>N</b>	
Notes .....	vii
<b>O</b>	
Oil Seals, Cleaning .....	4-36
Operation	
In Dusty Areas .....	2-27
In Extreme Cold .....	2-26
In Extreme Heat.....	2-26
In High Humidity.....	2-27
In Mud .....	2-27
In Saltwater Areas.....	2-27
In Sandy Areas .....	2-27
In Snow .....	2-27
Under Unusual Conditions.....	2-26
Under Usual Conditions.....	2-11
Operator/Crew	
Electrical Troubleshooting.....	3-2
Maintenance Instructions.....	3-1

Subject	Page
<b>O (continued)</b>	
Preventive Maintenance Checks and Services (PMCS).....	2-3
Quick Guide to Troubleshooting .....	3-3
Troubleshooting Chart .....	3-4
Operator's Controls and Indicators.....	2-1

**P**

Painting	
General Maintenance.....	4-38
Identification Marking.....	4-38
Instructions.....	4-121
Pamphlets .....	A-2
Parking/At Halt .....	2-28
Parts	
Preservation.....	4-37
Repair .....	4-1
Tagging .....	4-37
Plates, Data	
Contents .....	1-10
Location .....	1-10
Replacement.....	4-118
PMCS, Operator/Crew	
General Procedures.....	2-4
Leakage Definitions .....	2-5
Operator/Crew .....	2-6
Reporting Repairs .....	2-3
Service Intervals .....	2-3
Specific Procedures.....	2-4
Table .....	4-5
PMCS, Unit	
General Procedures.....	4-3
Reporting Repairs.....	4-3
Service Intervals .....	4-3
Specific Procedures.....	4-4
Table .....	4-5
Ports .....	4-38
Preservation of Parts .....	4-37
Principles of Operation, Hydraulic Brake System.....	1-17
Publications      A-3	

**Q**

Quality Assurance .....	11-2
Quick Guide to Troubleshooting	
Operator/Crew.....	3-3
Unit .....	4-9

Subject	Page
<b>R</b>	
Rack and Tailgate Assembly (M101A2 and M101A3)	
Installation .....	2-12
Removal .....	2-23
Rear Stabilizer .....	4-119
Records, Maintenance .....	1-1
References .....	1-1
Reflector (M101A2 and M101A3) .....	4-117
Removal of Equipment from Administrative Storage .....	4-126
Repair Parts .....	4-1, E-1
Repair Parts and Special Tools List	
Abbreviations in .....	E-8
Explanation of Columns in .....	E-2
How To Locate Repair Parts .....	E-7
Repair Parts List .....	E-1
Special Information .....	E-7
Repairs, Reporting .....	2-3, 4-3
Reports, Maintenance .....	1-1
Rocky Terrain, Operation in .....	2-27

**S**

Safety, Care, and Handling .....	1-3
Safety Chains .....	4-103
Safety. Work .....	4-34
Saltwater Areas, Operation n .....	2-27
Sandy Areas, Operation in .....	2-27
Service Brake	
Adjustment .....	4-60
Maintenance .....	4-55
Service Intervals	
Operator/Crew PMCS .....	2-3
Unit PMCS .....	4-3
Service upon Receipt	
Inspection Instructions .....	4-2
Servicing Instructions .....	4-2
Shackle, Lift .....	4-97
Shipment, Preparation of Equipment for .....	1-1, 4-126
Shock Absorbers .....	4-108
Snow, Operation n .....	2-27
Special Tools, TMDE, and Support Equipment .....	4-1
Spring Assembly .....	4-104
Spring Hanger .....	4-92
Stabilizer, Rear .....	4-119
Steam Cleaning .....	4-35
Stenciling .....	4-121
Stoptlight-Taillight, Composite .....	4-39

Subject	Page
<b>S (continued)</b>	
Storage, Administrative	
Care of Equipment in.....	4-124
Definition of .....	4-122
Preparation for.....	1-1
Preparation of Equipment for .....	4-123
Procedures for Common Components .....	4-125
Removal of Equipment from.....	4-126
Support Equipment .....	4-1
Support Leg, Front, Adjustable.....	4-101

**T**

Table of Contents .....	i
Tagging Parts .....	4-37
Tailgate (M101A2 and M101A3).....	4-113
Tailgate and Rack Assembly (M101A2 and M101A3)	
Installation .....	2-12
Removal .....	2-23
Technical Manuals .....	A-1A-
Test, Measurement, and Diagnostic Equipment .....	4-1
Tire	
Maintenance .....	4-91
Repair .....	5-5
Replacement .....	4-90
Tool and Test Equipment Requirements.....	B-3
Tools	
Common .....	4-1
Special .....	4-1
Torque Limits .....	H-1
Torque Values for Threaded Fasteners .....	H-1
Towing Instructions .....	2-19
Troubleshooting Chart	
Operator/Crew.....	3-4
Unit .....	4-10
Troubleshooting, Electrical	
Operator/Crew.....	3-2
Unit .....	4-7
Troubleshooting, Quick Guide to	
Operator/Crew.....	3-3
Unit .....	4-9
Tube Maintenance .....	4-91

**U**

U-Bolt Replacement (M101A2 and M101A3).....	4-115
Uncoupling Trailer from Towing Vehicle.....	2-21

Subject	Page
<b>U (continued)</b>	
Unit Maintenance	
PMCS .....	4-3
Troubleshooting Procedures .....	4-7
Unusual Conditions, Operation Under	
Fording .....	2-28
In Dusty Areas .....	2-27
In Extreme Cold .....	2-26
In Extreme Heat .....	2-26
In High Humidity .....	2-27
In Mud .....	2-27
In Saltwater Areas .....	2-27
In Sandy Areas .....	2-27
In Snow .....	2-27
Usual Conditions, Operation Under.....	2-11

**W**

Warnings .....	vi
Warning Summary .....	a
Warranty Information .....	1-3
Wheel	
Bearings .....	4-83
Cylinder .....	4-61
Replacement .....	4-90
Wiring Diagram .....	4-48
Wiring Harness, Chassis .....	4-43
Work Safety .....	4-34

By Order of the Secretary of the Army:

**DENNIS J. REIMER**  
*General, United States Army*  
*Chief of Staff*

Official:

  
**JOEL B. HUDSON**  
*Administrative Assistant to the*  
*Secretary of the Army*  
03465

DISTRIBUTION:

To be distributed in accordance with the initial distribution number (IDN) 390560, requirements for TM9-2330-202-14&P.





RECOMMENDED CHANGES TO EQUIPMENT TECHNICAL PUBLICATIONS



THEN...JOT DOWN THE DOPE ABOUT IT ON THIS FORM, CAREFULLY TEAR IT OUT, FOLD IT AND DROP IT IN THE MAIL.

**SOMETHING WRONG** WITH THIS PUBLICATION?

FROM: (PRINT YOUR UNIT'S COMPLETE ADDRESS)

DATE SENT

PUBLICATION NUMBER

TM X-XXXX-XXX-XX

PUBLICATION DATE

Date of TM

PUBLICATION TITLE

Title of TM

BE EXACT. PIN-POINT WHERE IT IS

PAGE NO	PARA-GRAPH	FIGURE NO	TABLE NO
---------	------------	-----------	----------

24-1

—

—

—

IN THIS SPACE TELL WHAT IS WRONG AND WHAT SHOULD BE DONE ABOUT IT:

*Item no. 18.  
The part number supplied appears to be wrong. When we order it, we receive a retaining ring instead of an axle tube.*

**SAMPLE**

PRINTED NAME, GRADE OR TITLE, AND TELEPHONE NUMBER

SIGN HERE:

**SAMPLE**

FILL IN YOUR  
UNIT'S ADDRESS  
↓

FOLD BACK

DEPARTMENT OF THE ARMY

COB 1st BN 2d BDE  
Fort Hood, Tx. 76544

POSTAGE AND FEES PAID  
DEPARTMENT OF THE ARMY  
DOD314



OFFICIAL BUSINESS  
PENALTY FOR PRIVATE USE \$300

Commander  
U.S. Army Tank-automotive  
and Armaments Command  
ATTN: AMSTA-AC-NML  
Rock Island, IL 61299-7630

TEAR ALONG PERFORATED LINE

RECOMMENDED CHANGES TO EQUIPMENT TECHNICAL PUBLICATIONS

**SOMETHING WRONG WITH THIS PUBLICATION?**



THEN...JOT DOWN THE DOPE ABOUT IT ON THIS FORM, CAREFULLY TEAR IT OUT, FOLD IT AND DROP IT IN THE MAIL.

FROM: (PRINT YOUR UNIT'S COMPLETE ADDRESS)

DATE SENT

PUBLICATION NUMBER

TM 9-2330-384-14&P

PUBLICATION DATE

9 July 1990

PUBLICATION TITLE Operator's, Unit, DS, and GS Maintenance Manual Including RPSTL for Semitrailer, M1062 (NSN 2330-01-275-7475)

BE EXACT. PIN-POINT WHERE IT IS

PAGE NO	PARA-GRAPH	FIGURE NO	TABLE NO
---------	------------	-----------	----------

IN THIS SPACE TELL WHAT IS WRONG AND WHAT SHOULD BE DONE ABOUT IT:

PRINTED NAME, GRADE OR TITLE, AND TELEPHONE NUMBER

SIGN HERE:

FILL IN YOUR  
UNIT'S ADDRESS



FOLD BACK

TEAR ALONG PERFORATED LINE

DEPARTMENT OF THE ARMY

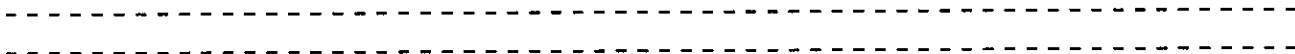


POSTAGE AND FEES PAID  
DEPARTMENT OF THE ARMY  
DOD314



OFFICIAL BUSINESS  
PENALTY FOR PRIVATE USE \$300

Commander  
U.S. Army Tank-automotive  
and Armaments Command  
ATTN: AMSTA-AC-NML  
Rock Island, IL 61299-7630



RECOMMENDED CHANGES TO EQUIPMENT TECHNICAL PUBLICATIONS

**SOMETHING WRONG WITH THIS PUBLICATION?**



*THEN...JOT DOWN THE DOPE ABOUT IT ON THIS FORM, CAREFULLY TEAR IT OUT, FOLD IT AND DROP IT IN THE MAIL.*

FROM: (PRINT YOUR UNIT'S COMPLETE ADDRESS)

DATE SENT

PUBLICATION NUMBER

TM 9-2330-384-14&P

PUBLICATION DATE

9 July 1990

PUBLICATION TITLE Operator's, Unit, DS, and GS Maintenance Manual Including RPSTL for Semitrailer, M1062 (NSN 2330-01-275-7475)

BE EXACT. PIN-POINT WHERE IT IS

PAGE NO	PARA-GRAPH	FIGURE NO	TABLE NO

IN THIS SPACE TELL WHAT IS WRONG AND WHAT SHOULD BE DONE ABOUT IT:

PRINTED NAME, GRADE OR TITLE, AND TELEPHONE NUMBER

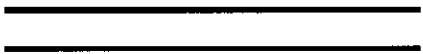
SIGN HERE:

FILL IN YOUR  
UNIT'S ADDRESS



FOLD BACK

DEPARTMENT OF THE ARMY



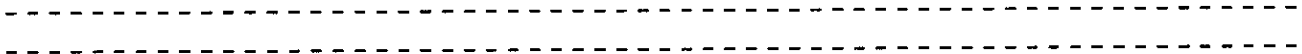
OFFICIAL BUSINESS  
PENALTY FOR PRIVATE USE \$300

POSTAGE AND FEES PAID  
DEPARTMENT OF THE ARMY  
DOD314



Commander  
U.S. Army Tank-automotive  
and Armaments Command  
ATTN: AMSTA-AC-NML  
Rock Island, IL 61299-7630

TEAR ALONG PERFORATED LINE





FILL IN YOUR  
UNIT'S ADDRESS



FOLD BACK

DEPARTMENT OF THE ARMY



OFFICIAL BUSINESS  
PENALTY FOR PRIVATE USE \$300

POSTAGE AND FEES PAID  
DEPARTMENT OF THE ARMY  
DOD314



TEAR ALONG PERFORATED LINE

Commander  
U.S. Army Tank-automotive  
and Armaments Command  
ATTN: AMSTA-AC-NML  
Rock Island, IL 61299-7630



## THE METRIC SYSTEM AND EQUIVALENTS

### LINEAR MEASURE

- 1 Centimeter = 10 Millimeters = 0.01 Meters = 0.3937 Inches
- 1 Meter = 100 Centimeters = 1,000 Millimeters = 39.37 Inches
- 1 Kilometer = 1,000 Meters = 0.621 Miles

### SQUARE MEASURE

- 1 Sq Centimeter = 100 Sq Millimeters = 0.155 Sq Inches
- 1 Sq Meter = 10,000 Sq Centimeters = 10.76 Sq Feet
- 1 Sq Kilometer = 1,000,000 Sq Meters = 0.386 Sq Miles

### CUBIC MEASURE

- 1 Cu Centimeter = 1,000 Cu Millimeters = 0.06 Cu Inches
- 1 Cu Meter = 1,000,000 Cu Centimeters = 35.31 Cu Feet

### LIQUID MEASURE

- 1 Milliliter = 0.001 Liters = 0.0338 Fluid Ounces
- 1 Liter = 1,000 Milliliters = 33.82 Fluid Ounces

### TEMPERATURE

- $5/9 (°F - 32) = °C$
- 212° Fahrenheit is equivalent to 100° Celsius
- 90° Fahrenheit is equivalent to 32.2° Celsius
- 32° Fahrenheit is equivalent to 0° Celsius
- $9/5 C° + 32 = F°$

### WEIGHTS

- 1 Gram = 0.001 Kilograms = 1,000 Milligrams = 0.035 Ounces
- 1 Kilogram = 1,000 Grams = 2.2 lb.
- 1 Metric Ton = 1,000 Kilograms = 1 Megagram = 1.1 Short Tons

### APPROXIMATE CONVERSION FACTORS

TO CHANGE	TO	MULTIPLY BY
Inches	Centimeters	2.540
Feet	Meters	0.305
Yards	Meters	0.914
Miles	Kilometers	1.609
Square Inches	Square Centimeters	6.451
Square Feet	Square Meters	0.093
Square Yards	Square Meters	0.836
Square Miles	Square Kilometers	2.590
Acres	Square Hectometers	0.405
Cubic Feet	Cubic Meters	0.028
Cubic Yards	Cubic Meters	0.765
Fluid Ounces	Milliliters	29.573
Pints	Liters	0.473
Quarts	Liters	0.946
Gallons	Liters	3.785
Ounces	Grams	28.349
Pounds	Kilograms	0.454
Short Tons	Metric Tons	0.907
Pound-Feet	Newton-Meters	1.356
Pounds Per Square Inch	Kilopascals	6.895
Miles Per Gallon	Kilometers Per Liter	0.425
Miles Per Hour	Kilometers Per Hour	1.609
TO CHANGE	TO	MULTIPLY BY
Centimeters	Inches	0.394
Meters	Feet	3.280
Meters	Yards	1.094
Kilometers	Miles	0.621
Square Centimeters	Square Inches	0.155
Square Meters	Square Feet	10.764
Square Meters	Square Yards	1.196
Square Kilometers	Square Miles	0.386
Square Hectometers	Acres	2.471
Cubic Meters	Cubic Feet	35.315
Cubic Meters	Cubic Yards	1.308
Milliliters	Fluid Ounces	0.034
Liters	Pints	2.113
Liters	Quarts	1.057
Liters	Gallons	0.264
Grams	Ounces	0.035
Kilograms	Pounds	2.205
Metric Tons	Short Tons	1.102
Newton-Meters	Pound-Feet	0.738
Kilopascals	Pounds Per Square Inch	0.145
Kilometers Per Liter	Miles Per Gallon	2.354
Kilometers Per Hour	Miles Per Hour	0.621

